

aerospace
climate control
electromechanical
filtration
fluid & gas handling
hydraulics
pneumatics
process control
sealing & shielding

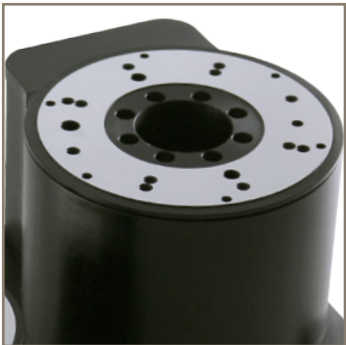

mPR Series Miniature Precision Rotary Stage

High-Precision Rotary Stages



北京润诚时代科技有限公司

自动化事业部

地址：北京市朝阳区汤立路218号C座968室

邮编：100012

电话：010-84450370

传真：010-84450371

网址：www.runcheng.net

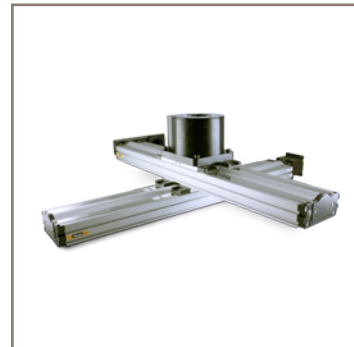

ENGINEERING YOUR SUCCESS.

mPR Series: High-Precision Rotary Stage

Table of Contents

mPR PRODUCT LINE OVERVIEW	3
mPR Design Advantages	4
mPR Application Solutions	5
SPECIFICATIONS	6
mPR080	6
mPR100	7
Speed-Torque Performance	8
Motor Hall and Power Cable Information	9
Stage Wiring Encoder Information	9
Optical Encoder (E1, E2, E3 Option)	9
Sine Cosine Encoder (SC Option)	9
Product Load Information	10
DIMENSIONS	11
mPR80 Dimensions	11
mPR100 Dimensions	12
CONFIGURATIONS	13
mPR80 Multi-Axis Cartesian Robot Configurations	13
mPR100 Multi-Axis Cartesian Robot Configurations	14
mPR SERIES ACCESSORIES	15
ORDERING INFORMATION	16
mPR DRIVE SOLUTIONS	17
Drive/Control Solutions	17
Drive Solutions	17
Full Range of Positioning Solutions from Parker	18
EM Sales Offices	20

The mPR Series

- Compact size
- Self-contained stage includes direct drive motor, high resolution feedback, and high precision rotary bearing
- Easily mounted to existing Parker mSR, MX, and XR product lines
- Very high precision rotary motion

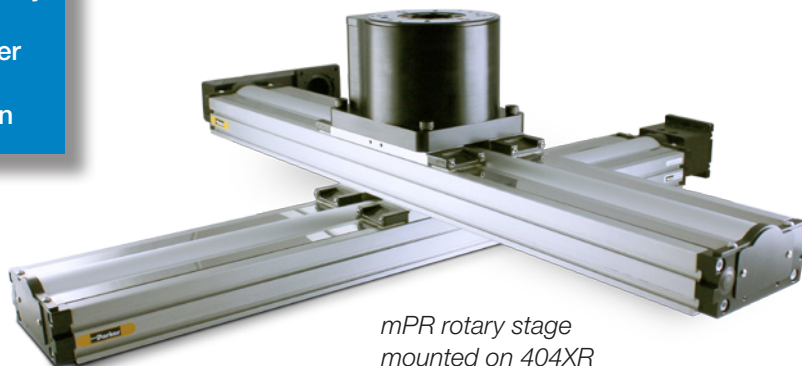

mPR rotary stage mounted on 404XR multi-axis system.

Direct Drive Rotary Stages

Typical Enhancements

- Hall effect sensors for commutation
- Direct mounting pattern for mSR, MX, and XR products
- 3 meter length high-flex cables
- Integrated servo motor
- Ample through hole
- Clean room option available
- 3 digital encoder resolution options, plus a 1 Vp-p analog option
- CE and RoHS compliant as standard



	mPR80	mPR100
Mounts to existing Parker product series:	mSR80	404XR
	mSR100	-
	MX80-L	-

* Note: the mPR stage can be paired with numerous other Parker linear stages. Contact the factory for your exact needs.

The Miniature Precision Rotary (mPR) stage is designed to meet the needs of OEMs and machine builders seeking very high precision in a compact direct drive product.

Two form factors of 80mm and 104mm diameter mount easily on top of small linear motion axes for building complete multi-axis motion systems.

The mPR is lightweight without sacrificing precision and stiffness and delivers excellent torque density.

High angular resolution and precision angular repeatability, combined with high precision runout values, make the mPR a high performer in the field of precision rotary motion control.

The mPR is driven with a direct drive, 3 phase AC servo motor which is integrated directly to the products Aluminum base. The direct drive eliminates mechanical compliance which might exist from gearing or screw driven devices.

As a result the mPR delivers excellent angular dynamic response, and high precision rotary positioning. The combination of all of these features make the mPR the ideal stage for applications in laser processing, electronics manufacturing, semiconductor inspection, and high precision metrology.

For examples of multiaxis systems, visit www.parker.com/emn/mPR.

mPR Design Advantages

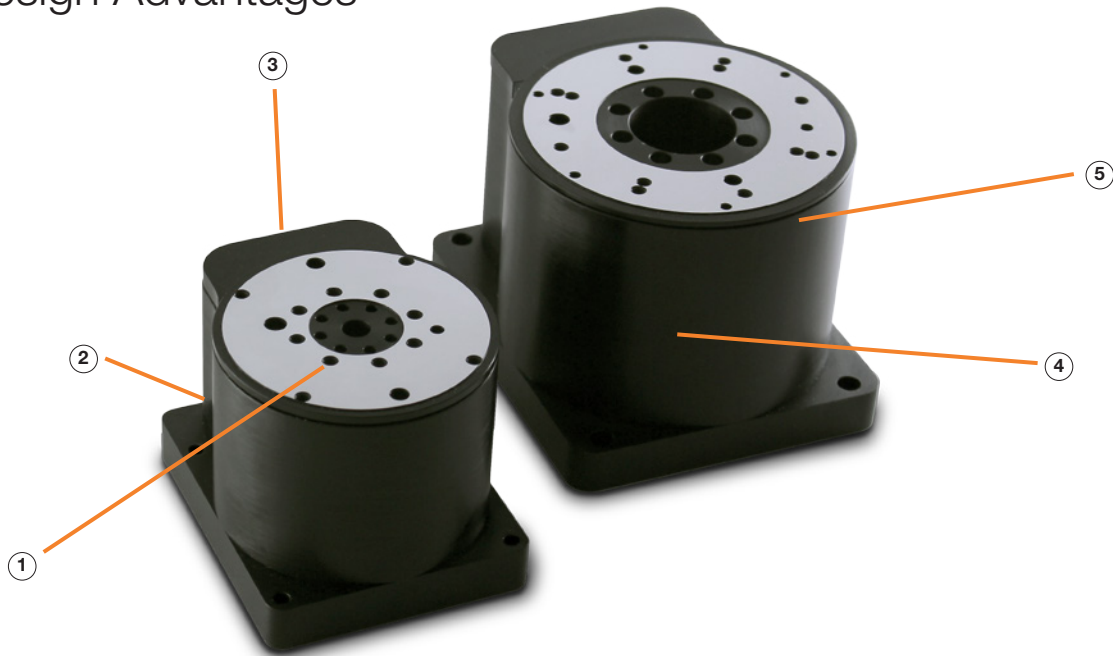

- 1 Tapped Holes and Dowel Pinning**
 The mPR has tapped holes in both the top and base for ease of mounting and dowel pins to ensure repeatable mounting when mounting additional tooling to the stage.
- 2 High Flex Cabling**
 The mPR uses high flex cabling as standard to ensure maximum life of the stage regardless of whether it's integrated into a multi or single axis system.
- 3 Integrated, Optical Linear Encoder**
 The mPR provides maximum versatility with three different optical digital encoder resolutions and an analog sine/cosine option. Easily change resolutions with an external interface, instead of changing the entire head.
- 4 Frameless Kit Motor Direct Drive**
 The frameless kit motor is directly integrated with the drive train to deliver reliable performance in small spaces.
- 5 High Precision Crossed Roller Bearings**
 High performance precision-grade bearings have up to five times the life expectancy of typical ball bearings. These bearings are lubricated for the life of the product to reduce maintenance.

Standard Features

Travel	360 Degree Continuous
Motor	Frameless Direct Drive Motor (will hall Effect Device)
Feedback	Non-Contact Optical Encoder
Scale	20um Pitch Stainless Steel Ring
Resolution	1Vp-p Analog Output (see specifications) Digital Output Options (see specifications)
Sensors	Integrated Home Mark (Encoder Channel C)
Runout	Axial: < 6um available (see specifications) Radial: < 6um available (see specifications)
Bearings	High Precision Crossed Roller Bearings
Encoder Cable	High Flex, 10M Cycle, 3m length
Motor / Hall Cable	Integrated with Motor
Structure	Anodized Aluminum 6064-T6
Environment	Standard Optional: Clean Room
Temperature	0-50 degrees Celsius
Humidity	10-80% Non-Condensing

- 6 Clean Room Tested**
 Limited contact surfaces within the product make the mPR ideal for clean room applications. Higher clean room versions are available for order as custom. Contact the Parker applications engineering department for more details at 1.800.358.9070.

mPR Application Solutions

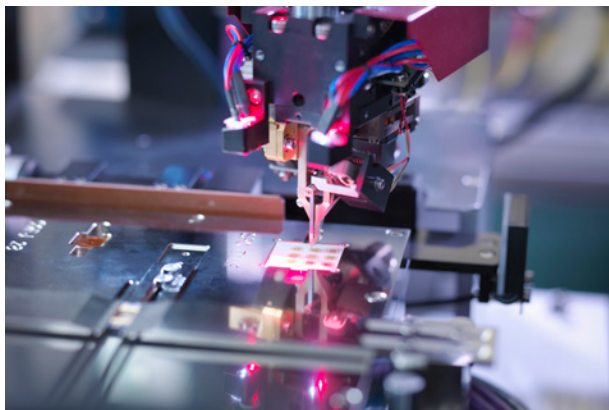

Electronics Manufacturing

The mPR is an ideal theta axis for electronics manufacturing given its combination of tight geometric performance, precision and speed. The combination of precision cross roller bearing, high resolution feedback device, and high performance servo drive make the mPR extremely responsive for high speed pick and place of miniature components for electronics manufacturing. In addition to its geometric and dynamic performance, the mPR is also very robust, as it is designed for 100% duty cycle, and lubricated for the life of the product, requiring no preventative maintenance.

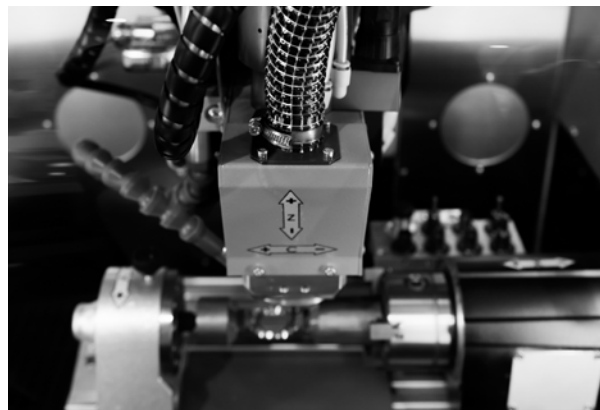

Laser Machining and Laser Processing

The mPR is an excellent rotary axis for laser machining and laser processing applications given its spectacular bearing performance and smooth motion. Regardless if cutting, marking, etching or welding the mPR is an ideal rotary stage for laser processing equipment given the tight integration of slotless rotary servo motor, high resolution feedback and high precision rotary bearing. The combination of all these key design elements in the mPR will make all features in the work piece smooth and precisely positioned.

Direct Drive
Rotary Stages

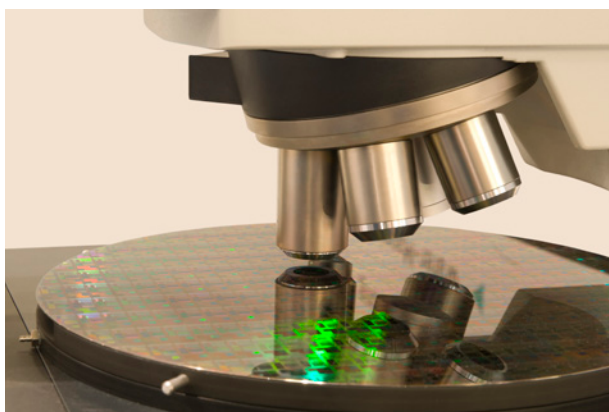

Semiconductor Manufacturing, Handling, and Metrology

The mPR in combination with other Parker precision linear axes (XR, mSR, and MX) make ideal building blocks for applications in semiconductor manufacturing, handling, and metrology. The precision and clean operation make the mPR ideal for applications for skew adjustment of the wafer. Direct mounting to the XR, mSR and MX is also very advantageous when making XY-theta systems.



Precision Metrology

The mPR makes for a spectacular rotary axis for automated metrology equipment. Smooth precise angular motion, and limited runout errors make the mPR an ideal rotary stage for optical metrology equipment measuring miniature parts or features. The compact size and ease of integration make the mPR an ideal rotary compliment to multi axis metrology systems.

SPECIFICATIONS

mPR080

(80 mm diameter profile)

Stage Information

Stage Mass	kg	1.45
Max Load (Axial)	kg	4.0
Max Load (Radial)	kg	4.0
Moving Mass	kg	0.54
Rotating Moment of Inertia	kg*mm ²	320



Motor Information

Stall Current	Arms	1.6
Peak Current	Arms	5.04
Voltage Constant	Vrms/krpm	13.86
Torque Constant	Nm/Arms	0.229
Resistance	Ohms	6.5
Inductance	mH	5.5
Stall Torque Continuous	Nm	0.36
Peak Torque	Nm	0.9
Max Bus Voltage	Vdc	340
Max Winding Temperature	Degree C	125
Winding Thermal Resistance	Deg C / watt	2.36
Magnet Pitch	Deg	120
Motor Thermal Time Constant	minutes	11
Motor Cable Diameter	mm	4.7
Encoder Diameter	mm	4.5
Cable Length	m	3

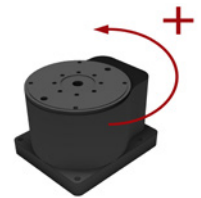
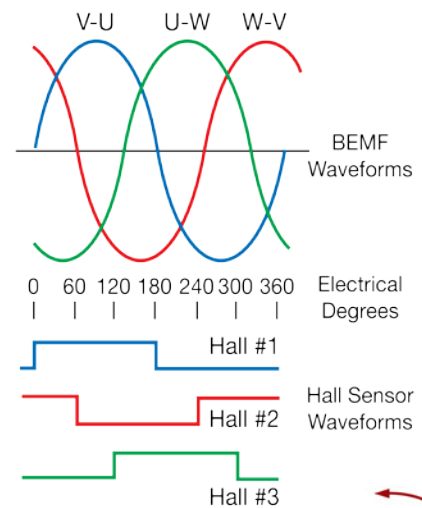

Encoder Dependent Specifications		Encoder Option			
		E1	E2	E3	SC
Travel	Degrees	360	360	360	360
Home Position Location	+/- Degrees	1	1	1	1
Encoder lines Per Revolution	lines / rev	11,840	11,840	11,840	11,840
Encoder Resolution	Arc-Sec	5.4730	0.5473	0.0547	n/a*
Bi-directional Repeatability	+/- Arc-Sec	11	2.5	1.25	*
Axial Runout	µm	6	6	6	6
Radial Runout	µm	6	6	6	6
Wobble	Arc-Sec	15	15	15	15
Max Velocity	RPM	600	100	10	600

* SC encoder resolution is dependent upon drive input resolution.

mPR100 (104 mm diameter profile)

Stage Information

Stage Mass	kg	2.9
Max Load (Axial)	kg	12.0
Max Load (Radial)	kg	12.0
Moving Mass	kg	1.0
Rotating Moment of Inertia	kg*mm ²	1000



Direct Drive Rotary Stages

Motor Information

Stall Current	Arms	3.79
Peak Current	Arms	11.95
Voltage Constant	Vrms/krpm	41.28
Torque Constant	Nm/Arms	0.68
Resistance	Ohms	3.9
Inductance	mH	8.9
Stall Torque Continuous	Nm	2.0
Peak Torque	Nm	6.2
Max Bus Voltage	Vdc	340
Max Winding Temperature	Degree C	125
Winding Thermal Resistance	Deg C / watt	1.02
Magnet Pitch	Deg	60
Motor Thermal Time Constant	minutes	28
Motor Cable Diameter	mm	7.5
Encoder Cable Diameter	mm	4.5
Cable Length	m	3

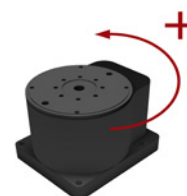
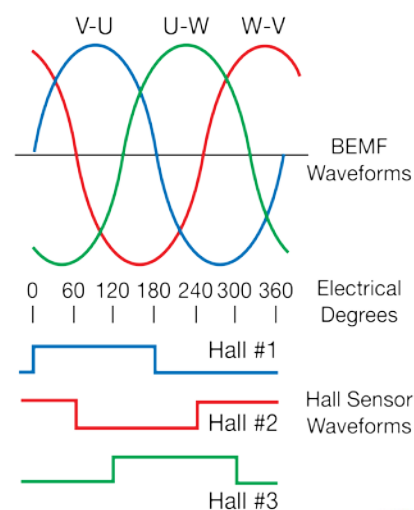

Encoder Dependent Specifications

		Encoder Interpolator			
		E1	E2	E3	SC
Travel	Degrees	360	360	360	360
Home Position Location	+/- Degrees	1	1	1	1
Encoder lines Per Revolution	lines / rev	15,744	15,744	15,744	15,744
Encoder Resolution	Arc-Sec	4.1159	0.4116	0.0412	n/a*
Bi-directional Repeatability	+/- Arc-Sec	10	2	1	*
Axial Runout	µm	6	6	6	6
Radial Runout	µm	6	6	6	6
Wobble	Arc-Sec	12.5	12.5	12.5	12.5
Max Velocity	RPM	600	95	9.5	600

* SC encoder resolution is dependent upon drive input resolution.

Speed-Torque Performance

Parker MotionSizer sizing software available for free download at www.parker.com/emn.

Below are speed-torque performance curves at a variety of different bus voltages supplied to the mPR. To achieve full speed-torque performance of the motor, a bus voltage of 170–340 volts is required. ***Note: Speed is limited by encoder resolution. See specifications sheet for limits.**

mPR80

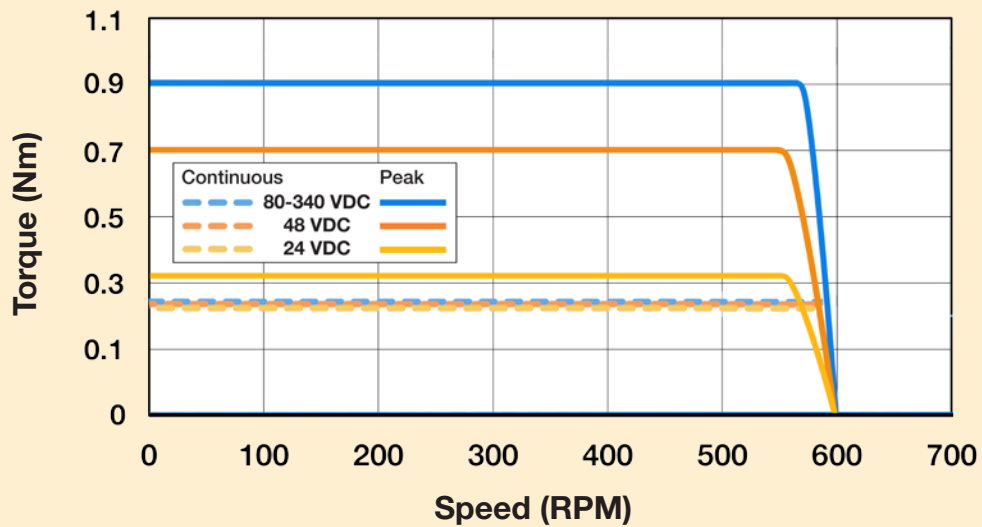

mPR100

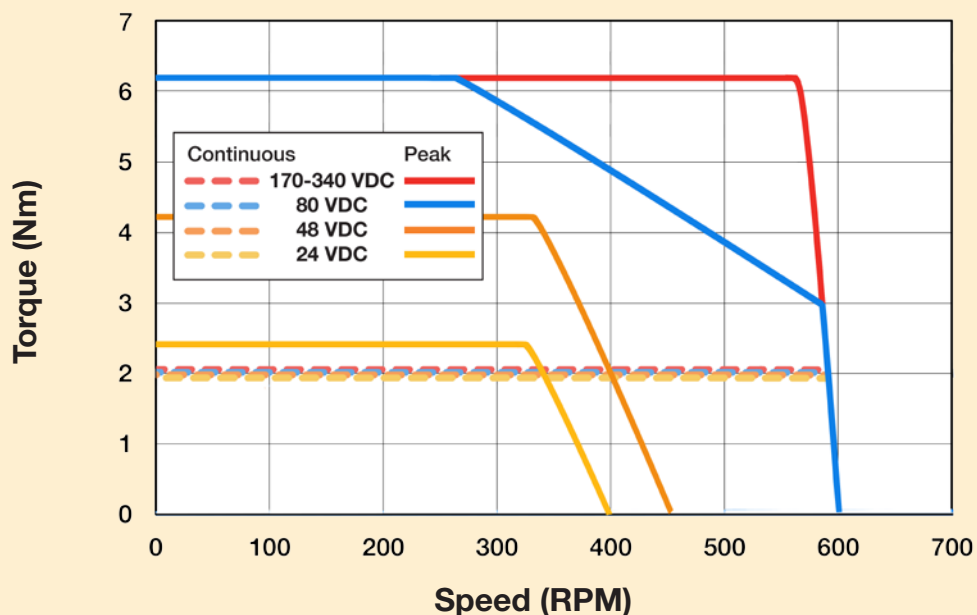

Motor Hall and Power Cable Information

Male 9 Pin D-Sub

Color	Function	Pin Number
Black	Hall Power	5
White	Hall Ground	6
Yellow	H1	7
Blue	H2	8
Green	H3	9

Motor Leads

Color	Function
Red	U
Brown	V
Orange	W
Green/Yellow	Ground

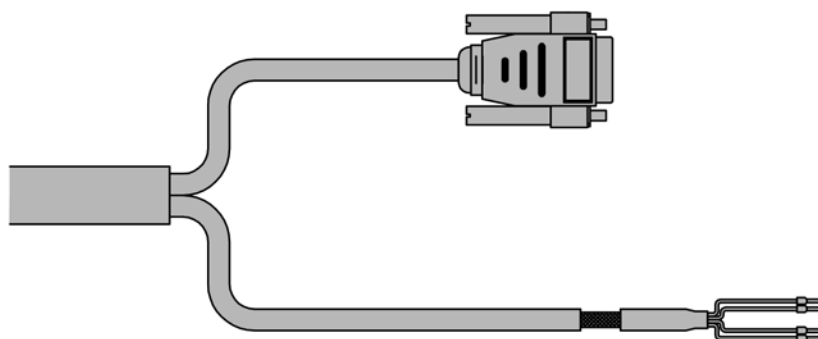

Stage Wiring Encoder Information

Optical Encoder (E1, E2, E3 Option)

Function	Signal	Pin #
Power	5 Volts DC	8
	Ground	2, 9
Incremental Signals	A+	14
	A-	6
	B+	13
	B-	5
Reference Mark	Z+	12
	Z-	4
Limits	Positive Limit	11
	Negative Limit	10
Setup	(Used in installation)	1
Error Output	NPN	3

Sine Cosine Encoder (SC Option)

Function	Signal	Pin #
Power	5 Volts DC	4, 5
	0 Volts DC	12, 13
Incremental Signals	Cosine +	9
	Cosine -	1
	Sine +	10
	Sine -	2
Reference Mark	Z+	3
	Z-	11
Limits	Positive Limit	7
	Negative Limit	8
Setup	(Used in installation)	6
Remote Calibration	NPN	14

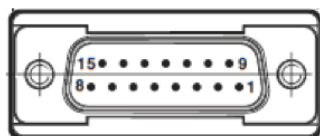

Product Load Information

Moment Loading

Below are two plots indicating the maximum allowable moment arms at a given payload to ensure product life of 1 billion revolutions.

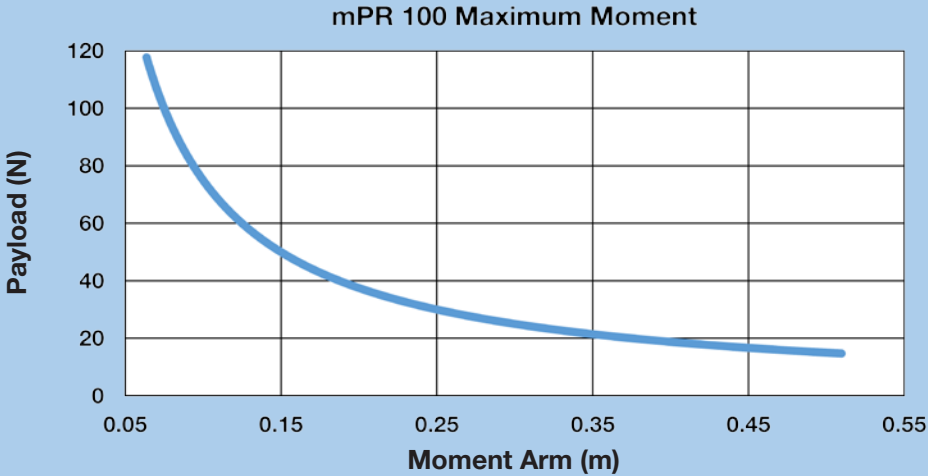
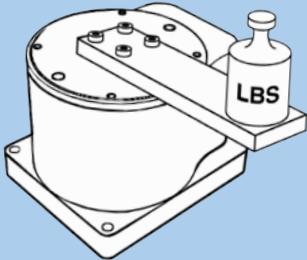
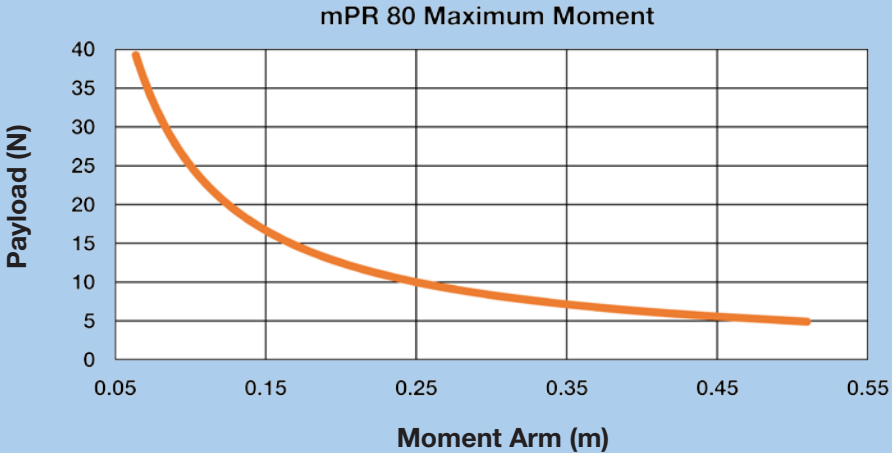

DIMENSIONS

mPR80 Dimensions

Download 2D & 3D files from
www.parker.com/emn/mPR



Dimensions (mm)

Direct Drive
 Rotary Stages

Top view (mPR80)

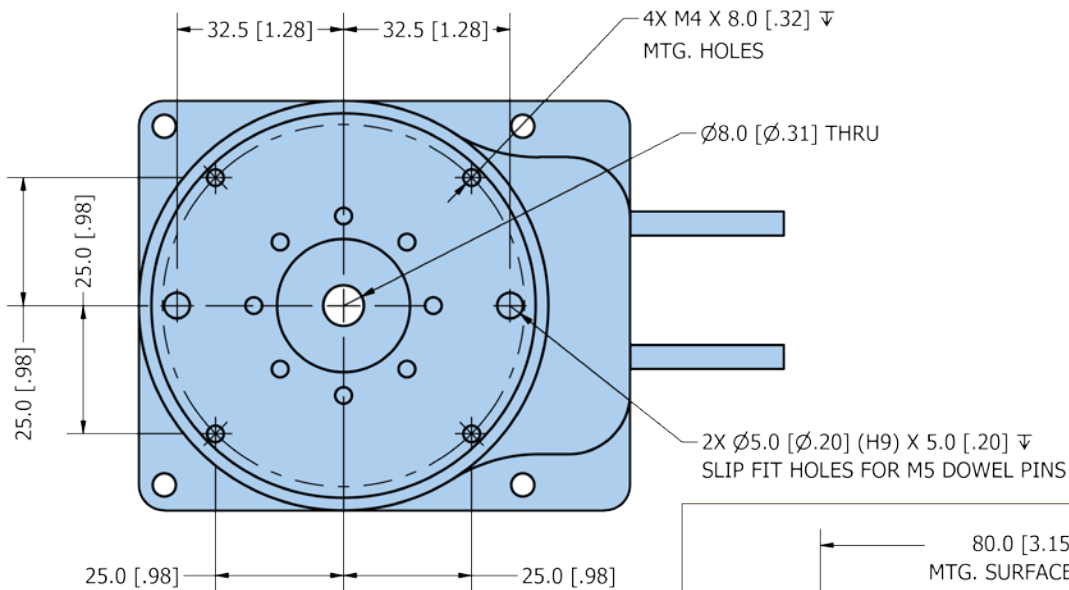

Bottom view (mPR80)

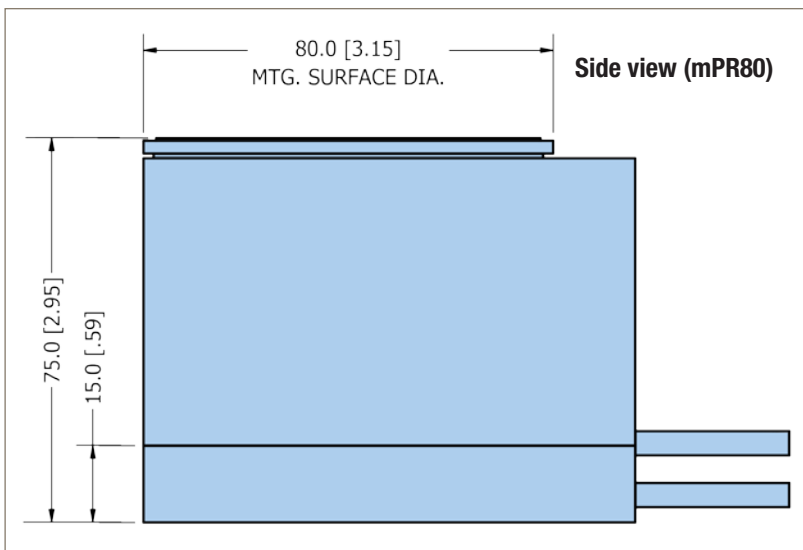
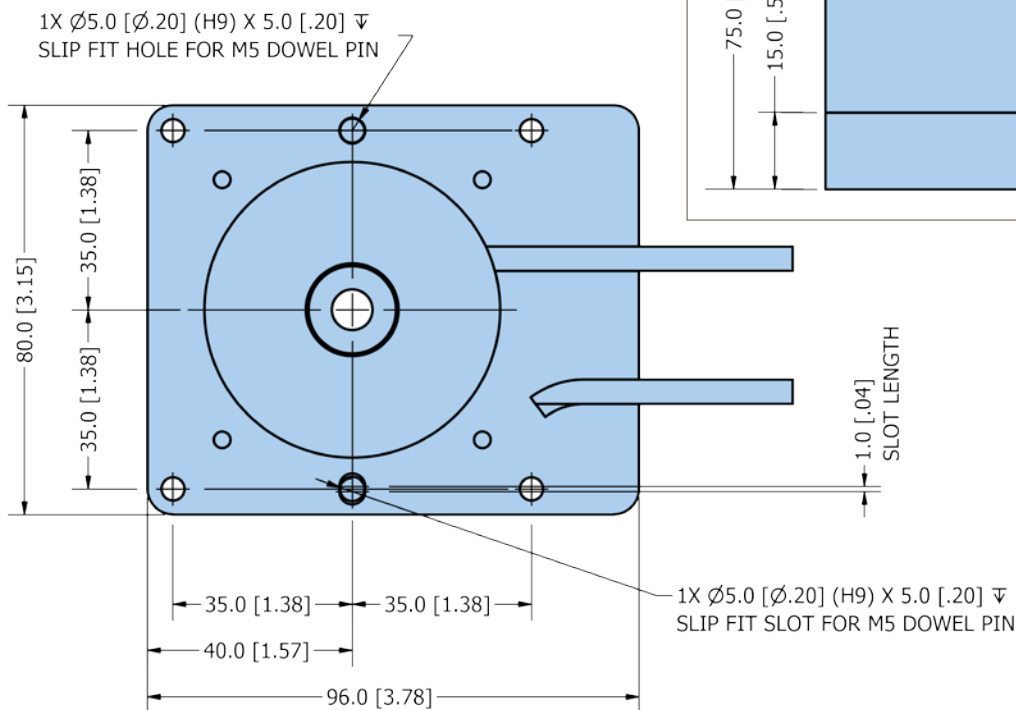

mPR100 Dimensions

Download 2D & 3D files from www.parker.com/emn/mPR



Top view (mPR100)

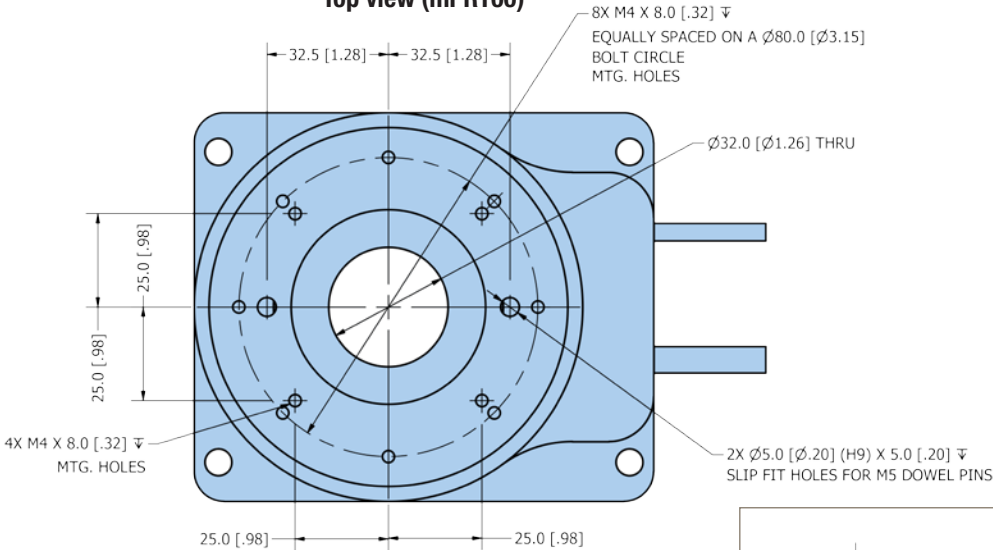

Side view (mPR100)

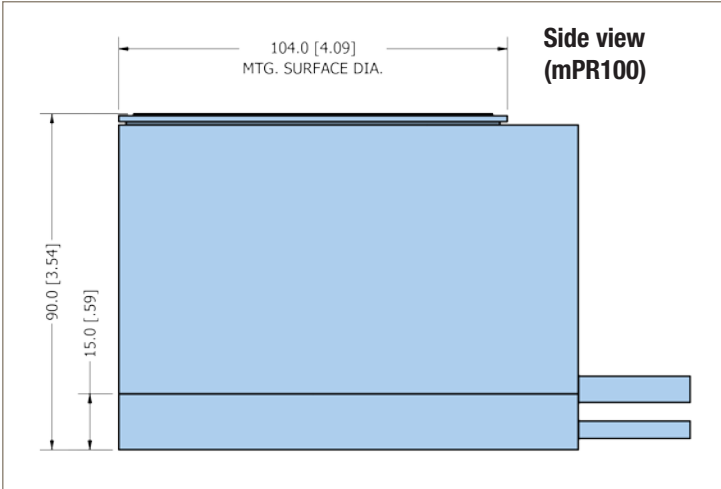

Bottom view (mPR100)

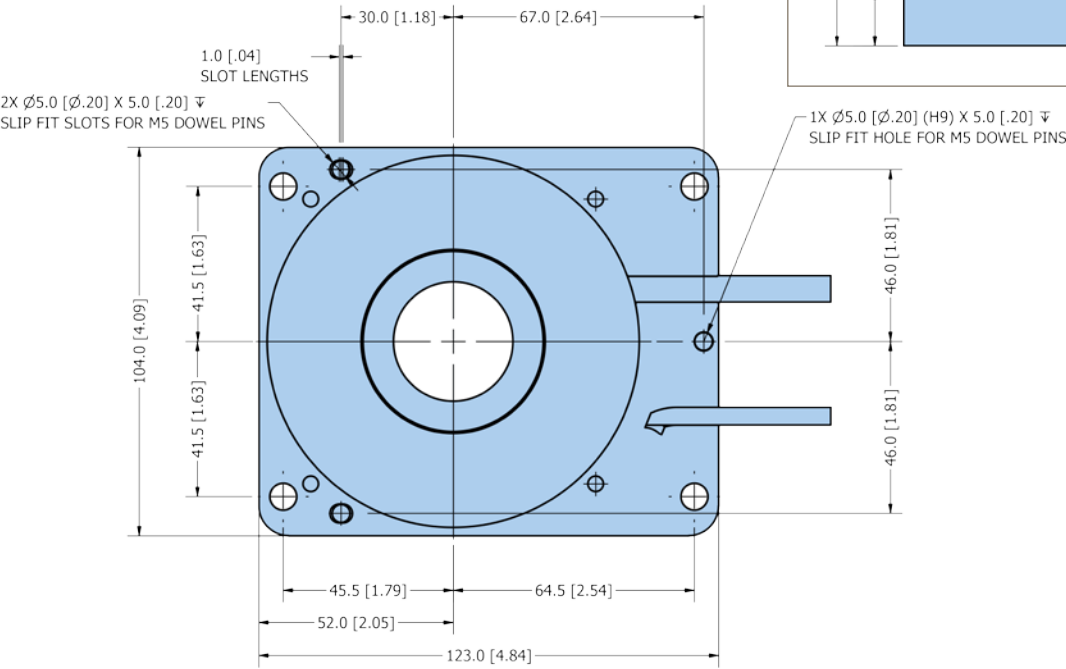

CONFIGURATIONS

mPR80 Multi-Axis Cartesian Robot Configurations

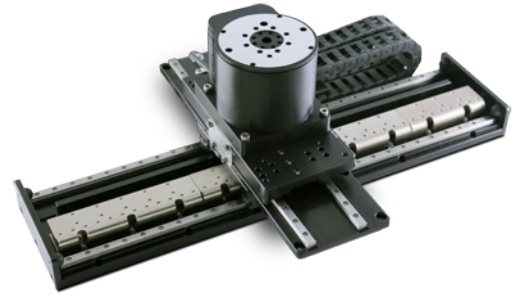

Direct Drive
Rotary Stages

Top

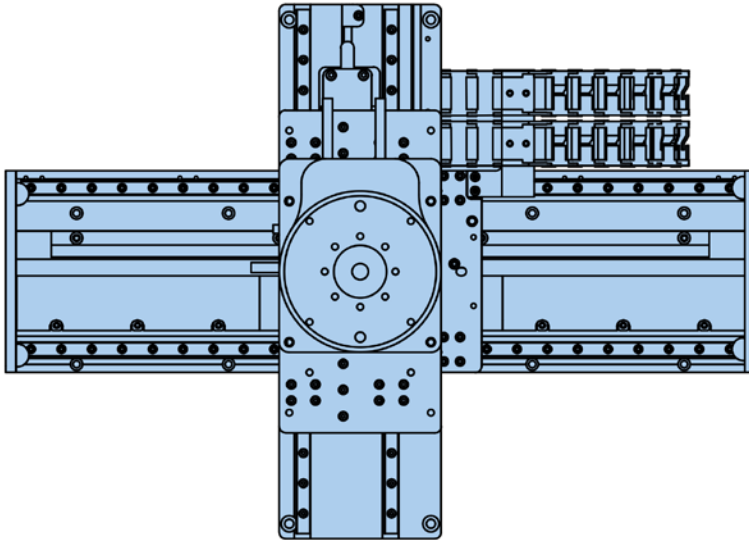

Side

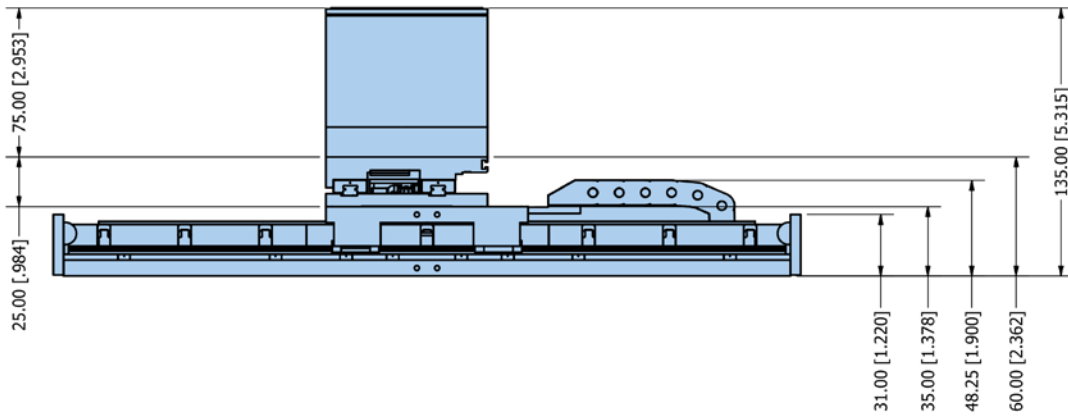

Front

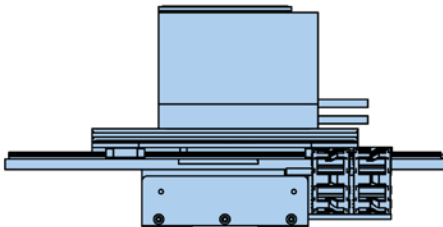

Isometric

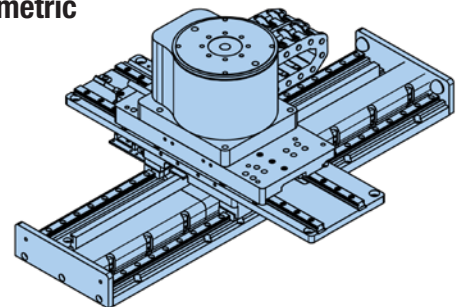

mPR100 Multi-Axis Cartesian Robot Configurations

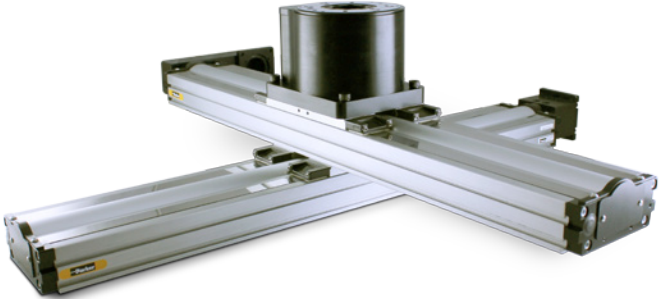

Top

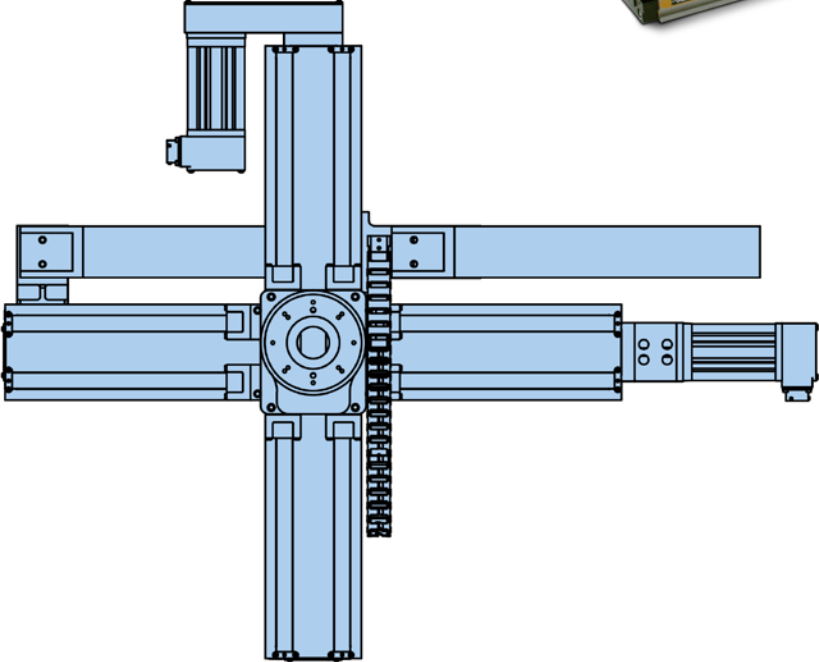

Side

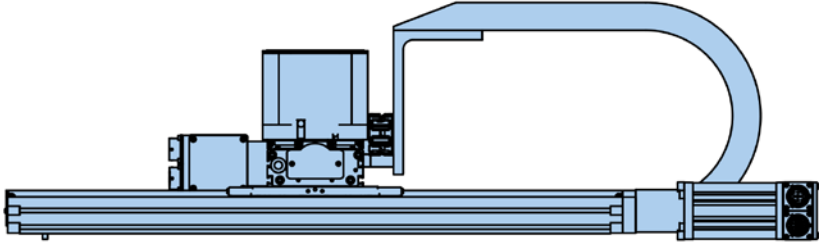

Front

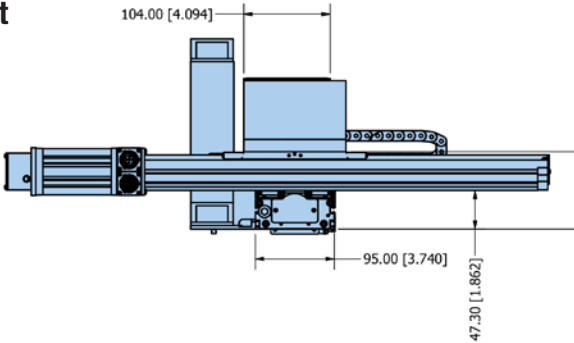

Isometric

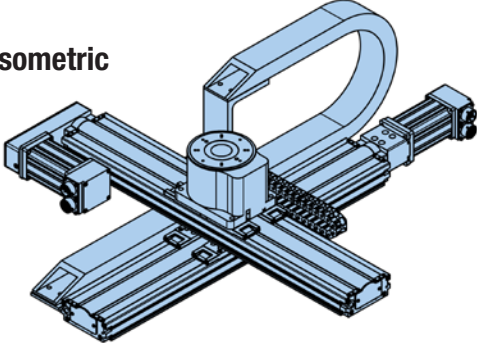

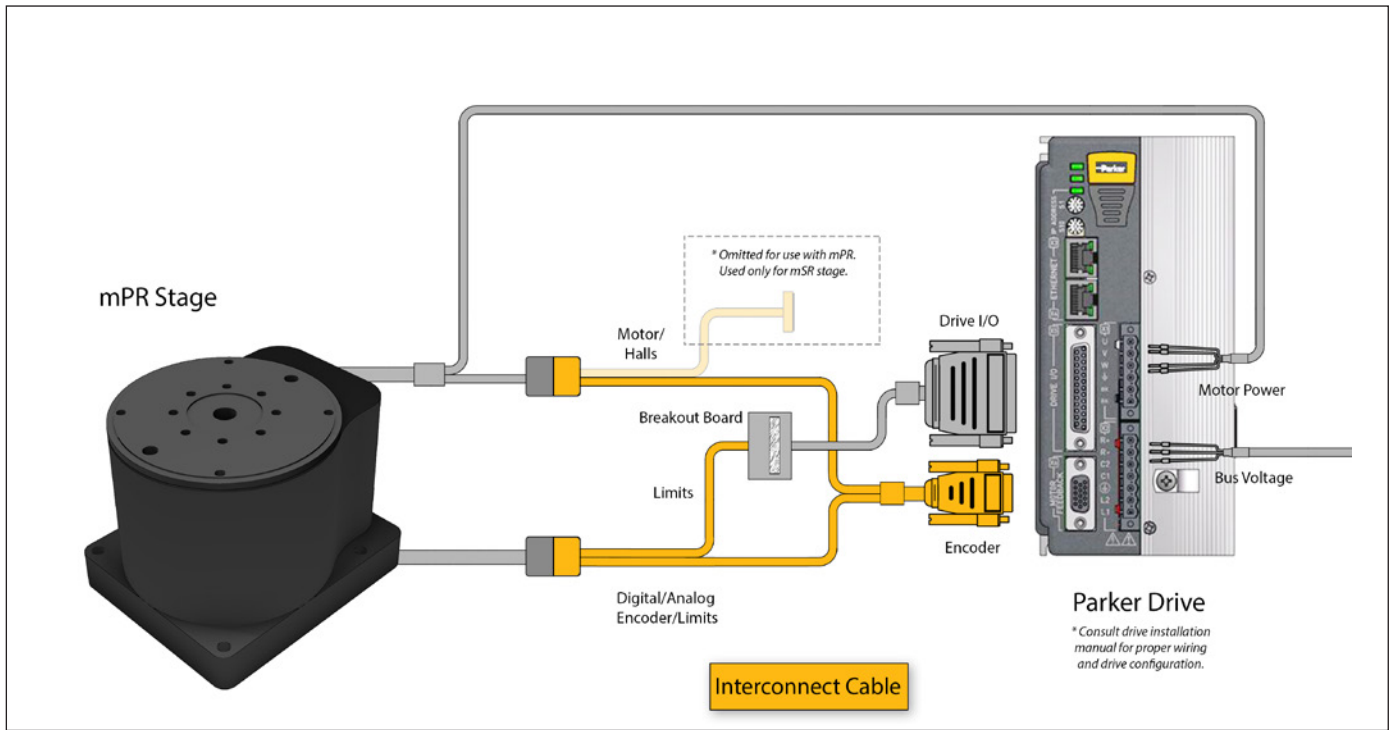

Parker Drives and Cable Accessory Part Numbers

Encoder Type	Drive	Cable Interconnect Part Number
Digital	IPA	006-2690-01
Analog	IPA	006-2692-01
Digital	P Series	006-2691-01
Digital/Analog	Motor Power and Hall Flying Lead	006-2678-01
Digital	Digital Encoder Flying Lead	006-2679-01
Analog	Analog Encoder Flying Lead	006-2680-01

ORDERING INFORMATION

Fill in an order code from each of the numbered fields to create a complete model order code.

① ② ③ ④ ⑤ ⑥ ⑦ ⑧

Order Example:

mPR 080 D A E2 H 3 N

- ① **Series**
mPR
- ② **Size**
080 80mm
100 104mm
- ③ **Drive**
D Direct
- ④ **Motor Option**
A Standard Option
- ⑤ **Encoder Resolution**
E1 5.47 Arc-Sec
E2 0.547 Arc-Sec
E3 0.0547 Arc-Sec
SC Analog Sine / Cosine
- ⑥ **Home**
H H
- ⑦ **Cable Option**
3 3 meter high-flex
- ⑧ **Clean Room Option**
N Standard Class 1000
* Consult factory for higher cleanroom options

mPR Drive Solutions

Drive/Control Solutions



The Intelligent Parker Amplifier, or IPA, is a versatile servo drive/controller based on the ACR control platform.

The IPA provides a dual port Ethernet interface which gives the machine builder the flexibility needed to create cost effective motion control solutions.

The IPA operates as a fully programmable stand-alone motion controller with on-board I/O and virtual axis capability or can be integrated into a PLC or PC-based machine control solution.

Software tools are included to optimize motion performance and efficiently monitor and manage the application.

EtherNet/IP gives IPA users a popular connectivity option to PLCs for easy integration of servo motion in larger machine control application. The IPA is an EtherNet/IP adapter device supporting both I/O and Explicit Messaging. Add-On Instructions are available for seamless integration with Logix controllers.

Direct Drive
Rotary Stages

Drive Solutions



P Series Drive

P Series - DC version

The P-Series drives operate with a variety of machine control architectures, and offer sophisticated servo functionality. Accurate and easy to use inertia detection leads to fast set-up of tuning parameters and minimal settling time.

Advanced filtering and vibration suppression features can be used to increase throughput and improve positioning performance.

For high speed, real-time network applications, the P-Series is available with, EtherCAT, the fastest growing, most flexible industrial Ethernet protocol. Ideal for use with the Parker Automation Controller, the P-Series also follows the open standards for EtherCAT.

The Pulse version can be configured for step and direction control input and includes analog inputs for torque or velocity control. Select Indexer mode to create up to 64 position table entries triggered via inputs or over a RS422 interface.

Full Range of Positioning Solutions from Parker

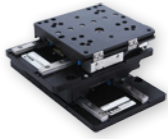

mSR Series

The mSR series positioner is the most accurate standard positioner ever offered by Parker, delivering submicron level precision in two form factors. The mSR offers OEMs high precision motion in an ultra small package.



MX Series

Designed to meet decreasing size requirements, the MX is one of the smallest linear servo motor and screw-driven positioners in the industry. Loaded with high performance features, the MX redefines "high-throughput automation" for 24/7 production demands.

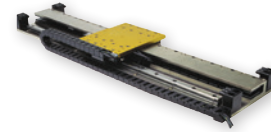

T Series

Delivering high performance with economy, Trilogy positioners offer design flexibility that accommodates customization. Trilogy uses ironless linear motor technology in a pre-engineered, easily integrated, ready-to-run package.



XR Series

The award-winning XR Series is globally recognized for consistent accuracy, reliable performance, high strength, and unmatched versatility. The XR family offers an unrivaled array of features and modularity that easily match any application.



LXR Series

The 400LXR Series linear servo motor tables offer high acceleration, velocity, and precision with quick settling for superior throughput. The 400LXR Series can solve most high-performance applications.

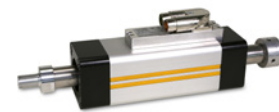

ETT Series

The ETT offers a unique solution for high speed, high acceleration, and dynamic positioning capabilities. Linear motor technology delivers enhanced performance, smaller overall size, and reduced system cost and maintenance.



XE Series

Highly accurate and cost-effective, the XE combines versatility and rugged steel body construction for significant force-per-dollar value. The economical XE easily integrates into multi-axis designs.

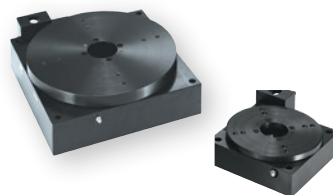

RT Series

RT Series rotary tables are designed for precise motor-driven rotary positioning and indexing. The rugged main support bearing and precision worm gear assembly deliver smooth flat motion with no backlash.



PM DD Series

P Series direct-drive rotary motors are high performance integrated positioning systems. The combination of high torque, zero backlash and precision bearing structure results in fast settling time and outstanding accuracy.

Offer of Sale

The items described in this document and other documents or descriptions provided by Parker, its subsidiaries and its authorized distributors are hereby offered for sale at prices to be established by Parker Hannifin Corporation, its subsidiaries and its authorized distributors. This offer and its acceptance by any customer ("Buyer") shall be governed by all of the following Terms and Conditions. Buyer's order for any such item, when communicated to Parker, its subsidiary or an authorized distributor ("Seller") verbally or in writing, shall constitute acceptance of this offer.

1. **Terms and Conditions of Sale:** All descriptions, quotations, proposals, offers, acknowledgments, acceptances and sales of Seller's products are subject to and shall be governed exclusively by the terms and conditions stated herein. Buyer's acceptance of any offer to sell is limited to these terms and conditions. Any terms or conditions in addition to, or inconsistent with those stated herein, proposed by Buyer in any acceptance of an offer by Seller, are hereby objected to. No such additional, different or inconsistent terms and conditions shall become part of the contract between, Buyer and Seller unless expressly accepted in writing by Seller. Seller's acceptance of any offer to purchase by Buyer is expressly conditional upon Buyer's assent to all the terms and conditions stated herein, including any terms in addition to, or inconsistent with those contained in Buyer's offer. Acceptance of Seller's products shall in all events constitute such assent.

2. **Payment:** Payment shall be made by Buyer net 30 days from the date of delivery of the items purchased hereunder. Amounts not timely paid shall bear interest at the maximum rate permitted by law for each month or portion thereof that the Buyer is late in making payment. Any claims by Buyer for omissions or shortages in a shipment shall be waived unless Seller receives notice thereof within 30 days after Buyer's receipt of the shipment.

3. **Delivery:** Unless otherwise provided on the face hereof, delivery shall be made F.O.B. Seller's plant. Regardless of the method of delivery, however, risk of loss shall pass to Buyer upon Seller's delivery to a carrier. Any delivery dates shown are approximate only and Seller shall have no liability for any delays in delivery.

4. **Warranty:** Seller warrants that the items sold hereunder shall be free from defects in material or workmanship for a period of 12 months from date of shipment from Parker. THIS WARRANTY COMPRISES THE SOLE AND ENTIRE WARRANTY PERTAINING TO ITEMS PROVIDED HEREUNDER. SELLER MAKES NO OTHER WARRANTY, GUARANTEE, OR REPRESENTATION OF ANY KIND WHATSOEVER. ALL OTHER WARRANTIES, INCLUDING BUT NOT LIMITED TO, MERCHANTABILITY AND FITNESS FOR PURPOSE, WHETHER EXPRESS, IMPLIED, OR ARISING BY OPERATION OF LAW, TRADE USAGE, OR COURSE OF DEALING ARE HEREBY DISCLAIMED. NOTWITHSTANDING THE FOREGOING, THERE ARE NO WARRANTIES WHATSOEVER ON ITEMS BUILT OR ACQUIRED WHOLLY OR PARTIALLY, TO BUYER'S DESIGNS OR SPECIFICATIONS.

5. **Limitation of Remedy:** SELLER'S LIABILITY ARISING FROM OR IN ANY WAY CONNECTED WITH THE ITEMS SOLD OR THIS CONTRACT SHALL BE LIMITED EXCLUSIVELY TO REPAIR OR REPLACEMENT OF THE ITEMS SOLD OR REFUND OF THE PURCHASE PRICE PAID BY BUYER, AT SELLER'S SOLE OPTION. IN NO EVENT SHALL SELLER BE LIABLE FOR ANY INCIDENTAL, CONSEQUENTIAL OR SPECIAL DAMAGES OF ANY KIND OR NATURE WHATSOEVER, INCLUDING BUT NOT LIMITED TO LOST PROFITS ARISING FROM OR IN ANY WAY CONNECTED WITH THIS AGREEMENT OR ITEMS SOLD HEREUNDER, WHETHER ALLEGED TO ARISE FROM BREACH OF CONTRACT, EXPRESS OR IMPLIED WARRANTY, OR IN TORT, INCLUDING WITHOUT LIMITATION, NEGLIGENCE, FAILURE TO WARN OR STRICT LIABILITY.

6. **Changes, Reschedules and Cancellations:** Buyers may request to modify the designs or specifications for the items sold hereunder as well as the quantities and delivery dates thereof, or may request to cancel all or part of this order, however, no such requested modification or cancellation shall become part of the contract between Buyer and Seller unless accepted by Seller in a written amendment to this Agreement. Acceptance of any such requested modification or cancellation shall be at Seller's discretion, and shall be upon such terms and conditions as Seller may require.

7. **Special Tooling:** A tooling charge may be imposed for any special tooling, including without limitation, dies, fixtures, molds and patterns, acquired to manufacture items sold pursuant to this contract. Such special tooling shall be and remain Seller's property notwithstanding payment of any charges by Buyer. In no event will Buyer acquire any interest in apparatus belonging to Seller which is utilized in the manufacture of the items sold hereunder, even if such apparatus has been specially converted or adapted for such manufacture

and notwithstanding any charges paid by Buyer. Unless otherwise agreed, Seller shall have the right to alter, discard or otherwise dispose of any special tooling or other property in its sole discretion at any time.

8. **Buyer's Property:** Any designs, tools, patterns, materials, drawings confidential information or equipment furnished by Buyer, or any other items which become Buyer's property, may be considered obsolete and may be destroyed by Seller after two (2) consecutive years have elapsed without Buyer placing an order for the items which are manufactured using such property. Seller shall not be responsible for any loss or damage to such property while it is in Seller's possession or control.

9. **Taxes:** Unless otherwise indicated on the face hereof, all prices and charges are exclusive of excise, sales, use, property, occupational or like taxes which may be imposed by any taxing authority upon the manufacture, sale or delivery of the items sold hereunder. If any such taxes must be paid by Seller or if Seller is liable for the collection of such tax, the amount thereof shall be in addition to the amounts for the items sold. Buyer agrees to pay all such taxes or to reimburse Seller therefore upon receipt of its invoice. If Buyer claims exemption from any sales, use or other tax imposed by any taxing authority, Buyer shall save Seller harmless from and against any such tax, together with any interest or penalties thereon which may be assessed if the items are held to be taxable.

10. **Indemnity For Infringement of Intellectual Property Rights:** Seller shall have no liability for infringement of any patents, trademarks, copyrights, trade dress, trade secrets or similar rights except as provided in this Part 10. Seller will defend and indemnify Buyer against allegations of infringement of U.S. patents, U.S. trademarks, copyrights, trade dress and trade secrets (hereinafter 'Intellectual Property Rights'). Seller will defend at its expense and will pay the cost of any settlement or damages awarded in an action brought against Buyer based on an allegation that an item sold pursuant to this contract infringes the Intellectual Property Rights of a third party. Seller's obligation to defend and indemnify Buyer is contingent on Buyer notifying Seller within ten (10) days after Buyer becomes aware of such allegations of infringement, and Seller having sole control over the defense of any allegations or actions including all negotiations for settlement or compromise. If an item sold hereunder is subject to a claim that it infringes the Intellectual Property Rights of a third party, Seller may, at its sole expense and option, procure for Buyer the right to continue using said item, replace or modify said item so as to make it non infringing, or offer to accept return of said item and return the purchase price less a reasonable allowance for depreciation. Notwithstanding the foregoing, Seller shall have no liability for claims of infringement based on information provided by Buyer, or directed to items delivered hereunder for which the designs are specified in whole or part by Buyer, or infringements resulting from the modification, combination or use in a system of any item sold hereunder. The foregoing provisions of this Part 10 shall constitute Seller's sole and exclusive liability and Buyer's sole and exclusive remedy for infringement of Intellectual Property Right. If a claim is based on information provided by Buyer or if the design for an item delivered hereunder is specified in whole or in part by Buyer, Buyer shall defend and indemnify Seller for all costs, expenses or judgments resulting from any claim that such item infringes any patent, trademark, copyright, trade dress, trade secret or any similar right.

11. **Force Majeure:** Seller does not assume the risk of and shall not be liable for delay or failure to perform any of Seller's obligations by reason of circumstances beyond the reasonable control of Seller (hereinafter 'Events of Force Majeure'). Events of Force Majeure shall include without limitation, accidents, acts of God, strikes or labor disputes, acts, laws, rules or regulations of any government or government agency, fires, floods, delays or failures in delivery of carriers or suppliers, shortages of materials and any other cause beyond Seller's control.

12. **Entire Agreement/Governing Law:** The terms and conditions set forth herein, together with any amendments, modifications and any different terms or conditions expressly accepted by Seller in writing, shall constitute the entire Agreement concerning the items sold, and there are no oral or other representations or agreements which pertain thereto. This Agreement shall be governed in all respects by the law of the State of Ohio. No actions arising out of the sale of the items sold hereunder of this Agreement may be brought by either party more than two (2) years after the cause of action accrues.

WARNING

FAILURE OR IMPROPER SELECTION OR IMPROPER USE OF THE PRODUCTS AND/OR SYSTEMS DESCRIBED HEREIN OR RELATED ITEMS CAN CAUSE DEATH, PERSONAL INJURY AND PROPERTY DAMAGE.

This document and other information from Parker Hannifin Corporation, its subsidiaries and authorized distributors provide product and/or system options for further investigation by users having technical expertise. It is important that you analyze all aspects of your application and review the information concerning the product or system in the current product catalog. Due to the variety of operating conditions and applications for these products or systems, the user, through its own analysis and testing, is solely responsible for making the final selection of the products and systems and assuring that all performance, safety and warning requirements of the application are met.

The products described herein, including without limitation, product features, specifications, designs, availability and pricing, are subject to change by Parker Hannifin Corporation and its subsidiaries at any time without notice.



mPR Series:
Made in the USA



北京润诚时代科技有限公司

自动化事业部

地址：北京市朝阳区汤立路218号C座968室

邮编：100012

电话：010-84450370

传真：010-84450371

网址：www.runcheng.net

