

88-032356-01 Rev C



aerospace
 climate control
 electromechanical
 filtration
 fluid & gas handling
 hydraulics
 pneumatics
 process control
 sealing & shielding



Parker战略合作伙伴



北京润诚时代科技有限公司

自动化事业部

地址：北京市朝阳区汤立路218号C座968室

邮编：100012

电话：010-84450370

传真：010-84450371

网址：www.runcheng.net



Electric and Hybrid Vehicle

Accessory, Power Generation & Traction Motor Solutions

ENGINEERING YOUR SUCCESS.

GVM Series Motors

Breakthrough Performance

The GVM (Global Vehicle Motor) is Parker's PMAC offering for electric and hybrid electric powertrain motors, and electro-hydraulic actuation.

The GVM utilizes highly engineered magnetics to achieve efficiencies in peak regions not obtainable in other designs. It uses a new patent-pending advanced cooling system that has minimal impact on the size and weight of the motor. The scalability of the GVM allows the widest performance range available.

Tested to the demanding heavy duty vehicle grade standards of SAE J1455 the GVM can handle the toughest jobs making it a powerful choice for both on and off-road vehicles.

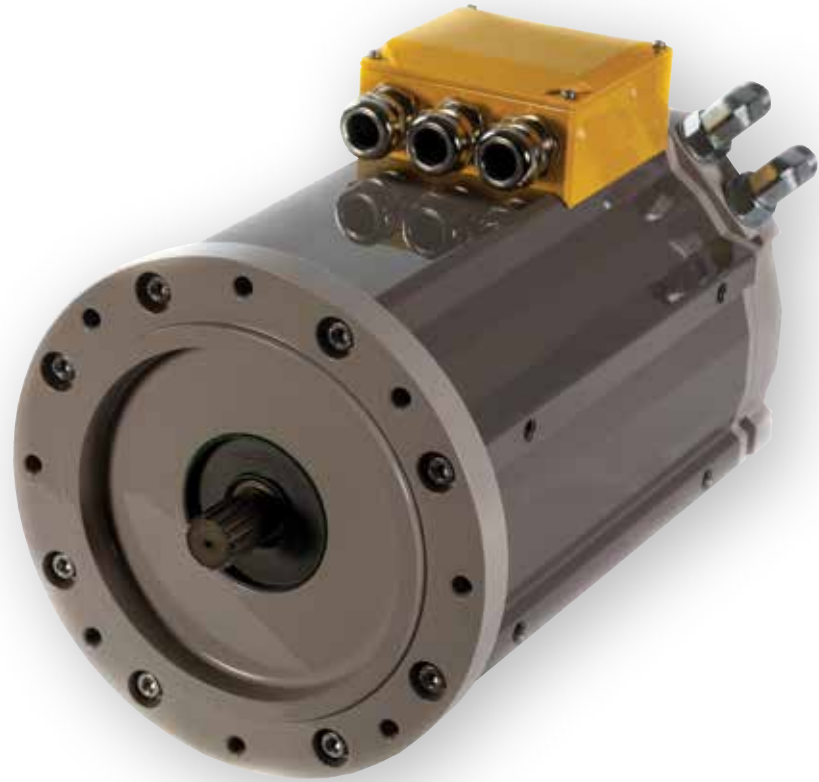

Features

- **Peak power density up to 4.2 kW/kg**
- **Continuous power density up to 2.3 kW/kg**
- **Operating voltages available from 24 to 800 VDC**
- **Samarium Cobalt (SmCo) magnets allow high temperature operation and removes demagnetization failure mode**
- **Highly efficient design reduces thermal dissipation requirements, lowering overall cooling system costs**
- **Very low torque ripple - even at peak current**
- **Low rotor inertia for high dynamic responsiveness**
- **Can provide up to 20% more range for a given battery pack**
- **Ultra-thin stator laminations with reduced slots virtually eliminates eddy currents**
- **Patent pending cooling configuration yields very high cooling effectiveness regardless of motor length**
- **Meets SAE J1455 heavy-duty vehicle environmental standards**

Motor Performance Definitions

GVM Series motors are designed to meet the power requirements in a wide variety of vehicle applications. The GVM has the ability to operate at different bus voltages, without loss of power.

- Two frame sizes
- Multiple operating voltages
- Numerous rotor lengths
- Multiple winding configurations per length

= Hundreds of unique motor size and performance configurations

By selecting the appropriate voltage, rotor length and winding variation, the following parameters can be refined to match the vehicle's specific performance requirements:

- Peak torque
- Base speed
- Peak power
- Stall torque
- Rated torque
- Rated speed
- Rated power
- Maximum speed

The performance data on the following pages of this catalog provide speed, torque and power performance at various specified VDC (as defined by the illustrations and chart example shown below).

To Estimate Performances at Other Voltages:

- 1) Calculate Voltage Ratio $V_{rat} = (V_{new}/350VDC)$ or $V_{rat} = (V_{new}/650VDC)$
- 2) Multiply speed and power values by ratio (#2, #3, #6, #7, #8)
- 3) Do not change torque values
- 4) Overlay new values for #1 - #8 onto definitions chart for rough performance curve

Please contact your Parker Representative for assistance.

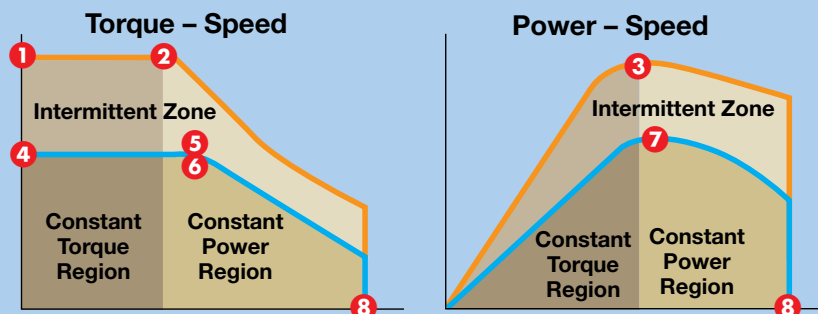

Parameter	GVM210-050A	GVM210-05
1 Peak Torque (Nm)	76	77
2 Base Speed (RPM)	843	1,374
3 Peak Power (kW)	8	13
4 Stall Torque Continuous (Nm)	42	41
5 Rated Torque (Nm)	36	36
6 Rated Speed (RPM)	1,361	2,245
7 Rated Shaft Output Power (kW)	5	8
8 Max Continuous Speed* (RPM)	1,966	3,000
Stall Current Peak (Amp RMS)	29	
Stall Current Continuous (Amp RMS)	14	
Coolant Temperature (°C)	60	
Max Winding Temperature (°C)	180	
Winding Temp at Rating (°C)	140	

Winding Configuration Code
Rotor Length
Frame Size

* Maximum continuous speed is reached when B_{emf} exceeds bus voltage. Maximum continuous mechanical speed is 8000 rpm, and maximum intermittent speed is 10,500 rpm.

GVM Series Motors

GVM142 Accessory Motors & Generators



Model	GVM142-050	GVM142-075	GVM142-100
Page	6 – 11	12 – 17	18 – 23
Max. Torque Output Range (Nm)			
Peak	32.0	50.2	67.4
Continuous	17.2	26.8	36.0
Winding Choices Available			
48 VDC	12	11	11
96 VDC	10	11	11
350 VDC	8	9	9
Rated Speed¹ (RPM)			
48 VDC	1669 – 10,318	1449 – 6879	1033 – 5081
96 VDC	1729 – 11,009	1438 – 10,030	1043 – 8006
350 VDC	1699 – 12,472	1747 – 12,671	1267 – 9841
Peak Power¹ (kW)			
48 VDC	3.9 – 27.0	5.0 – 27.0	4.6 – 28.0
96 VDC	4.0 – 31.0	5.0 – 43.0	4.7 – 43.0
350 VDC	3.8 – 36.0	6.3 – 56.0	6.0 – 57.0
Rated Shaft Output Power¹ (kW)			
48 VDC	2.6 – 14.0	3.4 – 14.0	3.3 – 13.9
96 VDC	2.6 – 16.0	3.4 – 23.0	3.3 – 24.0
350 VDC	2.5 – 17.0	4.1 – 27.0	4.0 – 30.0

¹ Rated value dependant on winding selection

² Maximum peak power shows performance of the motor at base speeds of ~7500 rpm. Contact factory for details

GVM210 Traction Motors & Generators



Model	GVM210-050	GVM210-100	GVM210-150
Page	28 – 31	32 – 35	36 – 39
Max. Torque Output Range (Nm)			
Peak	79	168	258
Continuous	43	79	122
Winding Choices Available			
350 VDC	8	11	12
650 VDC	5	7	10
Base Speed ¹ (RPM)			
350 VDC	843 – 6166	1303 – 5902	1207 – 4933
650 VDC	1685 – 7575	1246 – 5549	1146 – 5990
Peak Power ¹ (kW)			
350 VDC	8 – 58	26 – 117	36 – 150
650 VDC	16 – 63	25 – 110	34 – 179
Rated Shaft Output Power ¹ (kW)			
350 VDC	5 – 32	18 – 65	26 – 90
650 VDC	10 – 31	17 – 63	25 – 97
Maximum Peak Power ² (kW)	70	142	220



Model	GVM210-200	GVM210-300	GVM210-400
Page	40 – 43	44 – 47	48 – 51
Max. Torque Output Range (Nm)			
Peak	315	527	703
Continuous	149	252	406
Winding Choices Available			
350 VDC	11	9	4
650 VDC	11	10	9
Base Speed ¹ (RPM)			
350 VDC	1327 – 5012	1023 – 2795	1216 – 1763
650 VDC	1271 – 5814	1735 – 5285	1268 – 3357
Peak Power ¹ (kW)			
350 VDC	51 – 186	63 – 173	102 – 147
650 VDC	48 – 214	108 – 325	107 – 279
Rated Shaft Output Power ¹ (kW)			
350 VDC	33 – 97	47 – 117	76 – 106
650 VDC	31 – 103	78 – 182	79 – 184
Maximum Peak Power ² (kW)	323	421	625

¹ Rated value dependant on winding selection

² Maximum peak power shows performance of the motor at base speeds of ~7500 rpm. Contact factory for details

GVM142 Accessory Motors & Generators

GVM142-050 Performance @ 48 VDC

Parameter	GVM142-050L	GVM142-050M	GVM142-050N	GVM142-050P	GVM142-050Q	GVM142-050R	
Peak Torque (Nm)	32	32	32	32	32	33	
Peak Power (kW)	4	5	7	9	12	13	
Stall Torque Continuous (Nm)	17	17	17	17	17	17	
Rated Torque (Nm)	Liquid Cooled*	15	15	15	15	15	
	Air Cooled	11	11	11	11	11	
Rated Speed (RPM)	Liquid Cooled*	1,669	2,210	2,723	3,514	4,620	4,966
	Air Cooled	1,642	2,148	2,647	3,376	4,285	4,606
Rated Shaft Output Power (kW)	Liquid Cooled*	3	3	4	6	7	8
	Air Cooled	2	3	3	4	5	5
Max Continuous Speed (RPM)	Liquid Cooled*	2,532	3,244	3,934	4,997	6,370	6,847
	Air Cooled	2,449	3,103	3,763	4,726	5,820	6,256
Stall Current Peak (Amp RMS)	109	138	171	216	274	301	
Stall Current Continuous (Amp RMS)	54	69	85	108	137	150	
Coolant Temperature (°C)*	60	60	60	60	60	60	
Ambient Temperature (°C)**	45	45	45	45	45	45	
Max Winding Temperature (°C)	180	180	180	180	180	180	
Winding Temperature at Rating (°C)	140	140	140	140	140	140	
Rotor Inertia (kg-m ²)	0.000273483	0.000273483	0.000273483	0.000273483	0.000273483	0.000273483	
Motor Weight (kg)	11.0	11.0	11.0	11.0	11.0	11.0	

Parameter	GVM142-050S	GVM142-050T	GVM142-050V	GVM142-050W	GVM142-050Y	GVM142-050Z	
Peak Torque (Nm)	32	32	32	33	32	32	
Peak Power (kW)	15	17	19	21	24	27	
Stall Torque Continuous (Nm)	17	17	17	17	17	14	
Rated Torque (Nm)	Liquid Cooled*	15	14	15	14	13	
	Air Cooled	10	10	10	9	8	
Rated Speed (RPM)	Liquid Cooled*	5,743	6,382	6,955	7,886	8,658	10,318
	Air Cooled	5,373	5,809	6,451	7,121	7,448	7,453
Rated Shaft Output Power (kW)	Liquid Cooled*	9	10	11	12	13	14
	Air Cooled	6	6	6	7	7	7
Max Continuous Speed (RPM)	Liquid Cooled*	8,040	8,800	9,737	10,874	12,310	14,227
	Air Cooled	7,087	7,661	8,268	9,000	9,683	10,434
Stall Current Peak (Amp RMS)	345	383	426	478	539	613	
Stall Current Continuous (Amp RMS)	173	192	213	239	260	260	
Coolant Temperature (°C)*	60	60	60	60	60	60	
Ambient Temperature (°C)**	45	45	45	45	45	45	
Max Winding Temperature (°C)	180	180	180	180	180	180	
Winding Temperature at Rating (°C)	140	140	140	140	140	135	
Rotor Inertia (kg-m ²)	0.000273483	0.000273483	0.000273483	0.000273483	0.000273483	0.000273483	
Motor Weight (kg)	11.0	11.0	11.0	11.0	11.0	11.0	

* 50/50 water/glycol mixture, consult Parker Engineering for other coolants

** With 5 m/sec airflow

Contact Parker for compatible inverter recommendations

GVM142-050 Winding Performance & Selection @ 48 VDC (Liquid Cooled Models Shown)

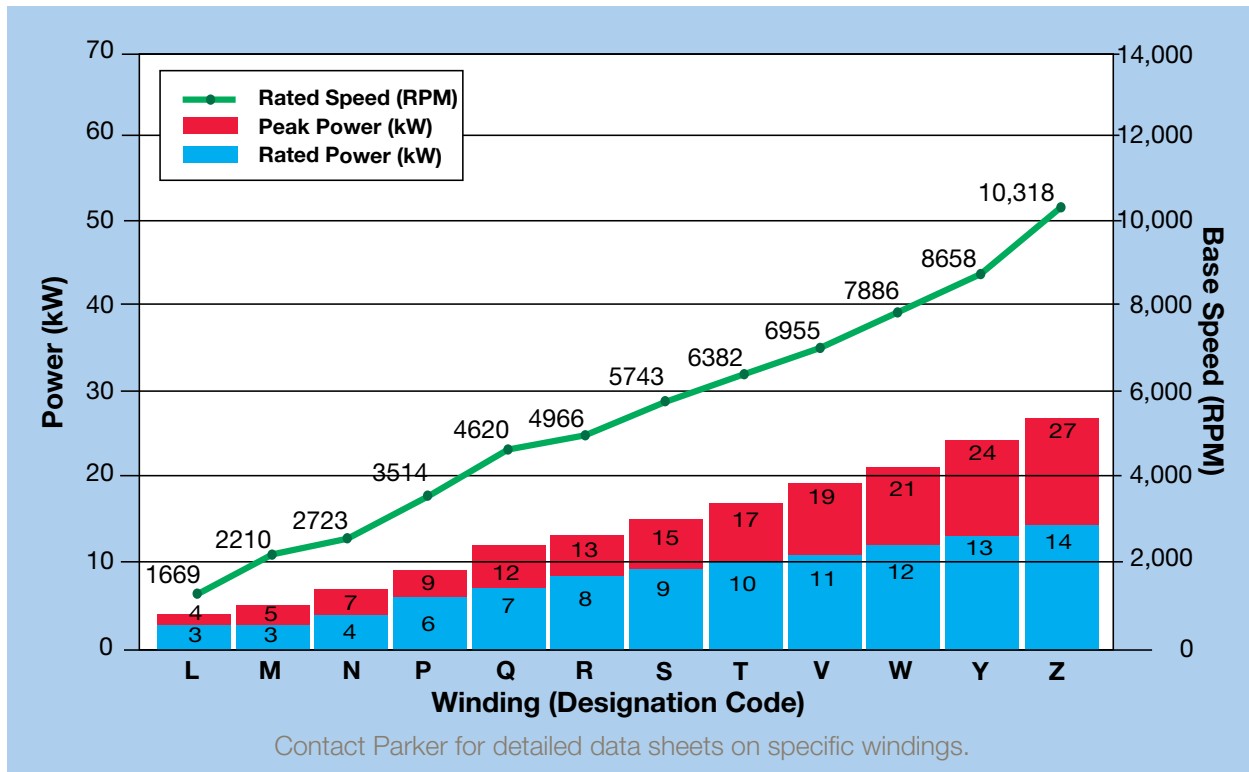

GVM142-050 Dimensions

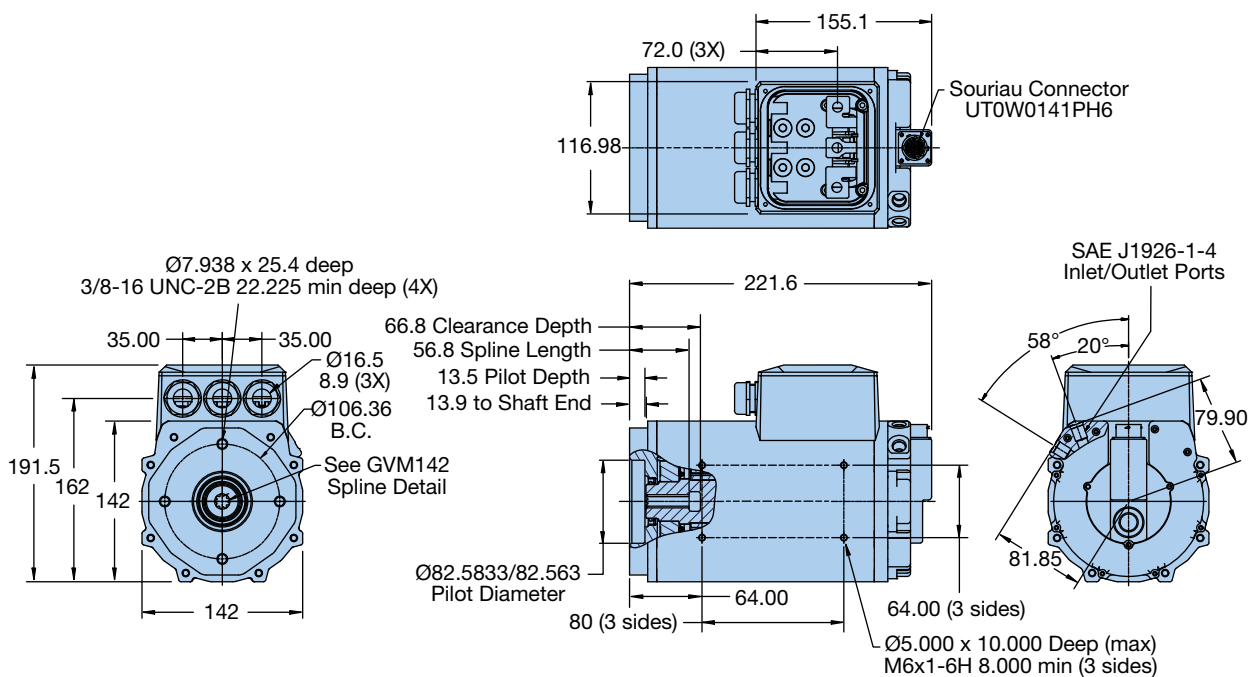

GVM142 Accessory Motors & Generators

GVM142-050 Performance @ 96 VDC

Parameter	GVM142-050H	GVM142-050J	GVM142-050K	GVM142-050L	GVM142-050M	
Peak Torque (Nm)	31	32	32	32	32	
Peak Power (kW)	4	5	7	9	12	
Stall Torque Continuous (Nm)	17	17	17	17	17	
Rated Torque (Nm)	Liquid Cooled*	15	15	15	15	
	Air Cooled	11	11	11	10	
Rated Speed (RPM)	Liquid Cooled*	1,729	2,229	2,858	3,617	4,562
	Air Cooled	1,709	2,167	2,703	3,382	4,364
Rated Shaft Output Power (kW)	Liquid Cooled*	3	3	4	6	7
	Air Cooled	2	3	3	4	5
Max Continuous Speed (RPM)	Liquid Cooled*	2,622	3,271	4,063	5,063	6,487
	Air Cooled	2,508	3,130	3,843	4,735	5,927
Stall Current Peak (Amp RMS)	55	69	87	109	138	
Stall Current Continuous (Amp RMS)	28	35	43	54	69	
Coolant Temperature (°C)*	60	60	60	60	60	
Ambient Temperature (°C)**	45	45	45	45	45	
Max Winding Temperature (°C)	180	180	180	180	180	
Winding Temperature at Rating (°C)	140	140	140	140	140	
Rotor Inertia (kg-m ²)	0.000273483	0.000273483	0.000273483	0.000273483	0.000273483	
Motor Weight (kg)	11.0	11.0	11.0	11.0	11.0	

Parameter	GVM142-050N	GVM142-050P	GVM142-050Q	GVM142-050R	GVM142-050S	
Peak Torque (Nm)	32	32	32	33	32	
Peak Power (kW)	15	19	24	27	31	
Stall Torque Continuous (Nm)	17	17	17	17	17	
Rated Torque (Nm)	Liquid Cooled*	15	14	14	15	14
	Air Cooled	10	9	8	9	8
Rated Speed (RPM)	Liquid Cooled*	5,619	7,138	8,820	9,480	11,009
	Air Cooled	5,245	6,547	7,495	7,495	7,455
Rated Shaft Output Power (kW)	Liquid Cooled*	9	11	13	14	16
	Air Cooled	6	6	7	7	7
Max Continuous Speed (RPM)	Liquid Cooled*	7,867	9,993	12,739	13,694	15,902
	Air Cooled	7,019	8,391	9,885	10,335	10,768
Stall Current Peak (Amp RMS)	171	216	274	301	345	
Stall Current Continuous (Amp RMS)	85	108	137	150	173	
Coolant Temperature (°C)*	60	60	60	60	60	
Ambient Temperature (°C)**	45	45	45	45	45	
Max Winding Temperature (°C)	180	180	180	180	180	
Winding Temperature at Rating (°C)	140	140	140	140	140	
Rotor Inertia (kg-m ²)	0.000273483	0.000273483	0.000273483	0.000273483	0.000273483	
Motor Weight (kg)	11.0	11.0	11.0	11.0	11.0	

* 50/50 water/glycol mixture, consult Parker Engineering for other coolants

** With 5 m/sec airflow

Contact Parker for compatible inverter recommendations

GVM142-050 Winding Performance & Selection @ 96 VDC (Liquid Cooled Models Shown)

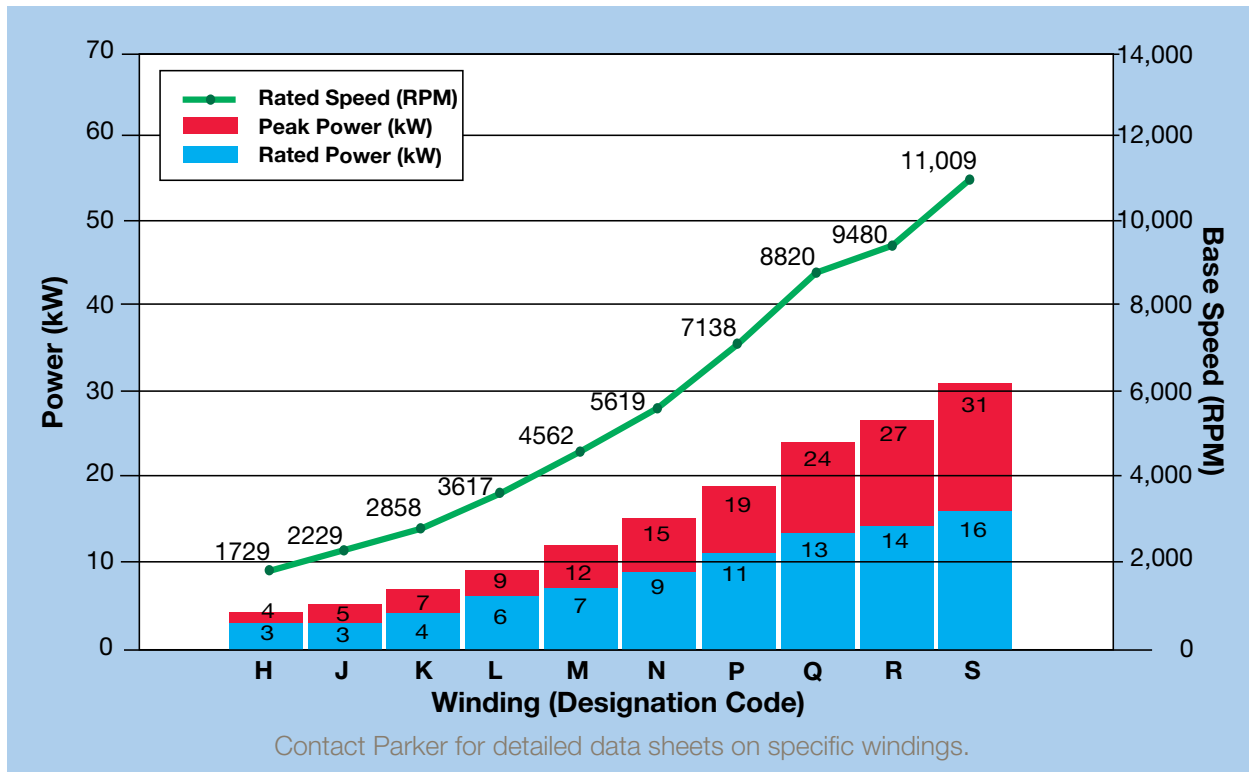

GVM142-050 Dimensions

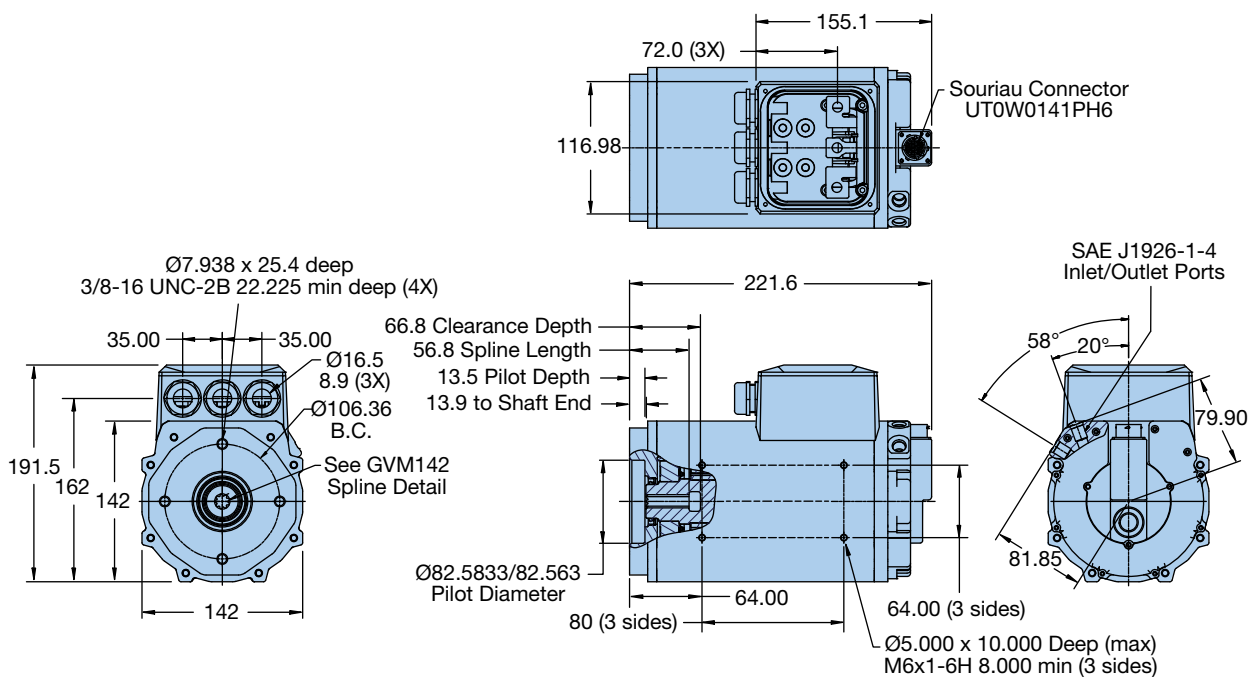

GVM142 Accessory Motors & Generators

GVM142-050 Performance @ 350 VDC

Parameter	GVM142-050C	GVM142-050D	GVM142-050F	GVM142-050G
Peak Torque (Nm)	30	31	31	31
Peak Power (kW)	4	7	11	14
Stall Torque Continuous (Nm)	16	16	16	16
Rated Torque (Nm)	Liquid Cooled*	14	14	14
	Air Cooled	11	11	10
Rated Speed (RPM)	Liquid Cooled*	1,699	2,752	4,328
	Air Cooled	1,642	2,656	4,140
Rated Shaft Output Power (kW)	Liquid Cooled*	3	4	7
	Air Cooled	2	3	5
Max Continuous Speed (RPM)	Liquid Cooled*	2,577	3,976	6,154
	Air Cooled	2,411	3,718	5,623
Stall Current Peak (Amp RMS)	14	22	35	44
Stall Current Continuous (Amp RMS)	7	11	18	22
Coolant Temperature (°C)*	60	60	60	60
Ambient Temperature (°C)**	45	45	45	45
Max Winding Temperature (°C)	180	180	180	180
Winding Temperature at Rating (°C)	140	140	140	140
Rotor Inertia (kg-m ²)	0.000273483	0.000273483	0.000273483	0.000273483
Motor Weight (kg)	11.0	11.0	11.0	11.0

Parameter	GVM142-050H	GVM142-050J	GVM142-050K	GVM142-050L
Peak Torque (Nm)	31	32	32	32
Peak Power (kW)	18	23	29	36
Stall Torque Continuous (Nm)	17	17	17	17
Rated Torque (Nm)	Liquid Cooled*	14	14	13
	Air Cooled	9	8	8
Rated Speed (RPM)	Liquid Cooled*	6,722	8,388	10,089
	Air Cooled	6,333	7,506	7,446
Rated Shaft Output Power (kW)	Liquid Cooled*	10	12	15
	Air Cooled	6	7	7
Max Continuous Speed (RPM)	Liquid Cooled*	9,558	11,927	14,808
	Air Cooled	8,116	9,487	10,587
Stall Current Peak (Amp RMS)	55	69	87	109
Stall Current Continuous (Amp RMS)	28	35	43	54
Coolant Temperature (°C)*	60	60	60	60
Ambient Temperature (°C)**	45	45	45	45
Max Winding Temperature (°C)	180	180	180	180
Winding Temperature at Rating (°C)	140	140	140	140
Rotor Inertia (kg-m ²)	0.000273483	0.000273483	0.000273483	0.000273483
Motor Weight (kg)	11.0	11.0	11.0	11.0

* 50/50 water/glycol mixture, consult Parker Engineering for other coolants

** With 5 m/sec airflow

Contact Parker for compatible inverter recommendations

GVM142-050 Winding Performance & Selection @ 350 VDC (Liquid Cooled Models Shown)

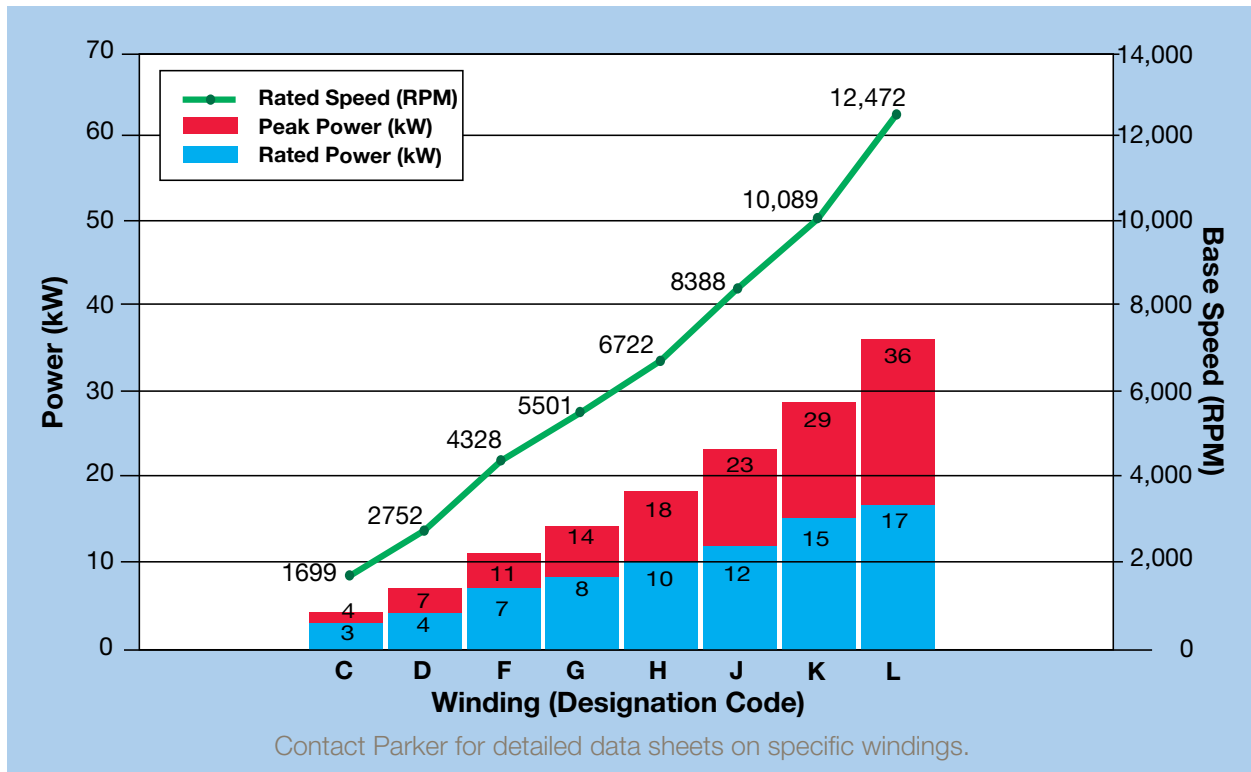

GVM142-050 Dimensions

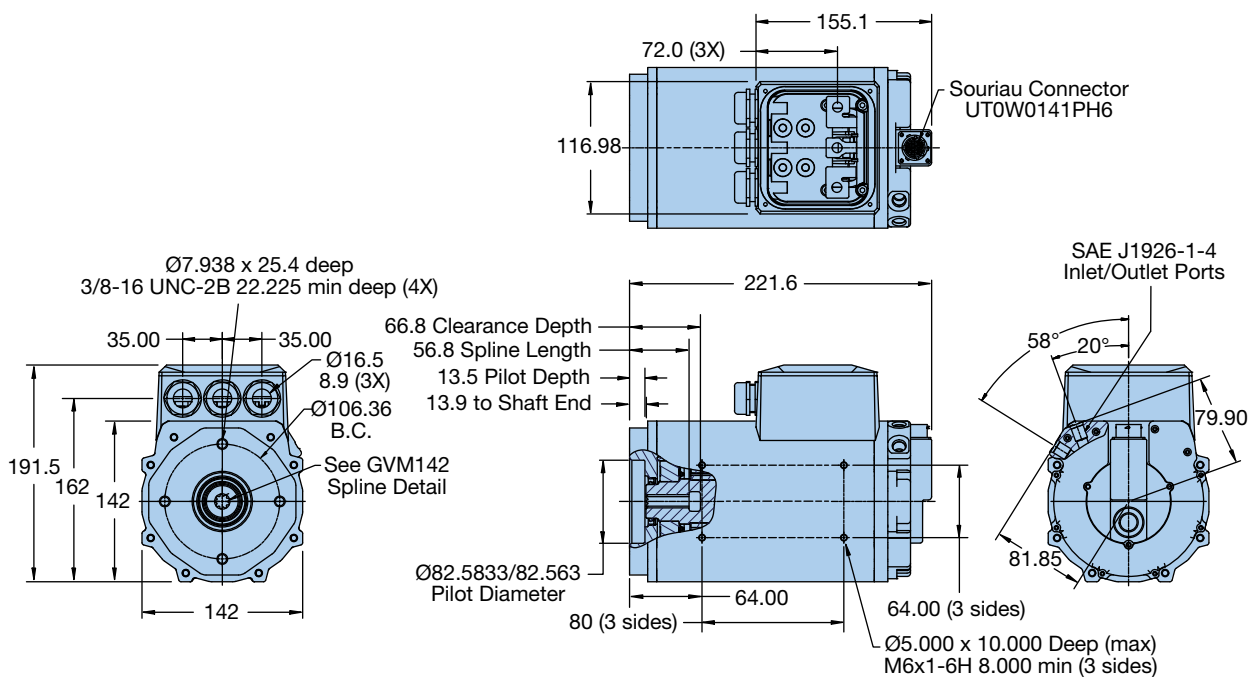

GVM142 Accessory Motors & Generators

GVM142-075 Performance @ 48 VDC

Parameter	GVM142-075M	GVM142-075N	GVM142-075P	GVM142-075Q	GVM142-075R	GVM142-075S	
Peak Torque (Nm)	49	50	50	49	50	49	
Peak Power (kW)	5	7	9	12	13	15	
Stall Torque Continuous (Nm)	26	26	26	26	27	26	
Rated Torque (Nm)	Liquid Cooled*	22	23	23	23	23	
	Air Cooled	17	17	17	17	17	
Rated Speed (RPM)	Liquid Cooled*	1,449	1,815	2,305	3036	3,260	3,885
	Air Cooled	1,409	1,728	2,205	2,872	3,084	3,592
Rated Shaft Output Power (kW)	Liquid Cooled*	3	4	6	7	8	9
	Air Cooled	3	3	4	5	6	6
Max Continuous Speed (RPM)	Liquid Cooled*	2,162	2,622	3,330	4,250	4,565	5,357
	Air Cooled	2,068	2,537	3,186	4,020	4,318	4,952
Stall Current Peak (Amp RMS)	144	178	225	285	313	359	
Stall Current Continuous (Amp RMS)	72	89	112	143	157	180	
Coolant Temperature (°C)*	60	60	60	60	60	60	
Ambient Temperature (°C)**	45	45	45	45	45	45	
Max Winding Temperature (°C)	180	180	180	180	180	180	
Winding Temperature at Rating (°C)	140	140	140	140	140	140	
Rotor Inertia (kg-m ²)	0.000314706	0.000314706	0.000314706	0.000314706	0.000314706	0.000314706	
Motor Weight (kg)	13.3	13.3	13.3	13.3	13.3	13.3	

Parameter	GVM142-075T	GVM142-075V	GVM142-075W	GVM142-075Y	GVM142-075Z	
Peak Torque (Nm)	50	50	50	50	50	
Peak Power (kW)	17	19	21	24	27	
Stall Torque Continuous (Nm)	27	27	27	25	22	
Rated Torque (Nm)	Liquid Cooled*	23	23	23	22	19
	Air Cooled	16	16	16	15	14
Rated Speed (RPM)	Liquid Cooled*	4,255	4,702	5,254	5,963	6,879
	Air Cooled	3,946	4,374	4,829	5,427	6,204
Rated Shaft Output Power (kW)	Liquid Cooled*	10	11	13	14	14
	Air Cooled	7	7	8	9	9
Max Continuous Speed (RPM)	Liquid Cooled*	5,866	6,483	7,244	8,221	9,485
	Air Cooled	5,360	5,853	6,462	7,158	7,952
Stall Current Peak (Amp RMS)	399	444	497	561	638	
Stall Current Continuous (Amp RMS)	199	222	249	260	260	
Coolant Temperature (°C)*	60	60	60	60	60	
Ambient Temperature (°C)**	45	45	45	45	45	
Max Winding Temperature (°C)	180	180	180	180	180	
Winding Temperature at Rating (°C)	140	140	140	137	123	
Rotor Inertia (kg-m ²)	0.000314706	0.000314706	0.000314706	0.000314706	0.000314706	
Motor Weight (kg)	13.3	13.3	13.3	13.3	13.3	

* 50/50 water/glycol mixture, consult Parker Engineering for other coolants

** With 5 m/sec airflow

Contact Parker for compatible inverter recommendations

GVM142-075 Winding Performance & Selection @ 48 VDC (Liquid Cooled Models Shown)

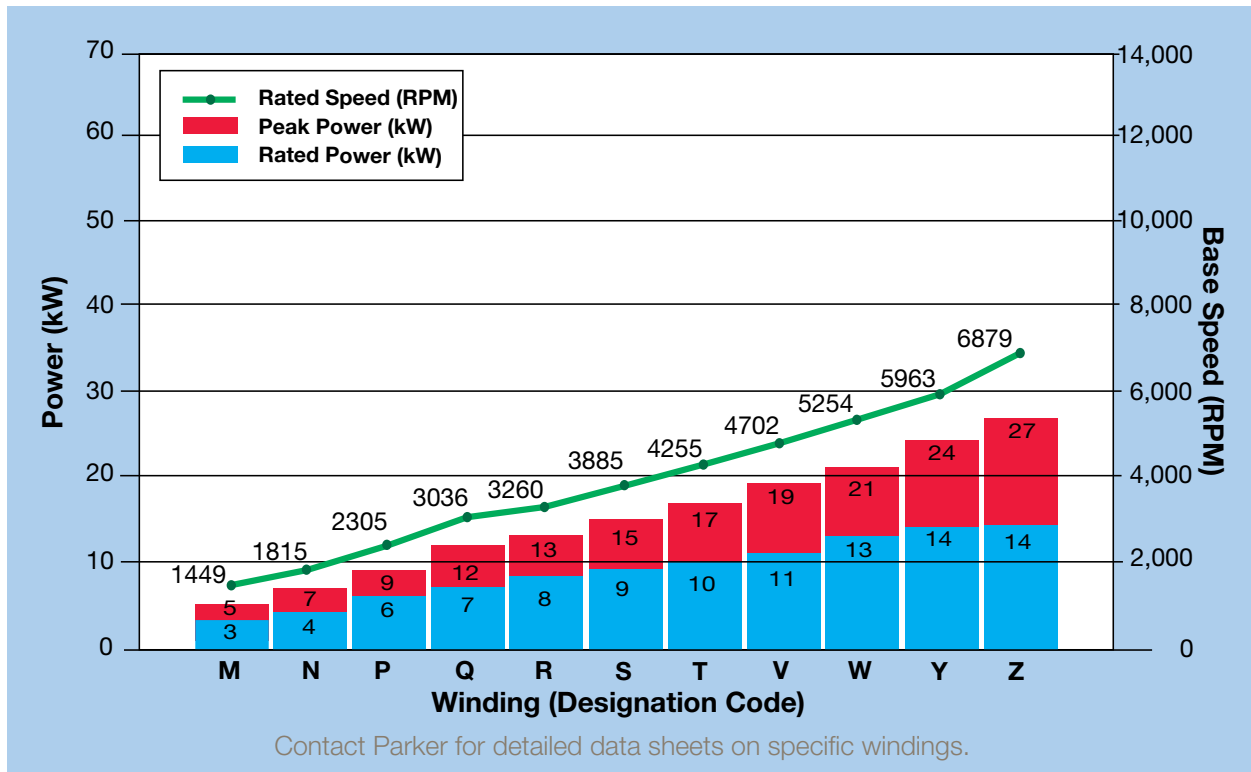

GVM142-075 Dimensions

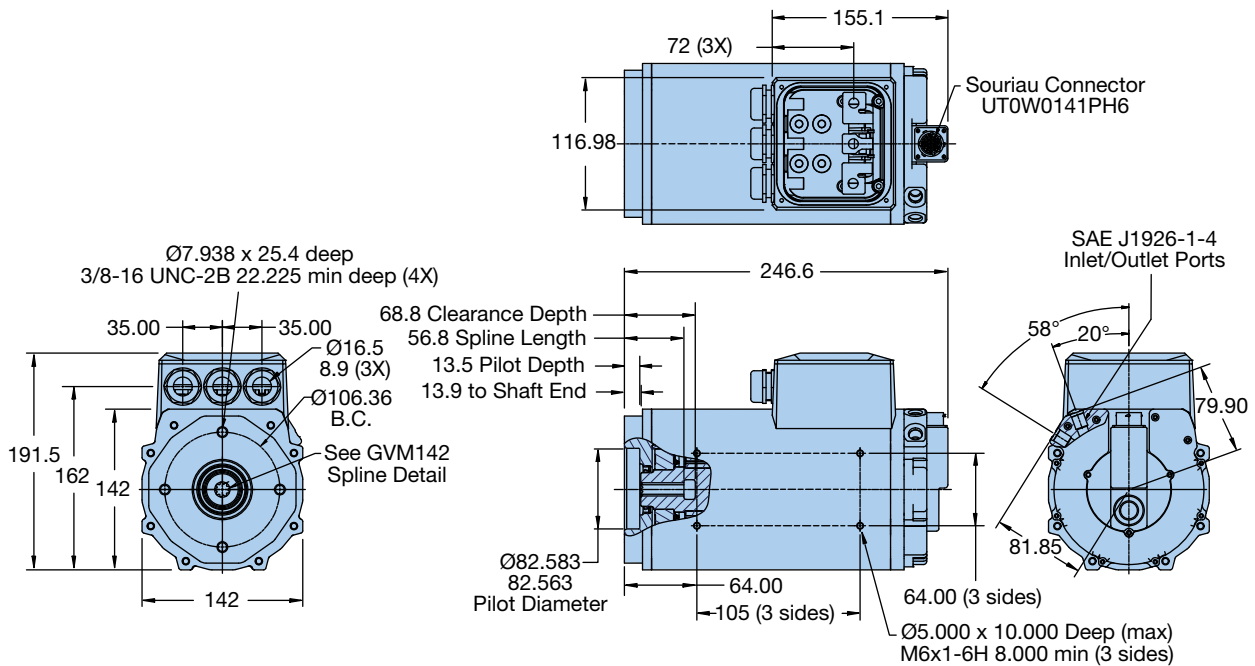

GVM142 Accessory Motors & Generators

GVM142-075 Performance @ 96 VDC

Parameter	GVM142-075J	GVM142-075K	GVM142-075L	GVM142-075M	GVM142-075N	GVM142-075P	
Peak Torque (Nm)	49	49	49	49	50	50	
Peak Power (kW)	5	7	9	12	15	19	
Stall Torque Continuous (Nm)	26	26	26	26	26	26	
Rated Torque (Nm)	Liquid Cooled*	23	23	23	23	23	
	Air Cooled	17	17	17	17	16	
Rated Speed (RPM)	Liquid Cooled*	1,438	1,815	2,374	3,088	3,804	4,830
	Air Cooled	1,398	1,794	2,236	2,933	3,518	4,493
Rated Shaft Output Power (kW)	Liquid Cooled*	3	4	6	7	9	11
	Air Cooled	3	3	4	5	6	7
Max Continuous Speed (RPM)	Liquid Cooled*	2,181	2,708	3,376	4,324	5,245	6,660
	Air Cooled	2,086	2,591	3,230	4,043	4,850	6,013
Stall Current Peak (Amp RMS)	72	90	113	144	178	225	
Stall Current Continuous (Amp RMS)	36	45	57	72	89	112	
Coolant Temperature (°C)*	60	60	60	60	60	60	
Ambient Temperature (°C)**	45	45	45	45	45	45	
Max Winding Temperature (°C)	180	180	180	180	180	180	
Winding Temperature at Rating (°C)	140	140	140	140	140	140	
Rotor Inertia (kg-m ²)	0.000314706	0.000314706	0.000314706	0.000314706	0.000314706	0.000314706	
Motor Weight (kg)	13.3	13.3	13.3	13.3	13.3	13.3	

Parameter	GVM142-075Q	GVM142-075R	GVM142-075S	GVM142-075V	GVM142-075W	
Peak Torque (Nm)	49	50	49	50	50	
Peak Power (kW)	25	27	31	39	43	
Stall Torque Continuous (Nm)	26	27	26	27	24	
Rated Torque (Nm)	Liquid Cooled*	22	23	22	22	
	Air Cooled	15	15	13	13	
Rated Speed (RPM)	Liquid Cooled*	6,165	6,521	7,653	8,976	10,030
	Air Cooled	5,623	5,963	6,852	6,792	6,823
Rated Shaft Output Power (kW)	Liquid Cooled*	14	16	18	21	23
	Air Cooled	9	9	9	9	9
Max Continuous Speed (RPM)	Liquid Cooled*	8,500	9,129	10,714	12,965	14,487
	Air Cooled	7,310	7,752	8,541	9,509	9,855
Stall Current Peak (Amp RMS)	285	313	359	444	497	
Stall Current Continuous (Amp RMS)	143	157	180	220	220	
Coolant Temperature (°C)*	60	60	60	60	60	
Ambient Temperature (°C)**	45	45	45	45	45	
Max Winding Temperature (°C)	180	180	180	180	180	
Winding Temperature at Rating (°C)	140	140	140	140	140	
Rotor Inertia (kg-m ²)	0.000314706	0.000314706	0.000314706	0.000314706	0.000314706	
Motor Weight (kg)	13.3	13.3	13.3	13.3	13.3	

* 50/50 water/glycol mixture, consult Parker Engineering for other coolants

** With 5 m/sec airflow

Contact Parker for compatible inverter recommendations

GVM142-075 Winding Performance & Selection @ 96 VDC (Liquid Cooled Models Shown)

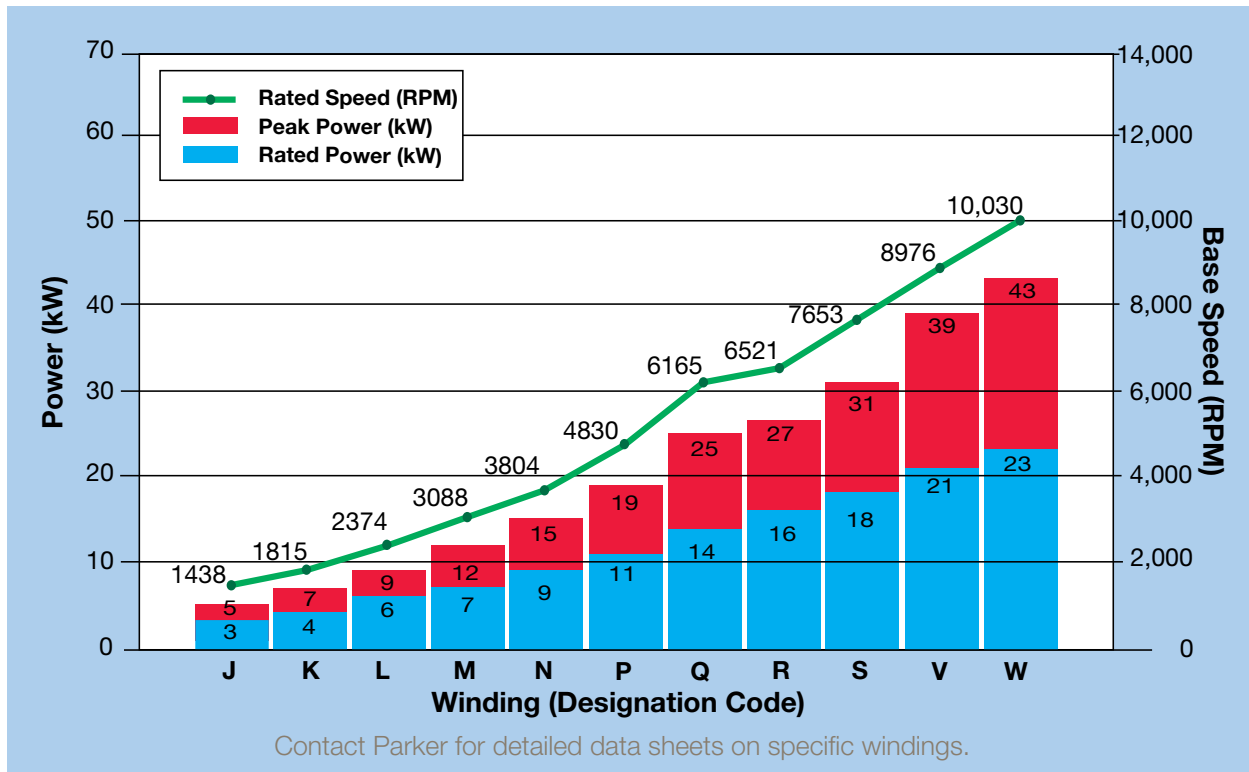

GVM142-075 Dimensions

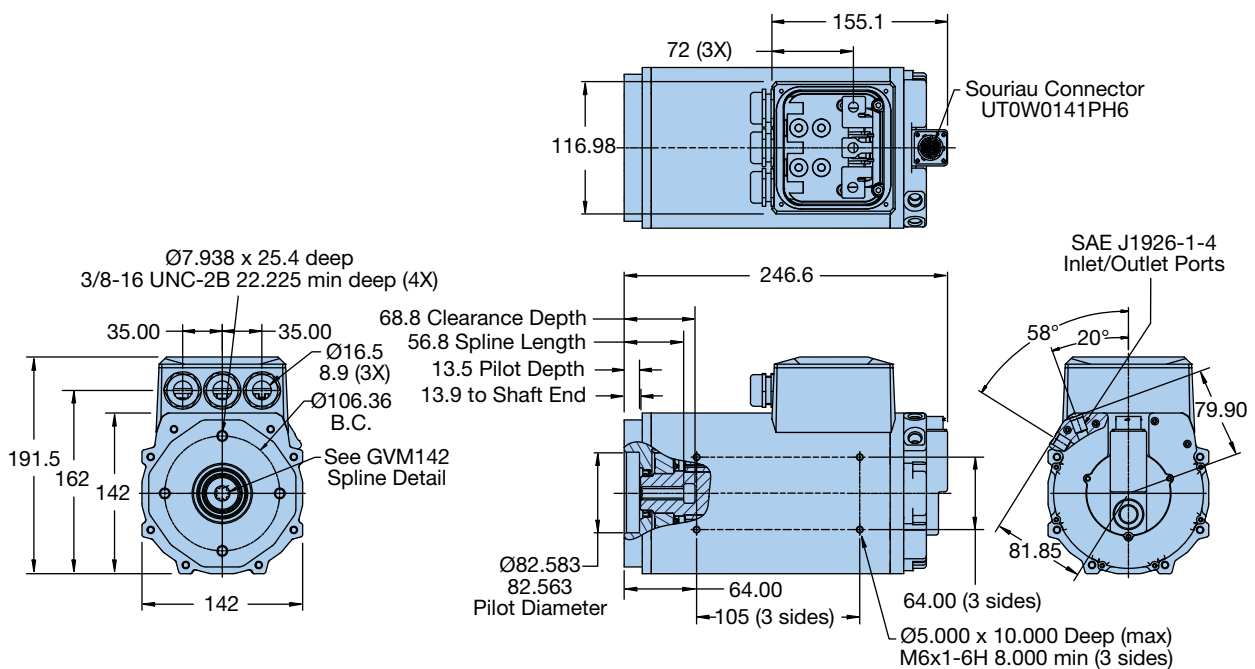

GVM142 Accessory Motors & Generators

GVM142-075 Performance @ 350 VDC

Parameter	GVM142-075D	GVM142-075F	GVM142-075G	GVM142-075H	GVM142-075J	
Peak Torque (Nm)	48	48	48	49	49	
Peak Power (kW)	6	11	14	18	23	
Stall Torque Continuous (Nm)	25	25	26	26	26	
Rated Torque (Nm)	Liquid Cooled*	23	23	22	22	
	Air Cooled	17	16	16	15	
Rated Speed (RPM)	Liquid Cooled*	1,747	2,840	3,668	4,622	5,766
	Air Cooled	1,708	2,741	3,456	4,300	5,266
Rated Shaft Output Power (kW)	Liquid Cooled*	4	7	9	11	13
	Air Cooled	3	5	6	7	8
Max Continuous Speed (RPM)	Liquid Cooled*	2,650	4,103	5,135	6,373	7,950
	Air Cooled	2,507	3,837	4,694	5,754	6,845
Stall Current Peak (Amp RMS)	23	37	46	57	72	
Stall Current Continuous (Amp RMS)	12	18	23	29	36	
Coolant Temperature (°C)*	60	60	60	60	60	
Ambient Temperature (°C)**	45	45	45	45	45	
Max Winding Temperature (°C)	180	180	180	180	180	
Winding Temperature at Rating (°C)	140	140	140	140	140	
Rotor Inertia (kg-m ²)	0.000314706	0.000314706	0.000314706	0.000314706	0.000314706	
Motor Weight (kg)	13.3	13.3	13.3	13.3	13.3	

Parameter	GVM142-075K	GVM142-075L	GVM142-075M	GVM142-075N	
Peak Torque (Nm)	49	49	49	46	
Peak Power (kW)	29	36	47	56	
Stall Torque Continuous (Nm)	26	26	26	24	
Rated Torque (Nm)	Liquid Cooled*	22	22	21	20
	Air Cooled	13	13	13	13
Rated Speed (RPM)	Liquid Cooled*	7,161	8,521	10,725	12,671
	Air Cooled	6,483	6,839	6,844	6,817
Rated Shaft Output Power (kW)	Liquid Cooled*	16	20	24	27
	Air Cooled	9	9	9	9
Max Continuous Speed (RPM)	Liquid Cooled*	9,874	12,308	15,250	17,470
	Air Cooled	8,082	9,289	9,886	9,847
Stall Current Peak (Amp RMS)	90	113	144	160	
Stall Current Continuous (Amp RMS)	45	57	72	80	
Coolant Temperature (°C)*	60	60	60	60	
Ambient Temperature (°C)**	45	45	45	45	
Max Winding Temperature (°C)	180	180	180	180	
Winding Temperature at Rating (°C)	140	140	140	140	
Rotor Inertia (kg-m ²)	0.000314706	0.000314706	0.000314706	0.000314706	
Motor Weight (kg)	13.3	13.3	13.3	13.3	

* 50/50 water/glycol mixture, consult Parker Engineering for other coolants

** With 5 m/sec airflow

Contact Parker for compatible inverter recommendations

GVM142-075 Winding Performance & Selection @ 350 VDC (Liquid Cooled Models Shown)

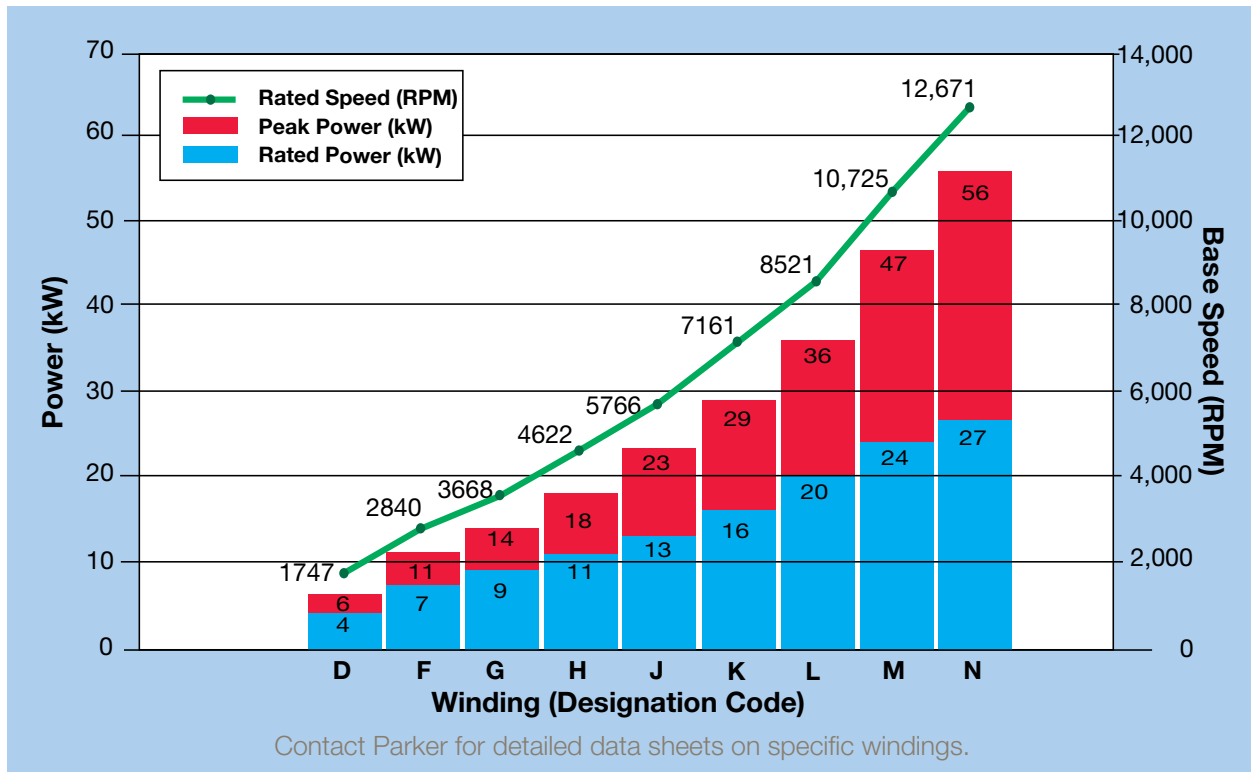

GVM142-075 Dimensions

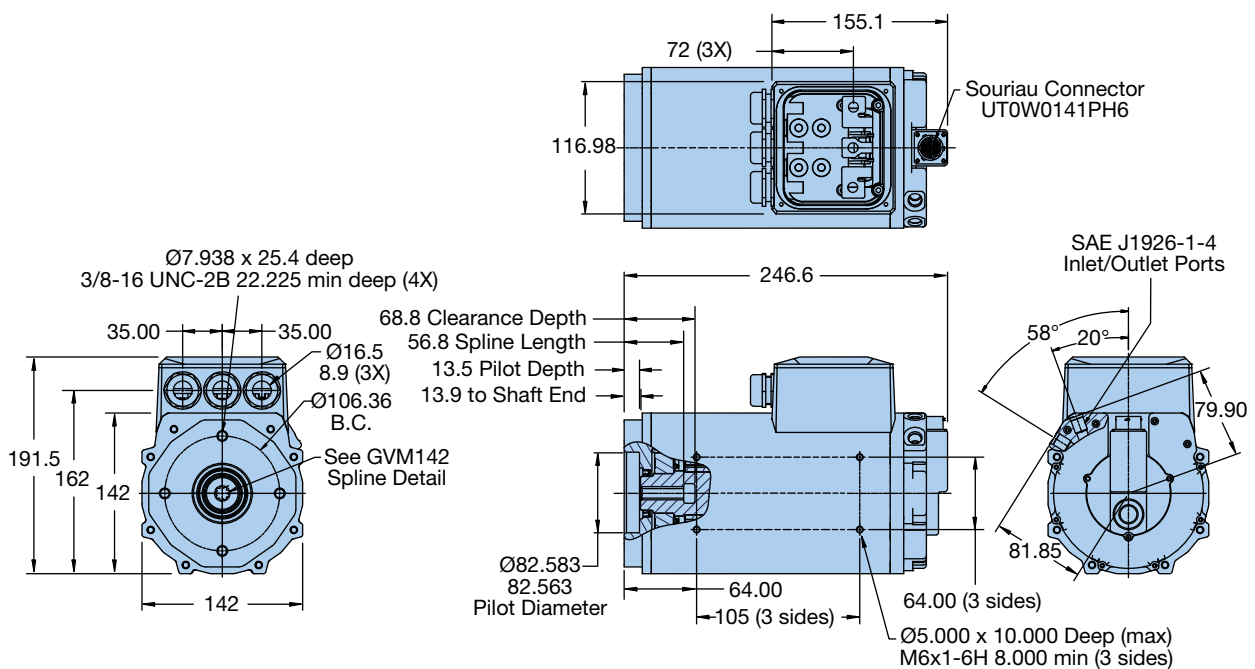

GVM142 Accessory Motors & Generators

GVM142-100 Performance @ 48 VDC

Parameter	GVM142-100M	GVM142-100N	GVM142-100P	GVM142-100Q	GVM142-100R	GVM142-100S	
Peak Torque (Nm)	66	67	67	66	67	66	
Peak Power (kW)	5	6	8	11	12	15	
Stall Torque Continuous (Nm)	35	36	35	35	36	35	
Rated Torque (Nm)	Liquid Cooled*	31	31	31	31	31	
	Air Cooled	23	23	23	23	22	
Rated Speed (RPM)	Liquid Cooled*	1,033	1,296	1,702	2,241	2,445	2,869
	Air Cooled	1,023	1,275	1,673	2,144	2,303	2,714
Rated Shaft Output Power (kW)	Liquid Cooled*	3	4	6	7	8	9
	Air Cooled	3	3	4	5	6	6
Max Continuous Speed (RPM)	Liquid Cooled*	1,621	1,966	2,498	3,187	3,423	4,017
	Air Cooled	1,551	1,902	2,417	3,049	3,275	3,799
Stall Current Peak (Amp RMS)	145	179	226	287	316	362	
Stall Current Continuous (Amp RMS)	72	90	113	144	158	181	
Coolant Temperature (°C)*	60	60	60	60	60	60	
Ambient Temperature (°C)**	45	45	45	45	45	45	
Max Winding Temperature (°C)	180	180	180	180	180	180	
Winding Temperature at Rating (°C)	140	140	140	140	140	140	
Rotor Inertia (kg-m ²)	0.000355927	0.000355927	0.000355927	0.000355927	0.000355927	0.000355927	
Motor Weight (kg)	15.7	15.7	15.7	15.7	15.7	15.7	

Parameter	GVM142-100T	GVM142-100V	GVM142-100W	GVM142-100Y	GVM142-100Z	
Peak Torque (Nm)	67	67	67	67	66	
Peak Power (kW)	16	18	21	24	28	
Stall Torque Continuous (Nm)	36	36	36	33	29	
Rated Torque (Nm)	Liquid Cooled*	31	32	31	29	26
	Air Cooled	23	22	22	22	21
Rated Speed (RPM)	Liquid Cooled*	3,143	3,421	3,943	4,538	5,081
	Air Cooled	2,985	3,299	3,645	4,158	4,754
Rated Shaft Output Power (kW)	Liquid Cooled*	10	11	13	14	14
	Air Cooled	7	8	9	9	10
Max Continuous Speed (RPM)	Liquid Cooled*	4,400	4,864	5,437	6,163	7,113
	Air Cooled	4,115	4,548	5,026	5,565	6,270
Stall Current Peak (Amp RMS)	402	448	502	565	643	
Stall Current Continuous (Amp RMS)	201	224	251	260	260	
Coolant Temperature (°C)*	60	60	60	60	60	
Ambient Temperature (°C)**	45	45	45	45	45	
Max Winding Temperature (°C)	180	180	180	180	180	
Winding Temperature at Rating (°C)	140	140	140	133	119	
Rotor Inertia (kg-m ²)	0.000355927	0.000355927	0.000355927	0.000355927	0.000355927	
Motor Weight (kg)	15.7	15.7	15.7	15.7	15.7	

* 50/50 water/glycol mixture, consult Parker Engineering for other coolants

** With 5 m/sec airflow

Contact Parker for compatible inverter recommendations

GVM142-100 Winding Performance & Selection @ 48 VDC (Liquid Cooled Models Shown)

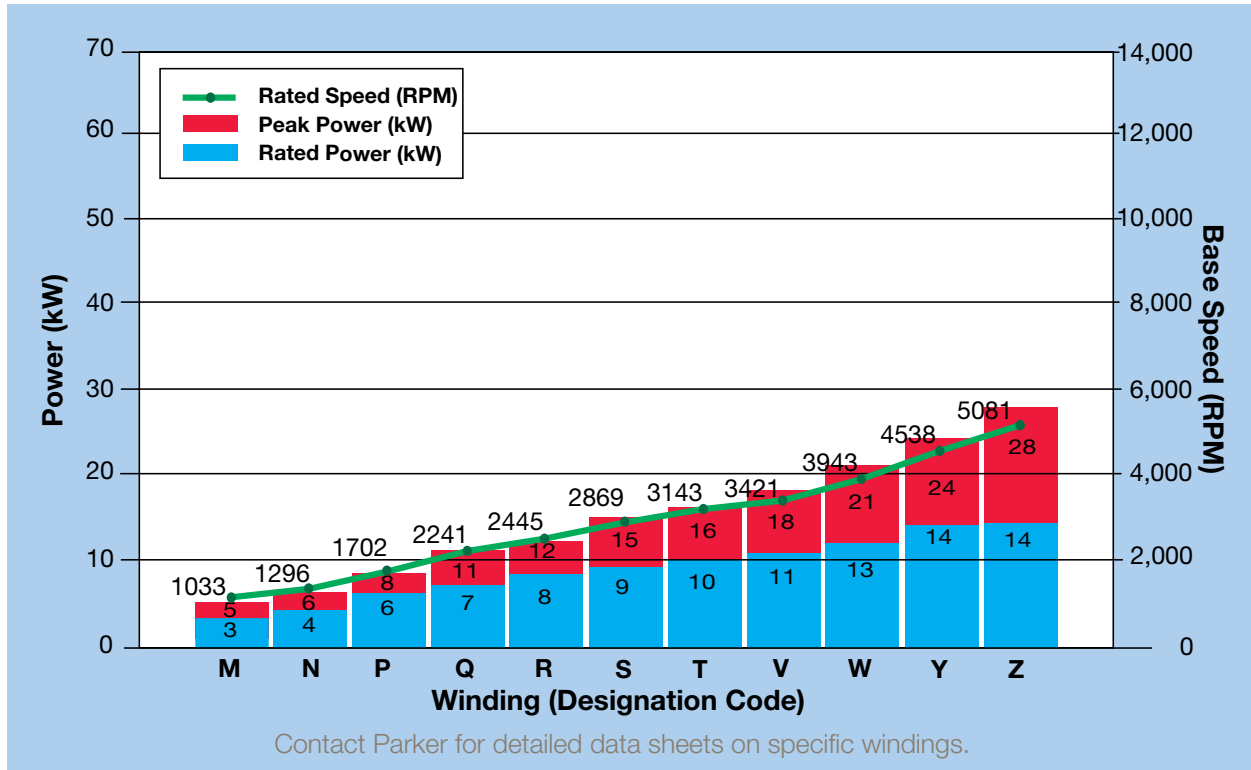

GVM142-100 Dimensions

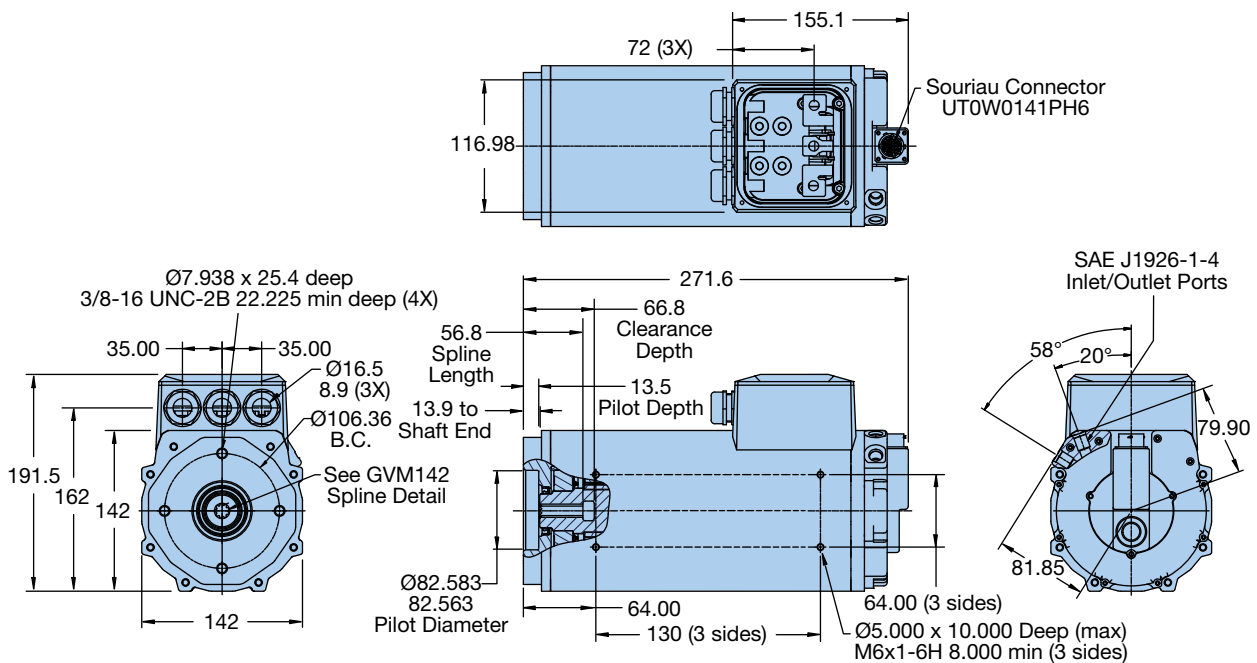

GVM142 Accessory Motors & Generators

GVM142-100 Performance @ 96 VDC

Parameter	GVM142-100J	GVM142-100K	GVM142-100L	GVM142-100M	GVM142-100N	GVM142-100P	
Peak Torque (Nm)	66	66	66	66	67	67	
Peak Power (kW)	5	6	8	11	14	19	
Stall Torque Continuous (Nm)	35	35	35	35	36	35	
Rated Torque (Nm)	Liquid Cooled*	30	30	30	31	30	
	Air Cooled	23	23	23	23	22	
Rated Speed (RPM)	Liquid Cooled*	1,043	1,362	1,753	2,245	2,809	3,624
	Air Cooled	1,032	1,324	1,677	2,157	2,657	3,350
Rated Shaft Output Power (kW)	Liquid Cooled*	3	4	6	7	9	12
	Air Cooled	2	3	4	5	6	8
Max Continuous Speed (RPM)	Liquid Cooled*	1,636	2,031	2,532	3,242	3,932	4,997
	Air Cooled	1,565	1,943	2,422	3,067	3,719	4,619
Stall Current Peak (Amp RMS)	73	91	114	145	179	226	
Stall Current Continuous (Amp RMS)	36	45	57	72	90	113	
Coolant Temperature (°C)*	60	60	60	60	60	60	
Ambient Temperature (°C)**	45	45	45	45	45	45	
Max Winding Temperature (°C)	180	180	180	180	180	180	
Winding Temperature at Rating (°C)	140	140	140	140	140	140	
Rotor Inertia (kg-m ²)	0.000355927	0.000355927	0.000355927	0.000355927	0.000355927	0.000355927	
Motor Weight (kg)	15.7	15.7	15.7	15.7	15.7	15.7	

Parameter	GVM142-100Q	GVM142-100R	GVM142-100S	GVM142-100V	GVM142-100W	
Peak Torque (Nm)	66	67	66	67	67	
Peak Power (kW)	25	27	31	39	43	
Stall Torque Continuous (Nm)	35	36	35	35	32	
Rated Torque (Nm)	Liquid Cooled*	31	31	30	28	
	Air Cooled	21	21	20	18	18
Rated Speed (RPM)	Liquid Cooled*	4,553	4,966	5,738	6,948	8,006
	Air Cooled	4,315	4,565	5,314	6,374	6,469
Rated Shaft Output Power (kW)	Liquid Cooled*	15	16	18	22	24
	Air Cooled	9	10	11	12	12
Max Continuous Speed (RPM)	Liquid Cooled*	6,374	6,847	8,033	9,727	10,874
	Air Cooled	5,691	6,108	6,908	7,946	8,532
Stall Current Peak (Amp RMS)	287	316	362	448	502	
Stall Current Continuous (Amp RMS)	144	158	181	220	220	
Coolant Temperature (°C)*	60	60	60	60	60	
Ambient Temperature (°C)**	45	45	45	45	45	
Max Winding Temperature (°C)	180	180	180	180	180	
Winding Temperature at Rating (°C)	140	140	140	140	136	
Rotor Inertia (kg-m ²)	0.000355927	0.000355927	0.000355927	0.000355927	0.000355927	
Motor Weight (kg)	15.7	15.7	15.7	15.7	15.7	

* 50/50 water/glycol mixture, consult Parker Engineering for other coolants

** With 5 m/sec airflow

Contact Parker for compatible inverter recommendations

GVM142-100 Winding Performance & Selection @ 96 VDC (Liquid Cooled Models Shown)

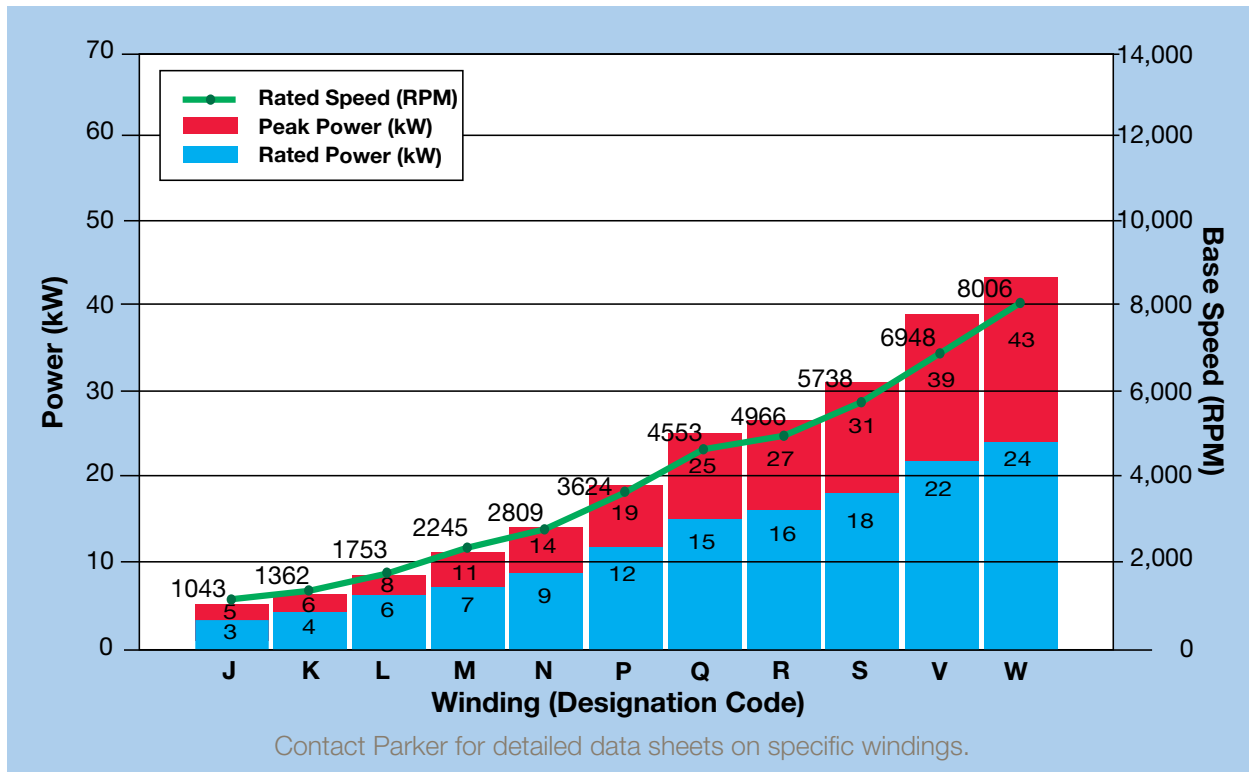

GVM142-100 Dimensions

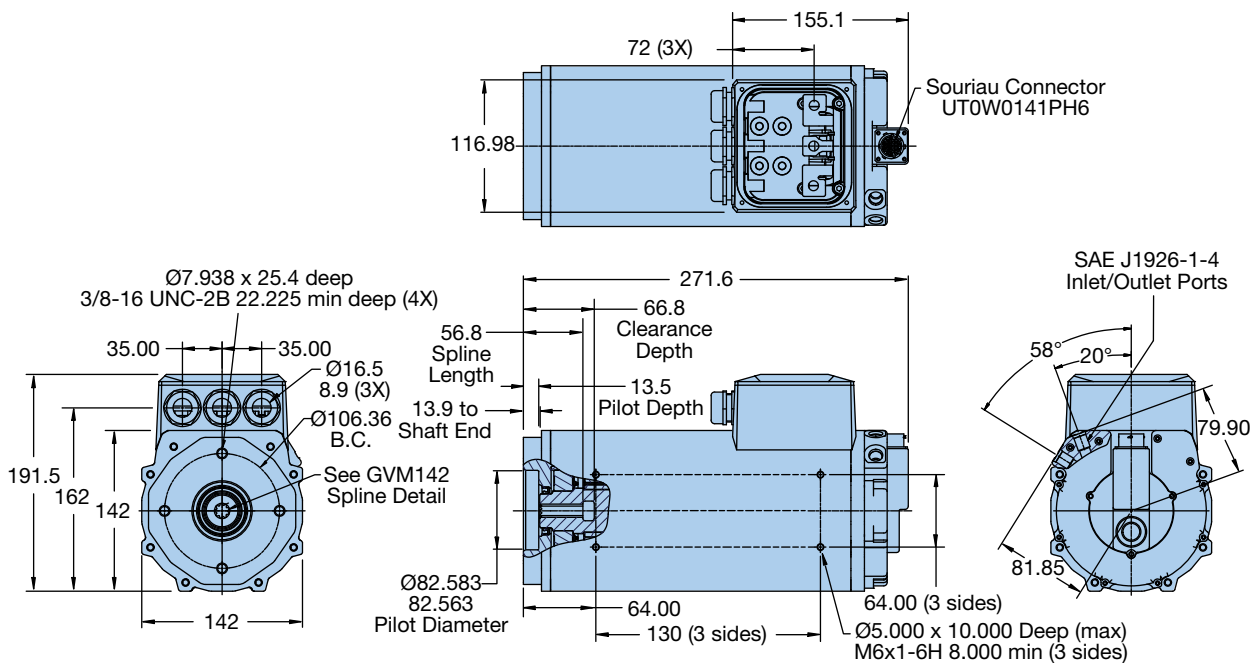

GVM142 Accessory Motors & Generators

GVM142-100 Performance @ 350 VDC

Parameter	GVM142-100D	GVM142-100F	GVM142-100G	GVM142-100H	GVM142-100J	
Peak Torque (Nm)	64	65	65	65	66	
Peak Power (kW)	6	11	14	18	23	
Stall Torque Continuous (Nm)	34	34	34	35	35	
Rated Torque (Nm)	Liquid Cooled*	30	30	31	30	
	Air Cooled	22	22	22	21	
Rated Speed (RPM)	Liquid Cooled*	1,267	2,096	2,666	3,361	4,260
	Air Cooled	1,281	2,047	2,572	3,204	4,024
Rated Shaft Output Power (kW)	Liquid Cooled*	4	7	9	11	14
	Air Cooled	3	5	6	7	9
Max Continuous Speed (RPM)	Liquid Cooled*	1,988	3,077	3,851	4,779	5,964
	Air Cooled	1,880	2,911	3,601	4,418	5,384
Stall Current Peak (Amp RMS)	23	37	46	58	73	
Stall Current Continuous (Amp RMS)	12	18	23	29	36	
Coolant Temperature (°C)*	60	60	60	60	60	
Ambient Temperature (°C)**	45	45	45	45	45	
Max Winding Temperature (°C)	180	180	180	180	180	
Winding Temperature at Rating (°C)	140	140	140	140	140	
Rotor Inertia (kg-m ²)	0.000355927	0.000355927	0.000355927	0.000355927	0.000355927	
Motor Weight (kg)	15.7	15.7	15.7	15.7	15.7	

Parameter	GVM142-100K	GVM142-100L	GVM142-100M	GVM142-100N	
Peak Torque (Nm)	66	66	66	61	
Peak Power (kW)	29	36	47	57	
Stall Torque Continuous (Nm)	35	35	35	32	
Rated Torque (Nm)	Liquid Cooled*	30	30	29	
	Air Cooled	20	18	17	
Rated Speed (RPM)	Liquid Cooled*	5,289	6,594	8,184	9,814
	Air Cooled	4,959	6,046	6,470	6,467
Rated Shaft Output Power (kW)	Liquid Cooled*	17	21	25	30
	Air Cooled	10	11	12	12
Max Continuous Speed (RPM)	Liquid Cooled*	7,405	9,232	11,821	14,176
	Air Cooled	6,447	7,641	8,921	9,341
Stall Current Peak (Amp RMS)	91	114	145	160	
Stall Current Continuous (Amp RMS)	45	57	72	80	
Coolant Temperature (°C)*	60	60	60	60	
Ambient Temperature (°C)**	45	45	45	45	
Max Winding Temperature (°C)	180	180	180	180	
Winding Temperature at Rating (°C)	140	140	140	140	
Rotor Inertia (kg-m ²)	0.000355927	0.000355927	0.000355927	0.000355927	
Motor Weight (kg)	15.7	15.7	15.7	15.7	

* 50/50 water/glycol mixture, consult Parker Engineering for other coolants

** With 5 m/sec airflow

Contact Parker for compatible inverter recommendations

GVM142-100 Winding Performance & Selection @ 350 VDC (Liquid Cooled Models Shown)

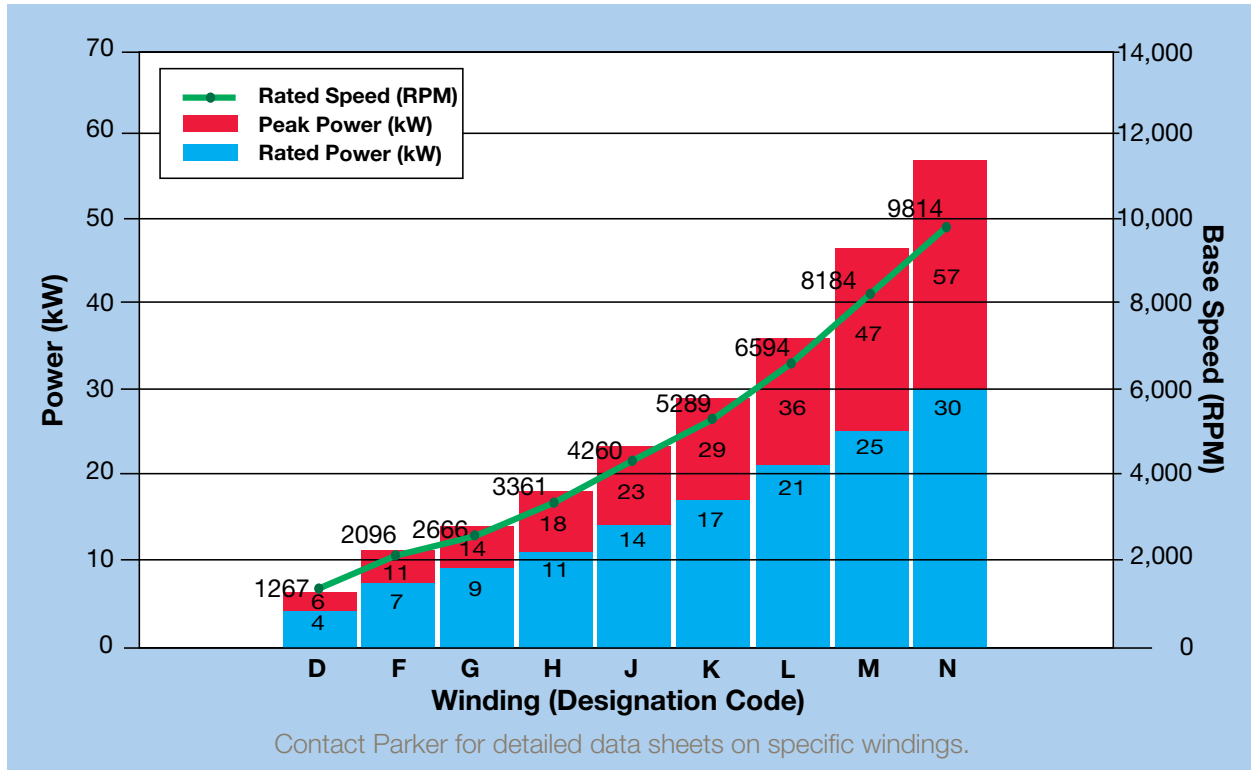

GVM142-100 Dimensions

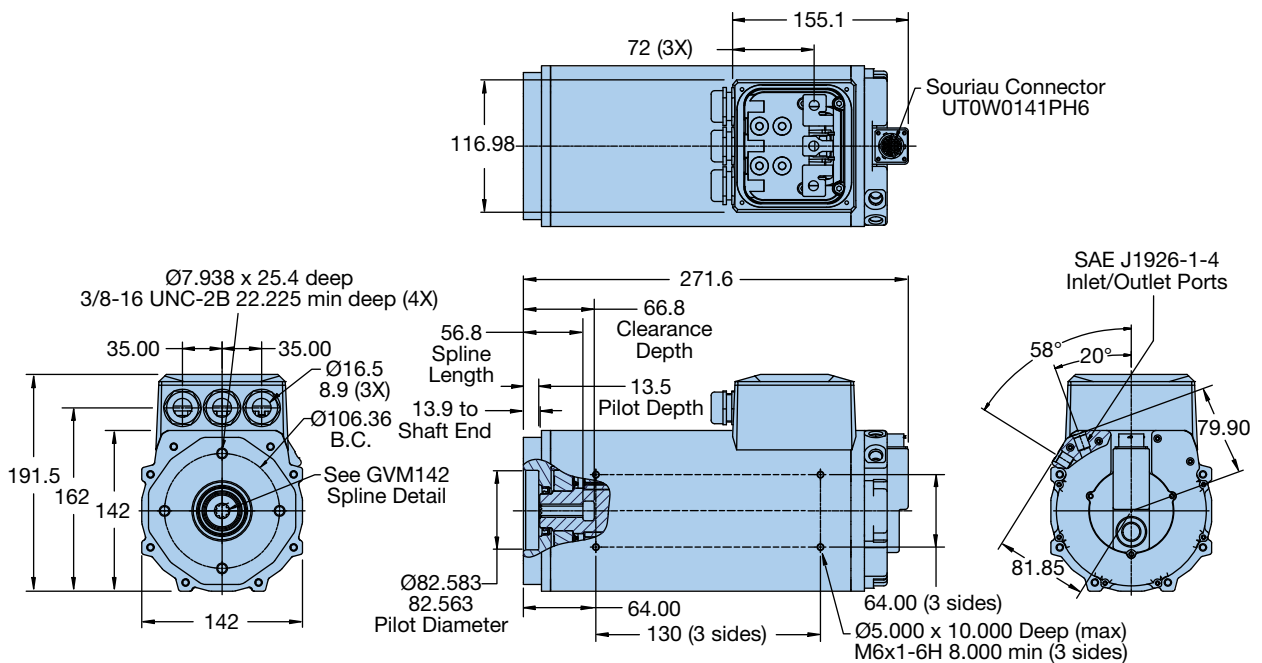

GVM142 Accessory Motors & Generators

GVM142 Feedback and Thermal Connector (all motor sizes)

The Feedback and Thermal Connector option for GVM motors feature a high-quality circular, right-angle, bayonet style connector mounted to the motor body. It is made of zinc coated brass and is rated to IP68/IP69K. It also features a long internal back shell for high vibration resistance meeting SAE J1455 shock/vibe requirements.

The connector provides access to the resolver and thermal signals.

Mating cables are specified and ordered separately.

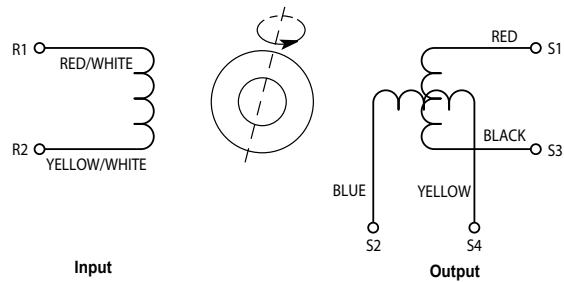
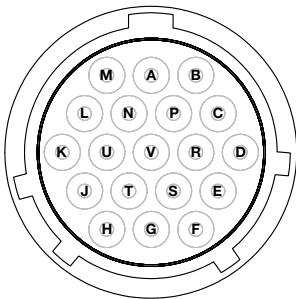

Resolver Feedback and Thermal Connector Pin Assignment

Pin Assignment	Function	Wire Color	From
A	Sin+ S2	Yellow	Resolver
B	Sin- S4	Blue	Resolver
J	Ref+ R1	White	Resolver
K	Ref- R2	Green	Resolver
E	Cos+ S1	Red	Resolver
F	Cos- S3	Black	Resolver
C	Thermistor	Pink	Thermik SNM140 PTC
D	Thermistor	Grey	Thermik SNM140 PTC
G	Thermistor	Red/White (+)	Omega 44008
H	Thermistor	Yellow/White (-)	Omega 44008

Resolver Alignment Specifications (Direction Viewed from Output Shaft)

Parameter	Value
Resolver 0° lock rotor setting	B & C+, A-
Increase feedback angle	Clockwise
Commutation direction (A-B-C)	Clockwise
Resolver poles	6 (3 pole pairs)
Input voltage	AC 7 V _{rms} 10 kHz
Primary	R1-R2
Transformation ratio	0.286 ±10%
Electrical error (mechanical angle)	± 45° maximum
Impedance Z _{ro}	120 ohms ±20%
Impedance Z _{ss} (at theta = 0°)	335 ohms nominal
Dielectric strength (60/50 Hz)	AC 500 V _{rms} 1 minute
Insulation resistance (DC 500 V)	1000 Megohms minimum

GVM142 Feedback Cable

The GVM feedback cable uses environmentally tested and validated cable jacket and connector. It contains all of the low voltage feedback signals. One required per motor.

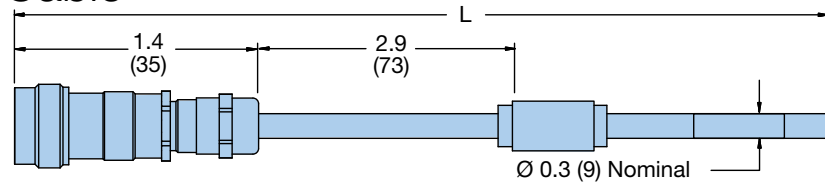

Feedback Cable

Cable Part Number	Description	Length "L" in (m)
170-00506-01	1 m Cable	39.4 (1 m)
170-00506-02	2 m Cable	78.7 (2 m)
170-00506-03	3 m Cable	118.1 (3 m)
170-00506-04	4 m Cable	157.5 (4 m)

GVM142 Phase Power Cable

The GVM power cable uses environmentally tested and validated cable jacket. One cable is required per phase, three per motor. These cables can be field installed and replaced.

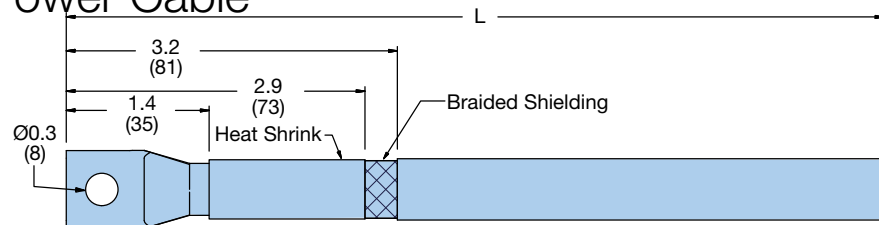

Phase Power Cable

Cable Part Number	Description	Length "L" in (m)
180-00530-01	1 m Cable	43.4 (1.1 m)
180-00530-02	2 m Cable	82.8 (2.1 m)
180-00530-03	3 m Cable	122.1 (3.1 m)
180-00530-04	4 m Cable	161.5 (4.1 m)

GVM142 Cooling

Motor Size	Voltage VDC	Min. Required Flow Rate Gal/Min (L/Min)	Expected Pressure Drop @
			Min. Flow Rate psi (bar)
GVM142-050P	48	0.50 (1.90)	0.09 (0.006)
GVM142-075S	48	0.75 (2.84)	0.25 (0.016)
GVM142-1000W	48	0.85 (3.22)	0.30 (0.020)

Notes:

1. The maximum allowable cooling system pressure is 60 psi.

2. To achieve continuous operation outlined for listed winding, inlet temperature held to 60 °C, 50/50 mix of water/ethylene glycol.

3. Flow rate changes with operating point and winding. Pressure drop changes with flow rate and fluid type.

Contact Parker for specific flow and pressure requirements for the winding and operation point selected.

Recommended Parker Fittings

ID Hose Size in (mm)	Straight Barb Fitting	
	90° Barb Fitting	
0.25 (6.35 mm)	685HB-4-4	—
0.325 (9.525 mm)	685HB-6-4	1695HB-6-4

Please visit www.parkerstore.com to order fittings.

GVM142 Accessory Motors & Generators

GVM142 Spline Detail

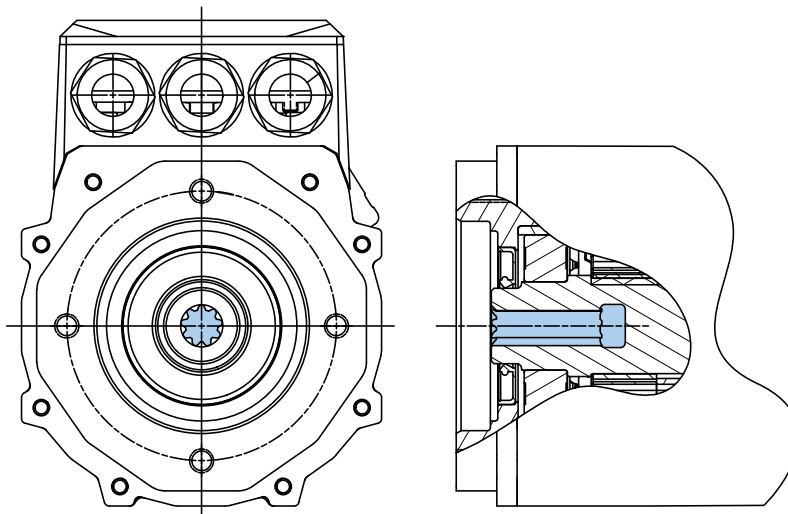

Spline Info – Dimensions in Inches (mm)	P2
GVM142 Motor Frame Size	050 – 100
Involute Spline	ANSI B92.1 Flat Root Class 5
Number of Teeth	9
Spline Pitch	16/32
Pressure Angle	30.0°
Pitch Diameter (ref)	0.5625 in (14.288 mm)
Base Diameter (ref)	0.4871 in (12.373 mm)
Major Diameter	0.6469 in (16.431 mm)
Minor Diameter	0.5000 (12.700 mm)
Form Diameter (max)	0.6290 in (15.977 mm)
Circular Space Width Max Actual	0.1008 in (2.560 mm)
Circular Space Width Min Actual	0.0995 in (2.527 mm)
Pin Diameter (ref)	0.1080 in (2.7432 mm)
Measurement Between Pins (min)	0.3796 in (9.642 mm)/0.3845 in (9.766 mm)

GVM142 Ordering Information

Fill in an order code from each of the numbered fields to create a complete model order code.

Order Example:

①	②	③	④	⑤	⑥	⑦	⑧	⑨	⑩	⑪	⑫
GVM	142	100	M	6	W	R	A	A	P2	1	G

① **Series**
GVM Global Vehicle Motor

② **Frame**
142

③ **Rotor Length**
050 50 mm rotor
075 75 mm rotor
100 100 mm rotor

④ **Winding Letter Code***
* Select based on appropriate performance characteristics, see specific motor size winding charts, pages 4 – 27))

⑤ **Winding Numeric Code**
6

⑥ **Cooling Configuration**
W Water cooling

⑦ **Feedback**
R Resolver
S Sine cosine

⑧ **Thermal Switch**
A PTC

⑨ **Thermal Sensor**
A Omega 44008
B KTY84

⑩ **Output Shaft Configuration**
P2 SAE A 2 Bolt, SAE16-9T Female

⑪ **Power Connection**
1 Terminal box

⑫ **Option**
G Global

Cables Options

Description	Phase Power Cable*	Feedback Cable
1 m Cable	180-00530-01	170-00506-01
2 m Cable	180-00530-02	170-00506-02
3 m Cable	180-00530-03	170-00506-03
4 m Cable	180-00530-04	170-00506-04

* 3 separate phase cables required per GVM Motor

GVM210 Traction Motors & Generators

GVM210-050 Performance @ 350 VDC

Parameter	GVM210-050A	GVM210-050B	GVM210-050C	GVM210-050D
Peak Torque (Nm)	76	77	78	78
Base Speed (RPM)	843	1,374	1,942	2,799
Peak Power (kW)	8	13	18	27
Stall Torque Continuous (Nm)	42	42	43	43
Rated Torque (Nm)	36	36	37	36
Rated Speed (RPM)	1,361	2,245	3,098	4,426
Rated Shaft Output Power (kW)	5	8	12	17
Max Continuous Speed (RPM)	1,966	3,049	4,208	5,924
Stall Current Peak (Amp RMS)	29	45	63.0	89
Stall Current Continuous (Amp RMS)	14	23	32	44
Coolant Temperature (°C)	60	60	60	60
Max Winding Temperature (°C)	180	180	180	180
Winding Temp at Rating (°C)	140	140	140	140
Rotor Inertia (kg-m ²)	0.00988	0.00988	0.00988	0.00988
Motor Weight (kg)	25	25	25	25
Recommended Parker Inverter	MB2	MB2	MB2	MB2

Parameter	GVM210-050F	GVM210-050G	GVM210-050H	GVM210-050J
Peak Torque (Nm)	79	79	79	79
Base Speed (RPM)	3,964	4,933	5,549	6,166
Peak Power (kW)	38	47	53	58
Stall Torque Continuous (Nm)	43	44	44	44
Rated Torque (Nm)	37	36	36	38
Rated Speed (RPM)	5,902	7,223	8,000	8,000
Rated Shaft Output Power (kW)	23	27	30	32
Max Continuous Speed (RPM)	8,000	8,000	8,000	8,000
Stall Current Peak (Amp RMS)	125	156	175	196
Stall Current Continuous (Amp RMS)	62	78	88	98
Coolant Temperature (°C)	60	60	60	60
Max Winding Temperature (°C)	180	180	180	180
Winding Temp at Rating (°C)	140	140	140	140
Rotor Inertia (kg-m ²)	0.00988	0.00988	0.00988	0.00988
Motor Weight (kg)	25	25	25	25
Recommended Parker Inverter	MB2	MB2	MA3	MA3

GVM210-050 Winding Performance & Selection @ 350 VDC

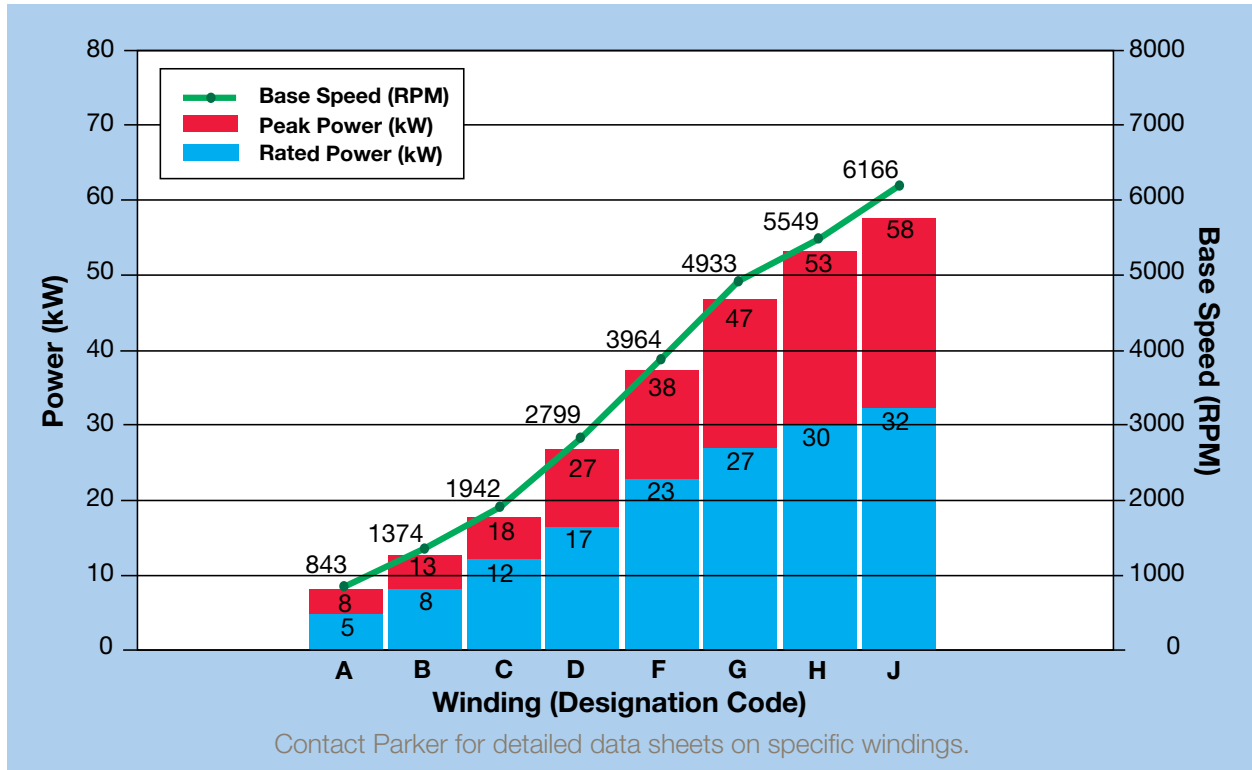

GVM210-050 Dimensions

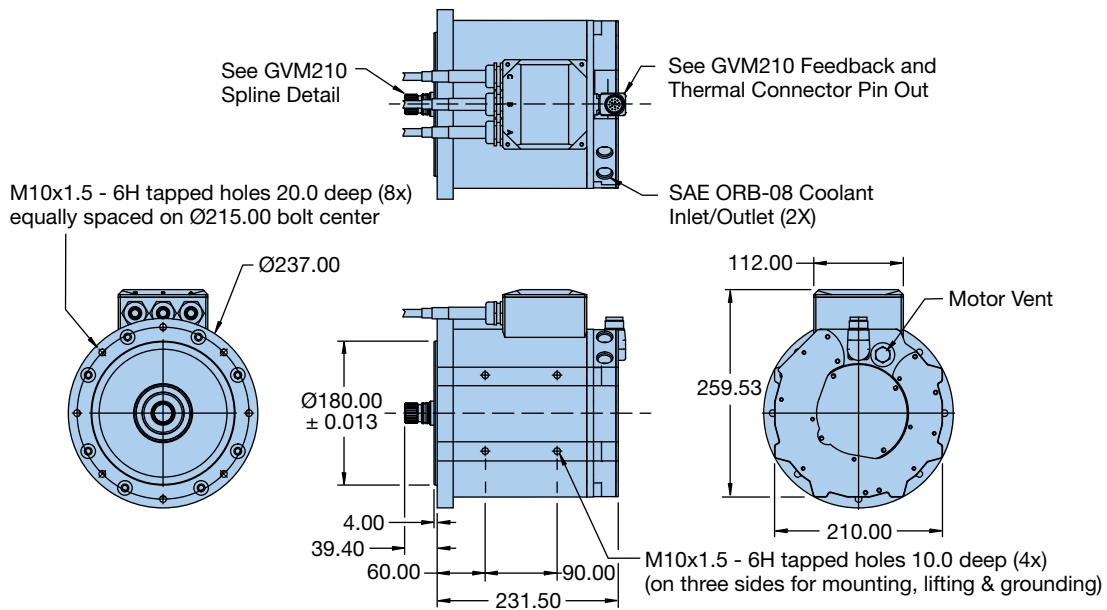

GVM210 Traction Motors & Generators

GVM210-050 Performance @ 650 VDC

Parameter	GVM210-050A	GVM210-050B	GVM210-050C
Peak Torque (Nm)	76	77	78
Base Speed (RPM)	1,685	2,676	3,779
Peak Power (kW)	16	25	35
Stall Torque Continuous (Nm)	42	42	43
Rated Torque (Nm)	36	35	37
Rated Speed (RPM)	2,648	4,232	5,582
Rated Shaft Output Power (kW)	10	16	21
Max Continuous Speed (RPM)	3,652	5,663	7,815
Stall Current Peak (Amp RMS)	29	45	63
Stall Current Continuous (Amp RMS)	14	23	32
Coolant Temperature (°C)	60	60	60
Max Winding Temperature (°C)	180	180	180
Winding Temp at Rating (°C)	140	140	140
Rotor Inertia (kg-m ²)	0.00988	0.00988	0.00988
Motor Weight (kg)	25	25	25
Recommended Parker Inverter	MB2	MB2	MB2

Parameter	GVM210-050D	GVM210-050F
Peak Torque (Nm)	78	79
Base Speed (RPM)	5,373	7,575
Peak Power (kW)	50	63
Stall Torque Continuous (Nm)	43	43
Rated Torque (Nm)	36	38
Rated Speed (RPM)	7,663	8,000
Rated Shaft Output Power (kW)	29	31
Max Continuous Speed (RPM)	8,000	8,000
Stall Current Peak (Amp RMS)	89	125
Stall Current Continuous (Amp RMS)	44	62
Coolant Temperature (°C)	60	60
Max Winding Temperature (°C)	180	180
Winding Temp at Rating (°C)	140	140
Rotor Inertia (kg-m ²)	0.00988	0.00988
Motor Weight (kg)	25	25
Recommended Parker Inverter	MB2	MB2

GVM210-050 Winding Performance & Selection @ 650 VDC

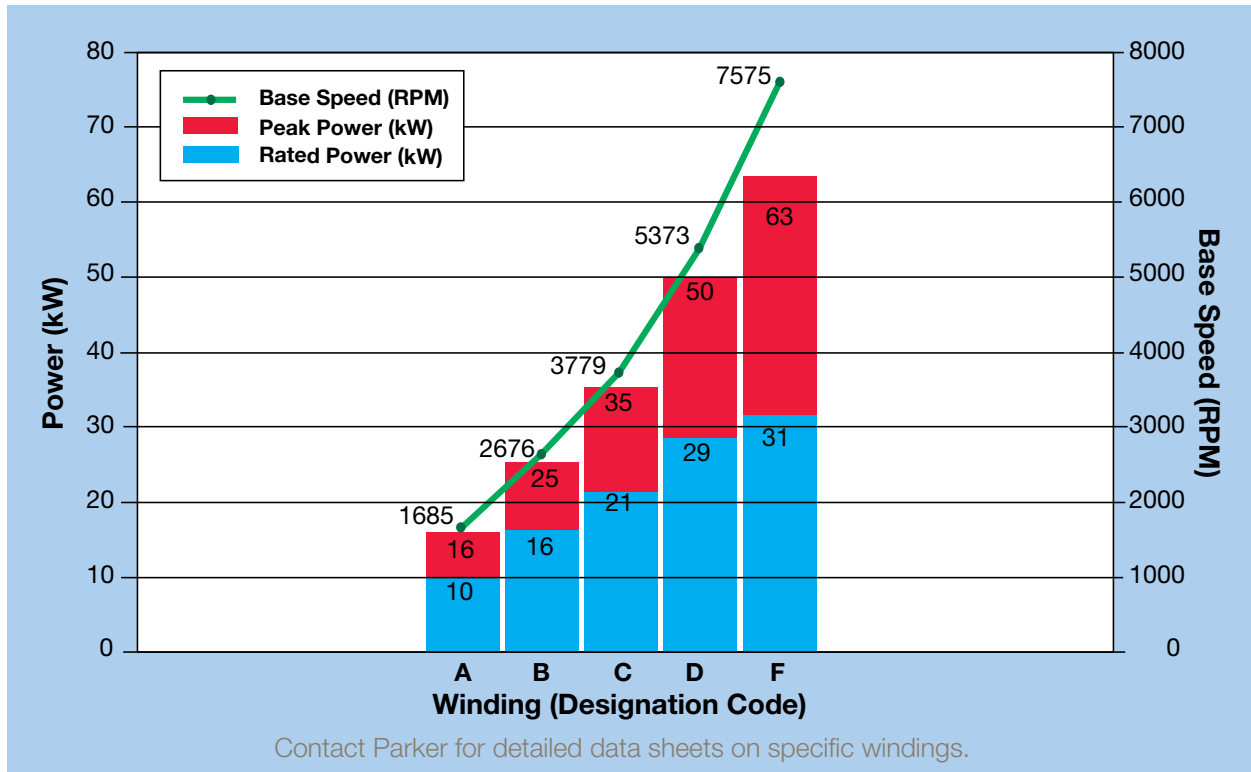

GVM210-050 Dimensions

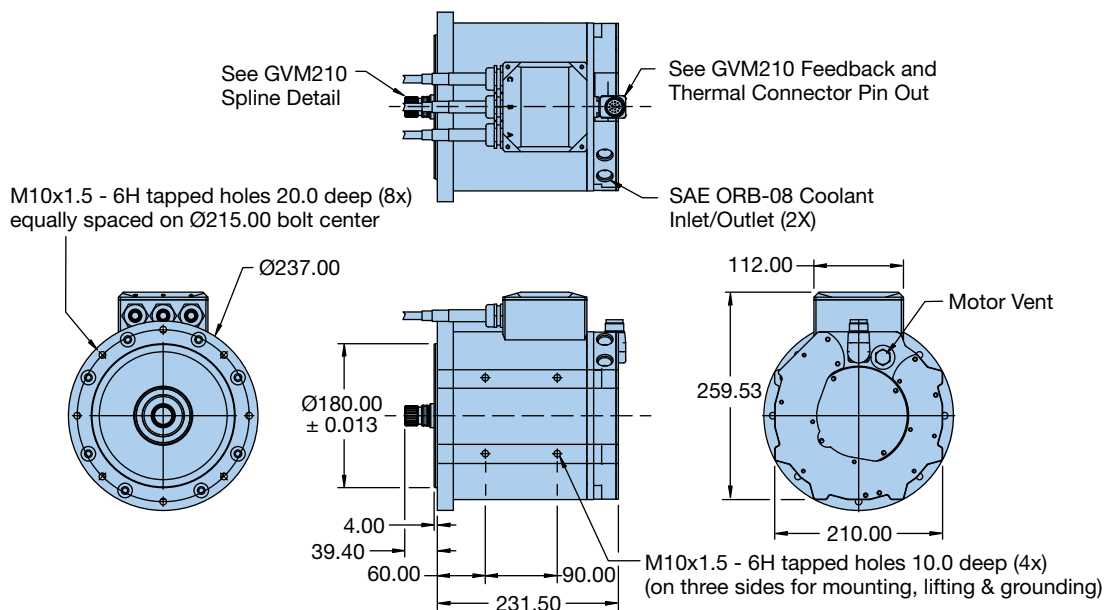

GVM210 Traction Motors & Generators

GVM210-100 Performance @ 350 VDC

Parameter	GVM210-100D	GVM210-100F	GVM210-100G	GVM210-100H	GVM210-100J	GVM210-100K
Peak Torque (Nm)	165	166	167	167	167	167
Base Speed (RPM)	1,303	1,856	2,304	2,652	2,943	3,305
Peak Power (kW)	26	37	47	53	59	66
Stall Torque Continuous (Nm)	93	94	94	94	95	95
Rated Torque (Nm)	77	77	78	78	78	78
Rated Speed (RPM)	2,248	3,168	3,878	4,293	4,764	5,272
Rated Shaft Output Power (kW)	18	25	32	35	39	43
Max Continuous Speed (RPM)	2,964	4,119	5,114	5,746	6,375	7,160
Stall Current Peak (Amp RMS)	97	135	169	190	212	238
Stall Current Continuous (Amp RMS)	48	68	85	95	106	119
Coolant Temperature (°C)	60	60	60	60	60	60
Max Winding Temperature (°C)	180	180	180	180	180	180
Winding Temp at Rating (°C)	140	140	140	140	140	140
Rotor Inertia (kg-m ²)	0.01904	0.01904	0.01904	0.01904	0.01904	0.01904
Motor Weight (kg)	35	35	35	35	35	35
Recommended Parker Inverter	MB2	MB2	MA3	MA3	MA3	MA3

Parameter	GVM210-100L	GVM210-100M	GVM210-100N	GVM210-100P	GVM210-100Q
Peak Torque (Nm)	167	167	166	168	168
Base Speed (RPM)	3,788	4,228	4,845	5,373	5,902
Peak Power (kW)	76	85	97	106	117
Stall Torque Continuous (Nm)	94	94	94	95	95
Rated Torque (Nm)	76	77	77	75	79
Rated Speed (RPM)	5,990	6,518	7,135	7,840	8,000
Rated Shaft Output Power (kW)	48	53	57	62	65
Max Continuous Speed (RPM)	8,000	8,000	8,000	8,000	8,000
Stall Current Peak (Amp RMS)	270	302	341	378	422
Stall Current Continuous (Amp RMS)	135	151	170	189	211
Coolant Temperature (°C)	60	60	60	60	60
Max Winding Temperature (°C)	180	180	180	180	180
Winding Temp at Rating (°C)	140	140	140	140	140
Rotor Inertia (kg-m ²)	0.01904	0.01904	0.01904	0.01904	0.01904
Motor Weight (kg)	35	35	35	35	35
Recommended Parker Inverter	MA3	MA3	MA3	MA3	MA3

GVM210-100 Winding Performance & Selection @ 350 VDC

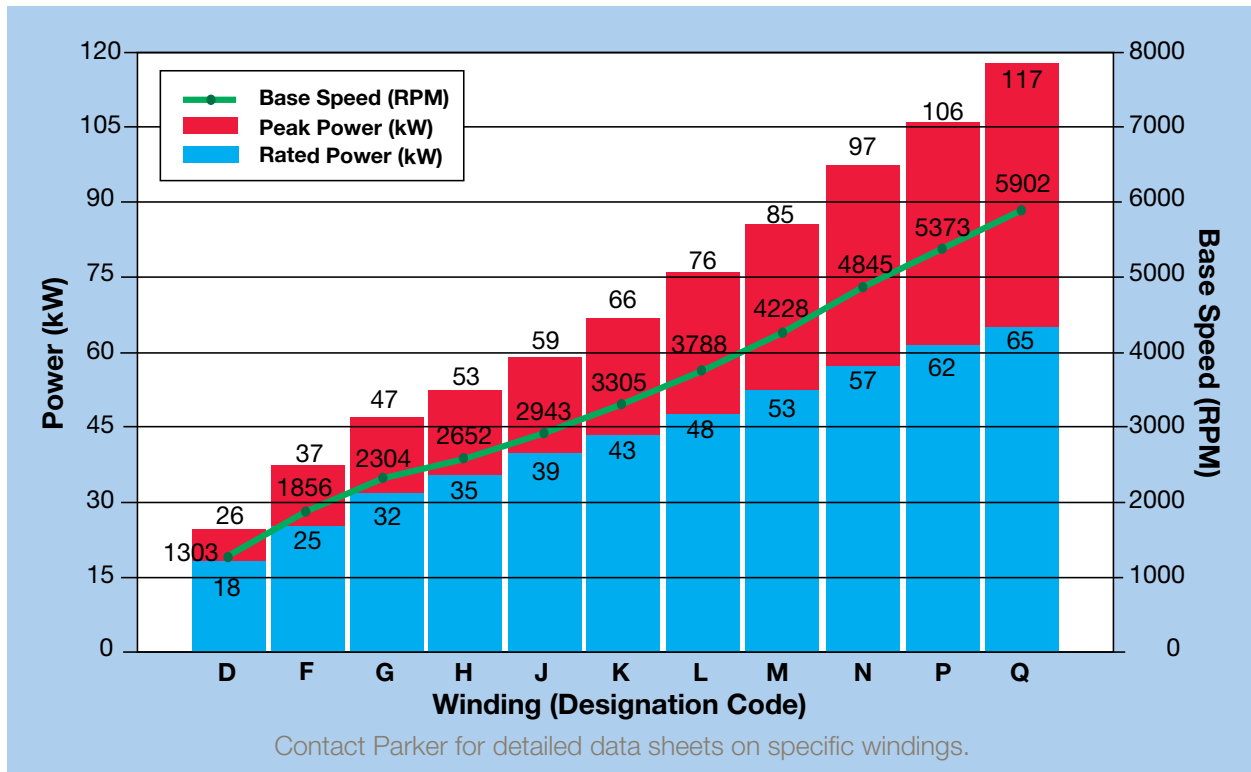

GVM210-100 Dimensions

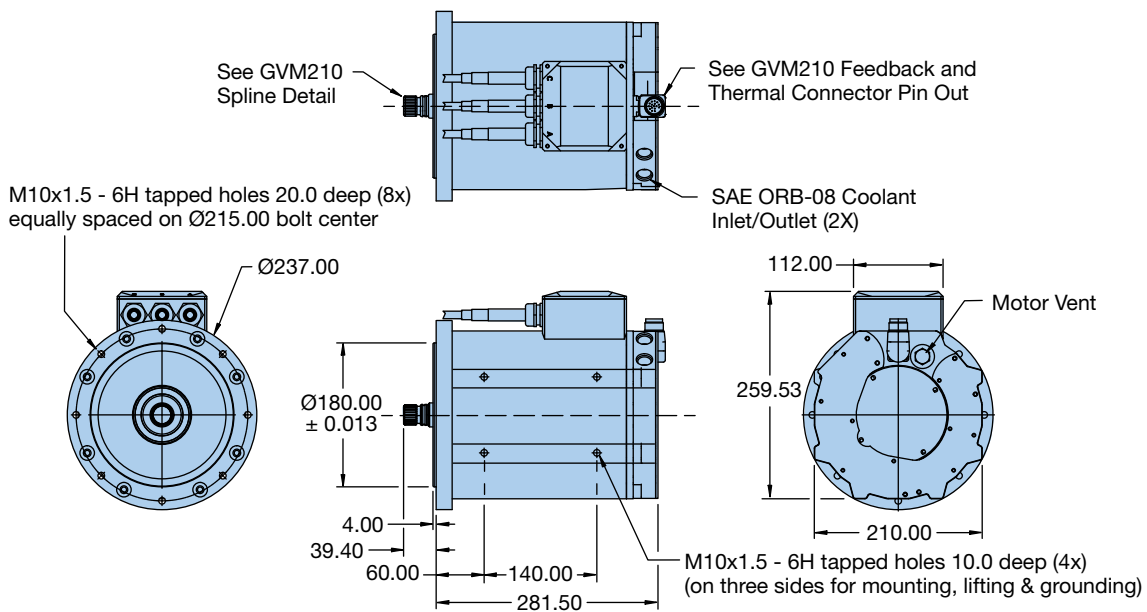

GVM210 Traction Motors & Generators

GVM210-100 Performance @ 650 VDC

Parameter	GVM210-100B	GVM210-100C	GVM210-100D	GVM210-100F
Peak Torque (Nm)	163	165	165	166
Base Speed (RPM)	1,246	1,762	2,541	3,530
Peak Power (kW)	25	35	50	71
Stall Torque Continuous (Nm)	91	92	93	93
Rated Torque (Nm)	77	77	77	78
Rated Speed (RPM)	2,118	2,965	4,114	5,547
Rated Shaft Output Power (kW)	17	24	33	45
Max Continuous Speed (RPM)	2,834	3,911	5,505	7,649
Stall Current Peak (Amp RMS)	49	68	97	135
Stall Current Continuous (Amp RMS)	24	34	48	68
Coolant Temperature (°C)	60	60	60	60
Max Winding Temperature (°C)	180	180	180	180
Winding Temp at Rating (°C)	140	140	140	140
Rotor Inertia (kg-m ²)	0.01904	0.01904	0.01904	0.01904
Motor Weight (kg)	35	35	35	35
Recommended Parker Inverter	MB2	MB2	MB2	MB2

Parameter	GVM210-100G	GVM210-100H	GVM210-100J
Peak Torque (Nm)	167	167	167
Base Speed (RPM)	4,404	5,021	5,549
Peak Power (kW)	89	100	110
Stall Torque Continuous (Nm)	94	94	95
Rated Torque (Nm)	77	77	76
Rated Speed (RPM)	6,694	7,311	8,000
Rated Shaft Output Power (kW)	54	59	63
Max Continuous Speed (RPM)	8,000	8,000	8,000
Stall Current Peak (Amp RMS)	169	190	212
Stall Current Continuous (Amp RMS)	85	95	106
Coolant Temperature (°C)	60	60	60
Max Winding Temperature (°C)	180	180	180
Winding Temp at Rating (°C)	140	140	140
Rotor Inertia (kg-m ²)	0.01904	0.01904	0.01904
Motor Weight (kg)	35	35	35
Recommended Parker Inverter	MA3	MA3	MA3

GVM210-100 Winding Performance & Selection @ 650 VDC

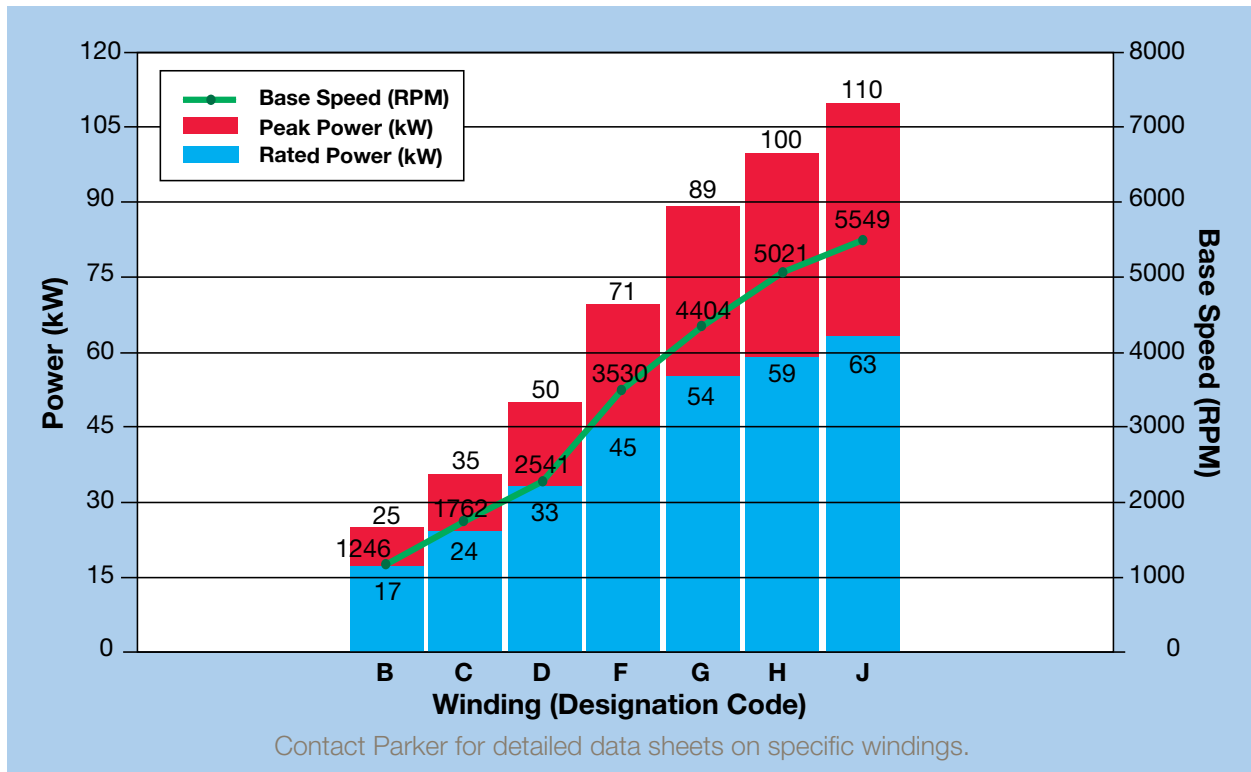

GVM210-100 Dimensions

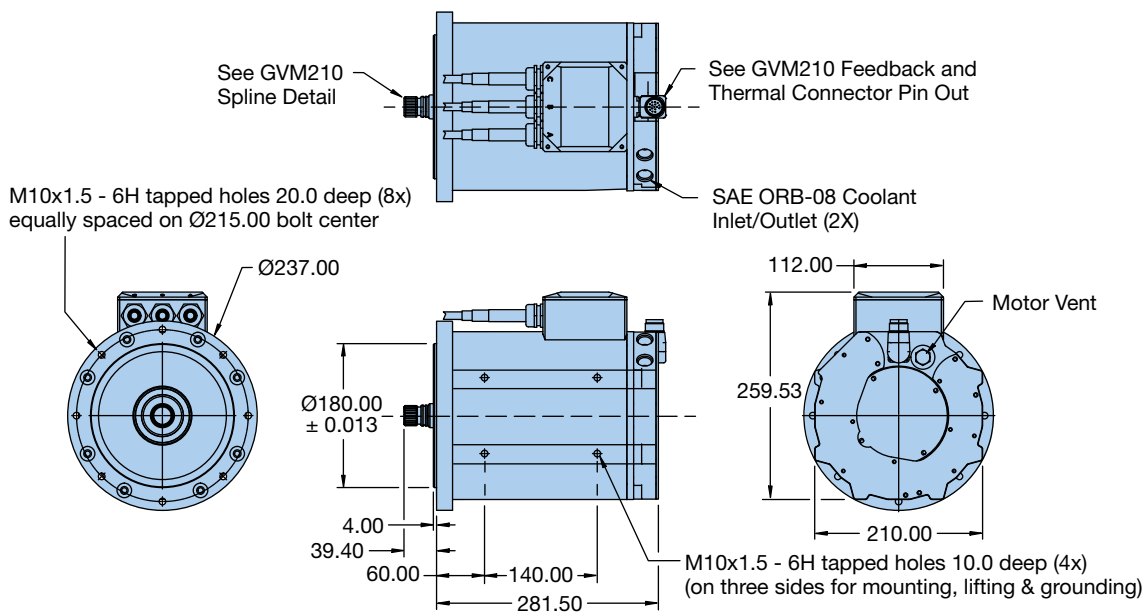

GVM210 Traction Motors & Generators

GVM210-150 Performance @ 350 VDC

Parameter	GVM210-150F	GVM210-150G	GVM210-150H	GVM210-150J	GVM210-150K	GVM210-150L
Peak Torque (Nm)	254	256	256	257	257	257
Base Speed (RPM)	1,207	1,499	1,684	1,915	2,151	2,452
Peak Power (kW)	36	46	52	58	66	75
Stall Torque Continuous (Nm)	145	146	146	146	146	145
Rated Torque (Nm)	113	120	119	120	119	121
Rated Speed (RPM)	2,203	2,623	2,946	3,269	3,672	4,067
Rated Shaft Output Power (kW)	26	33	37	41	46	52
Max Continuous Speed (RPM)	2,746	3,409	3,830	4,250	4,773	5,443
Stall Current Peak (Amp RMS)	140	175	196	219	246	279
Stall Current Continuous (Amp RMS)	70	87	98	110	123	139
Coolant Temperature (°C)	60	60	60	60	60	60
Max Winding Temperature (°C)	180	180	180	180	180	180
Winding Temp at Rating (°C)	140	140	140	140	140	140
Rotor Inertia (kg-m ²)	0.02825	0.02825	0.02825	0.02825	0.02825	0.02825
Motor Weight (kg)	46	46	46	46	46	46
Recommended Parker Inverter	MB2	MA3	MA3	MA3	MA3	MA3

Parameter	GVM210-150M	GVM210-150N	GVM210-150P	GVM210-150Q	GVM210-150R	GVM210-150S
Peak Torque (Nm)	256	255	257	258	258	257
Base Speed (RPM)	2,741	3,182	3,409	3,788	4,316	4,933
Peak Power (kW)	84	96	106	117	132	150
Stall Torque Continuous (Nm)	146	145	147	147	148	147
Rated Torque (Nm)	118	121	119	121	120	117
Rated Speed (RPM)	4,613	5,000	5,571	5,990	6,606	7,311
Rated Shaft Output Power (kW)	57	63	69	76	83	90
Max Continuous Speed (RPM)	6,083	6,894	7,567	8,000	8,000	8,000
Stall Current Peak (Amp RMS)	312	352	391	436	489	553
Stall Current Continuous (Amp RMS)	156	176	195	218	244	276
Coolant Temperature (°C)	60	60	60	60	60	60
Max Winding Temperature (°C)	180	180	180	180	180	180
Winding Temp at Rating (°C)	140	140	140	140	140	140
Rotor Inertia (kg-m ²)	0.02825	0.02825	0.02825	0.02825	0.02825	0.02825
Motor Weight (kg)	46	46	46	46	46	46
Recommended Parker Inverter	MA3	MA3	MA3	Contact Factory	Contact Factory	Contact Factory

GVM210-150 Winding Performance & Selection @ 350 VDC

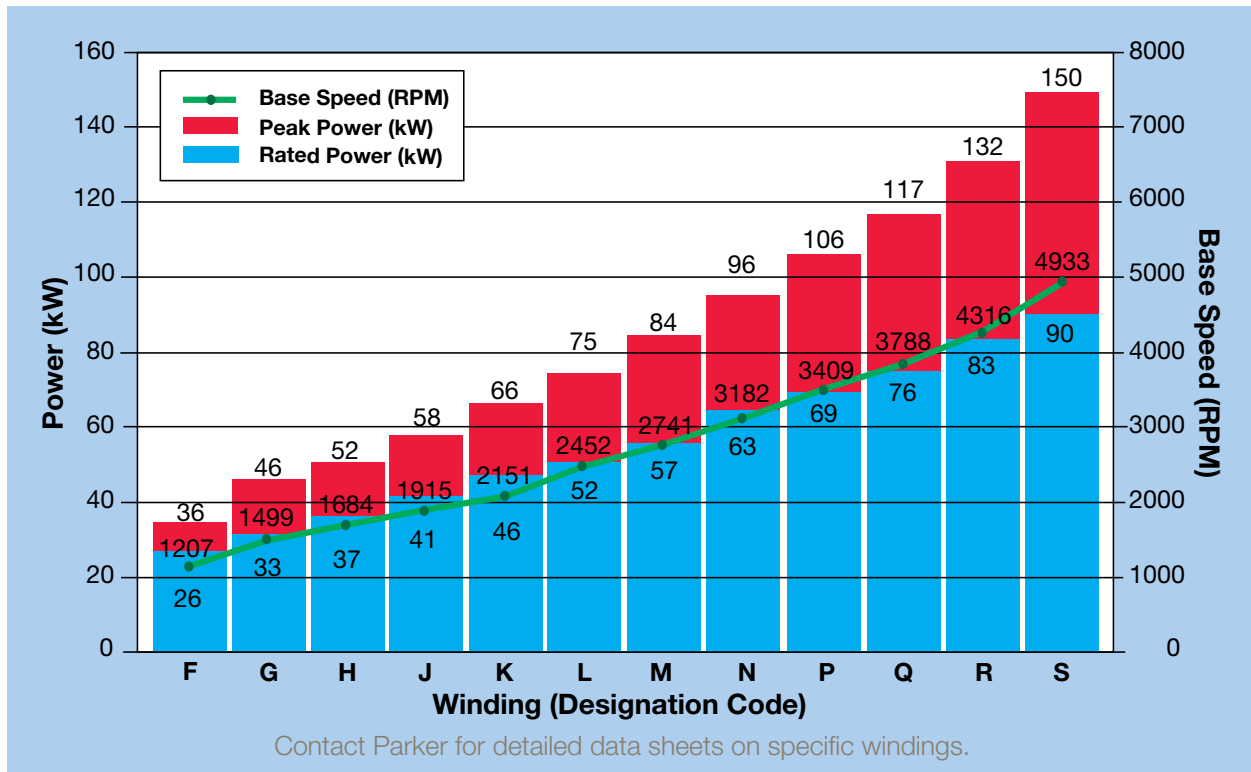

GVM210-150 Dimensions

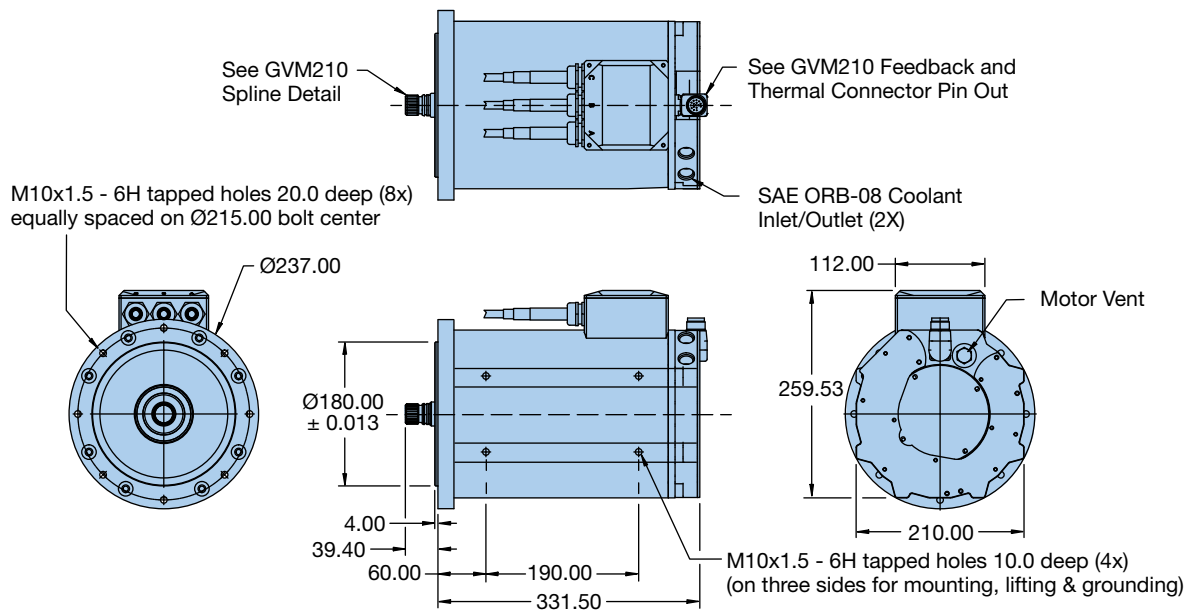

GVM210 Traction Motors & Generators

GVM210-150 Performance @ 650 VDC

Parameter	GVM210-150C	GVM210-150D	GVM210-150F	GVM210-150G	GVM210-150H
Peak Torque (Nm)	252	253	254	256	256
Base Speed (RPM)	1,146	1,654	2,297	2,853	3,283
Peak Power (kW)	34	50	70	88	99
Stall Torque Continuous (Nm)	143	143	145	146	146
Rated Torque (Nm)	117	114	121	121	119
Rated Speed (RPM)	2,006	2,904	3,810	4,662	5,237
Rated Shaft Output Power (kW)	25	35	48	59	65
Max Continuous Speed (RPM)	2,607	3,670	5,099	6,332	7,113
Stall Current Peak (Amp RMS)	71	100	140	175	196
Stall Current Continuous (Amp RMS)	35	50	70	87	98
Coolant Temperature (°C)	60	60	60	60	60
Max Winding Temperature (°C)	180	180	180	180	180
Winding Temp at Rating (°C)	140	140	140	140	140
Rotor Inertia (kg-m ²)	0.02825	0.02825	0.02825	0.02825	0.02825
Motor Weight (kg)	45	45	45	45	45
Recommended Parker Inverter	MB2	MB2	MB2	MA3	MA3

Parameter	GVM210-150J	GVM210-150K	GVM210-150L	GVM210-150M	GVM210-150N
Peak Torque (Nm)	257	257	255	256	255
Base Speed (RPM)	3,643	4,052	4,669	5,285	5,990
Peak Power (kW)	110	124	142	159	179
Stall Torque Continuous (Nm)	146	146	145	146	145
Rated Torque (Nm)	122	120	118	116	117
Rated Speed (RPM)	5,638	6,254	6,959	7,575	8,000
Rated Shaft Output Power (kW)	72	79	86	92	97
Max Continuous Speed (RPM)	7,893	8,000	8,000	8,000	8,000
Stall Current Peak (Amp RMS)	219	246	279	312	352
Stall Current Continuous (Amp RMS)	110	123	139	156	176
Coolant Temperature (°C)	60	60	60	60	60
Max Winding Temperature (°C)	180	180	180	180	180
Winding Temp at Rating (°C)	140	140	140	140	140
Rotor Inertia (kg-m ²)	0.02825	0.02825	0.02825	0.02825	0.02825
Motor Weight (kg)	45	45	45	45	45
Recommended Parker Inverter	MA3	MA3	MA3	MA3	MA3

GVM210-150 Winding Performance & Selection @ 650 VDC

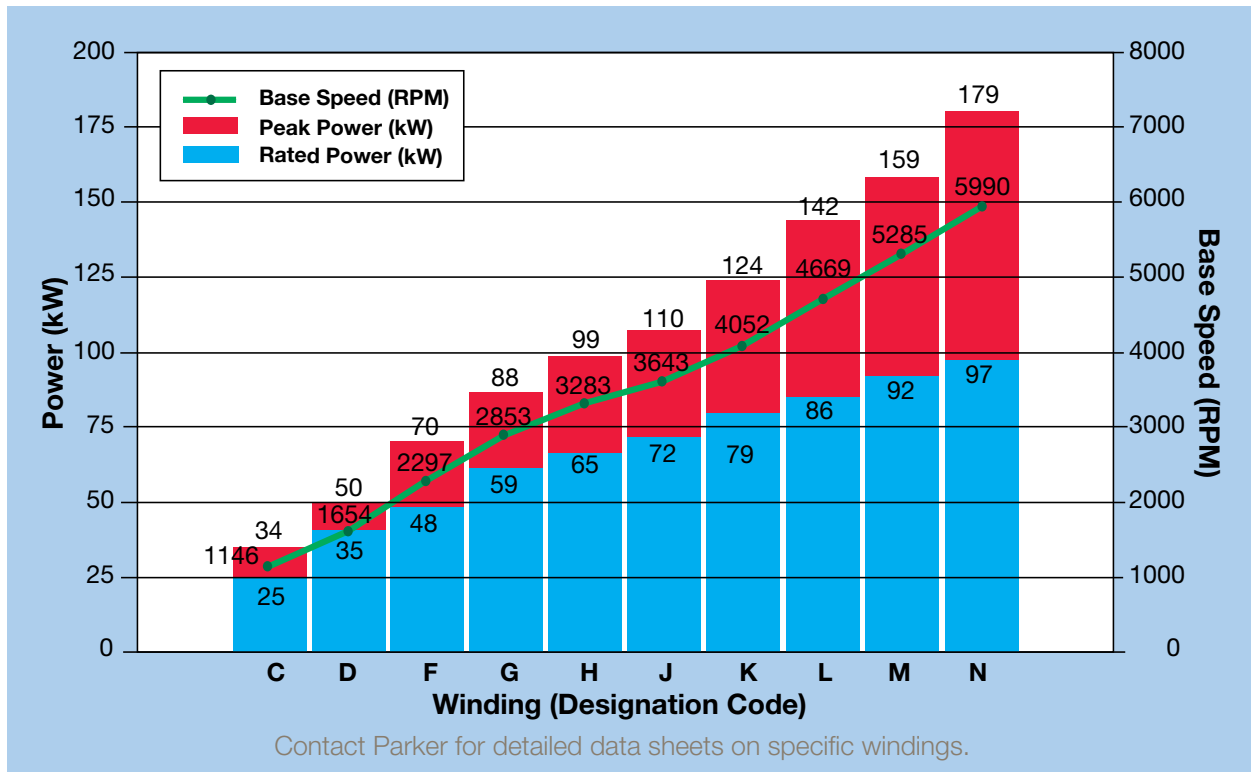

GVM210-150 Dimensions

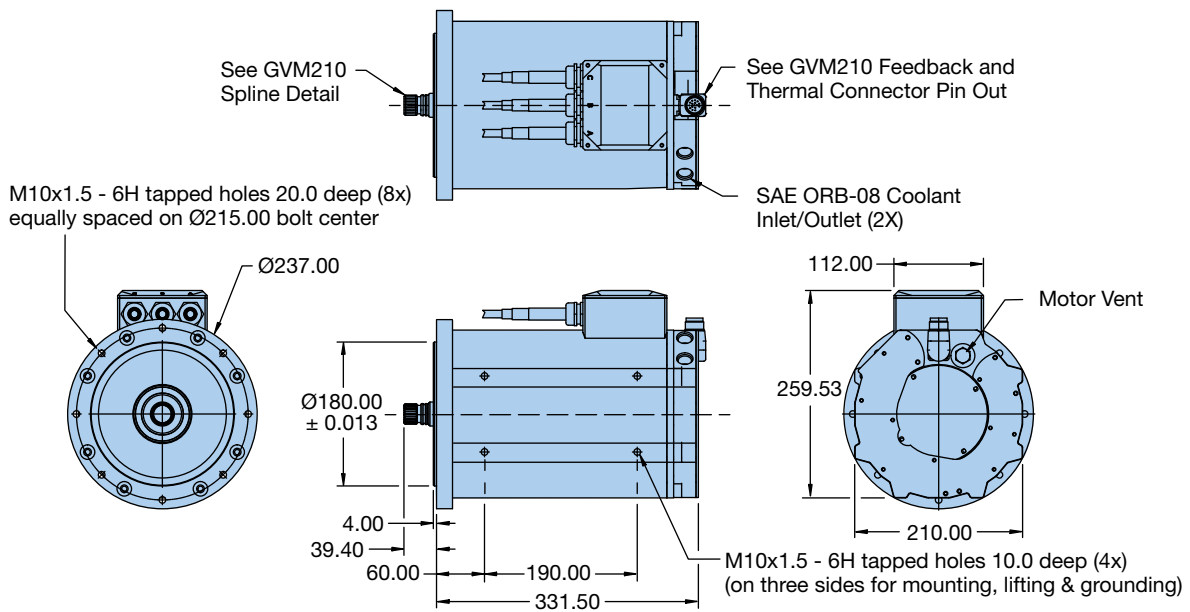

GVM210 Traction Motors & Generators

GVM210-200 Performance @ 350 VDC

Parameter	GVM210-200H	GVM210-200J	GVM210-200K	GVM210-200L	GVM210-200M	GVM210-200N
Peak Torque (Nm)	312	313	313	311	312	311
Base Speed (RPM)	1,327	1,507	1,692	1,930	2,157	2,502
Peak Power (kW)	51	57	64	73	83	94
Stall Torque Continuous (Nm)	172	173	173	172	172	171
Rated Torque (Nm)	146	149	146	147	144	146
Rated Speed (RPM)	2,148	2,348	2,676	3,007	3,411	3,752
Rated Shaft Output Power (kW)	33	37	41	46	51	57
Max Continuous Speed (RPM)	2,874	3,189	3,582	4,084	4,565	5,174
Stall Current Peak (Amp RMS)	173	193	217	245	275	310
Stall Current Continuous (Amp RMS)	86	96	108	123	137	155
Coolant Temperature (°C)	60	60	60	60	60	60
Max Winding Temperature (°C)	180	180	180	180	180	180
Winding Temp at Rating (°C)	140	140	140	140	140	140
Rotor Inertia (kg-m ²)	0.03737	0.03737	0.03737	0.03737	0.03737	0.03737
Motor Weight (kg)	56	56	56	56	56	56
Recommended Parker Inverter	MA3	MA3	MA3	MA3	MA3	MA3

Parameter	GVM210-200P	GVM210-200R	GVM210-200S	GVM210-200T	GVM210-200V
Peak Torque (Nm)	314	315	314	310	314
Base Speed (RPM)	2,746	3,411	3,876	4,580	5,021
Peak Power (kW)	104	130	148	170	186
Stall Torque Continuous (Nm)	173	174	173	170	173
Rated Torque (Nm)	146	147	144	137	136
Rated Speed (RPM)	4,118	4,962	5,549	6,342	6,783
Rated Shaft Output Power (kW)	63	76	84	91	97
Max Continuous Speed (RPM)	5,678	7,055	8,000	8,000	8,000
Stall Current Peak (Amp RMS)	344	431	487	556	614
Stall Current Continuous (Amp RMS)	172	215	243	278	307
Coolant Temperature (°C)	60	60	60	60	60
Max Winding Temperature (°C)	180	180	180	180	180
Winding Temp at Rating (°C)	140	140	140	140	140
Rotor Inertia (kg-m ²)	0.03737	0.03737	0.03737	0.03737	0.03737
Motor Weight (kg)	56	56	56	56	56
Recommended Parker Inverter	MA3	Contact Factory	Contact Factory	Contact Factory	Contact Factory

GVM210-200 Winding Performance & Selection @ 350 VDC

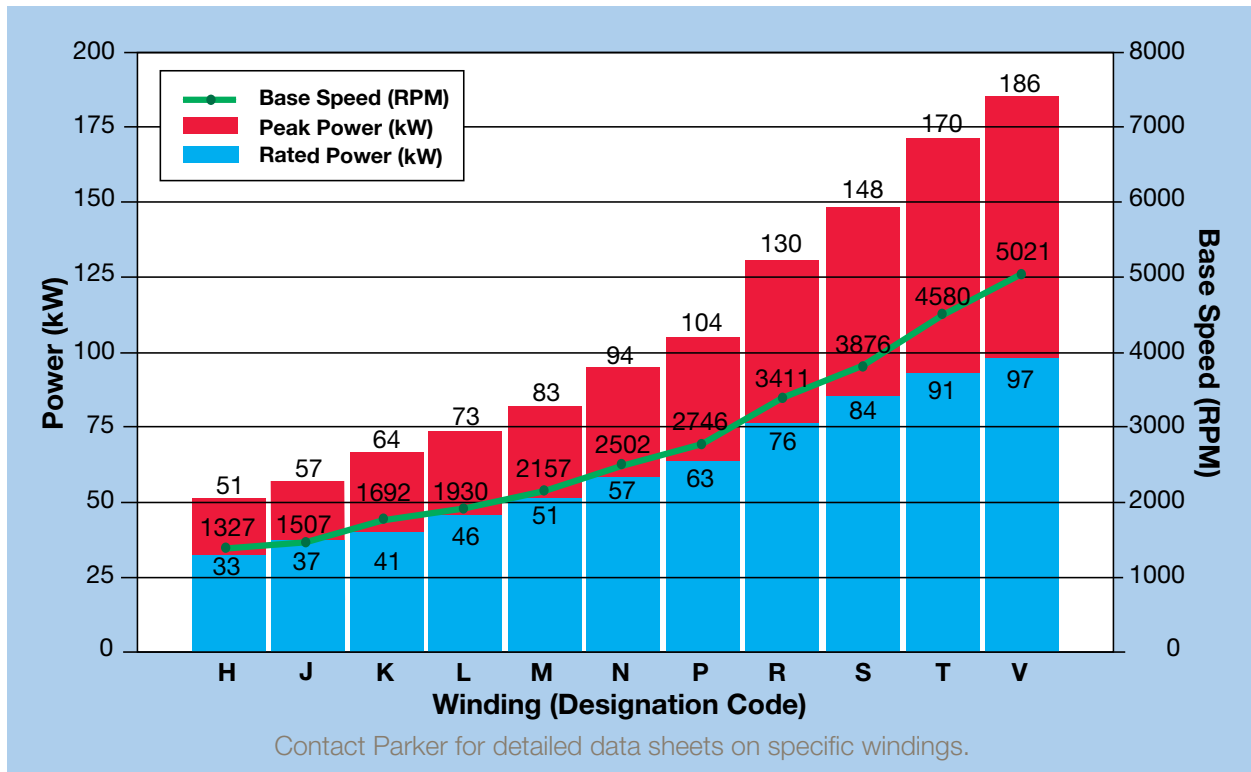

GVM210-200 Dimensions

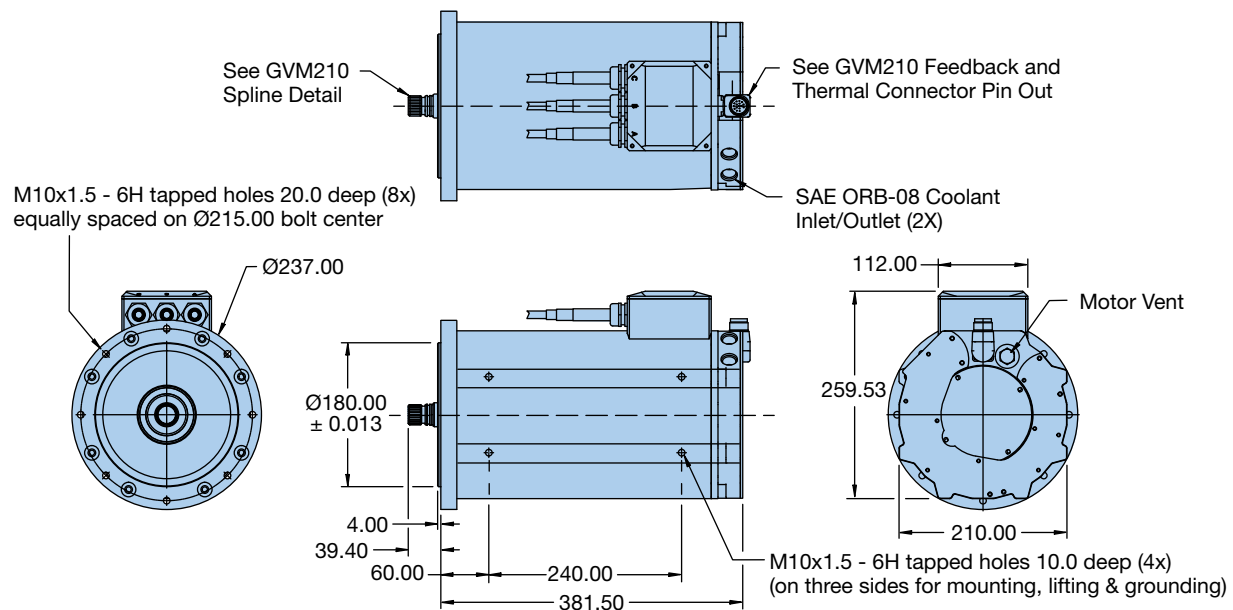

GVM210 Traction Motors & Generators

GVM210-200 Performance @ 650 VDC

Parameter	GVM210-200D	GVM210-200F	GVM210-200G	GVM210-200H	GVM210-200J	GVM210-200K
Peak Torque (Nm)	308	310	312	312	313	313
Base Speed (RPM)	1,271	1,808	2,297	2,581	2,864	3,216
Peak Power (kW)	48	68	86	97	108	122
Stall Torque Continuous (Nm)	169	171	172	172	173	173
Rated Torque (Nm)	143	144	143	146	145	143
Rated Speed (RPM)	2,058	2,859	3,550	3,871	4,296	4,824
Rated Shaft Output Power (kW)	31	43	53	59	65	72
Max Continuous Speed (RPM)	2,754	3,826	4,751	5,338	5,923	6,652
Stall Current Peak (Amp RMS)	88	123	154	173	193	217
Stall Current Continuous (Amp RMS)	44	62	77	86	96	108
Coolant Temperature (°C)	60	60	60	60	60	60
Max Winding Temperature (°C)	180	180	180	180	180	180
Winding Temp at Rating (°C)	140	140	140	140	140	140
Rotor Inertia (kg-m ²)	0.03737	0.03737	0.03737	0.03737	0.03737	0.03737
Motor Weight (kg)	56	56	56	56	56	56
Recommended Parker Inverter	MB2	MB2	MB2	MA3	MA3	MA3

Parameter	GVM210-200L	GVM210-200M	GVM210-200N	GVM210-200P	GVM210-200Q
Peak Torque (Nm)	311	312	311	314	315
Base Speed (RPM)	3,668	4,140	4,757	5,197	5,814
Peak Power (kW)	139	156	177	194	214
Stall Torque Continuous (Nm)	172	172	171	173	174
Rated Torque (Nm)	144	139	138	136	130
Rated Speed (RPM)	5,251	5,902	6,430	6,959	7,575
Rated Shaft Output Power (kW)	79	86	93	99	103
Max Continuous Speed (RPM)	7,585	8,000	8,000	8,000	8,000
Stall Current Peak (Amp RMS)	245	275	310	344	384
Stall Current Continuous (Amp RMS)	123	137	155	172	192
Coolant Temperature (°C)	60	60	60	60	60
Max Winding Temperature (°C)	180	180	180	180	180
Winding Temp at Rating (°C)	140	140	140	140	140
Rotor Inertia (kg-m ²)	0.03737	0.03737	0.03737	0.03737	0.03737
Motor Weight (kg)	56	56	56	56	56
Recommended Parker Inverter	MA3	MA3	MA3	MA3	MA3

GVM210-200 Winding Performance & Selection @ 650 VDC

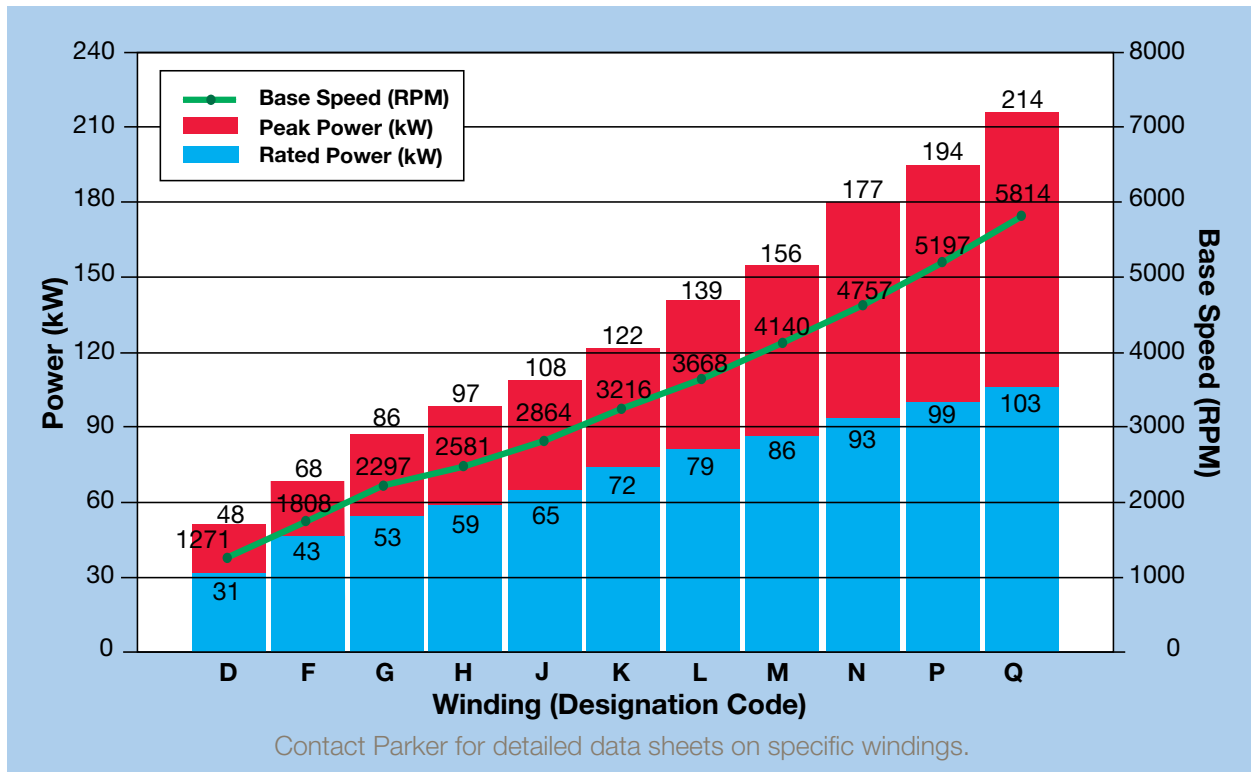

GVM210-200 Dimensions

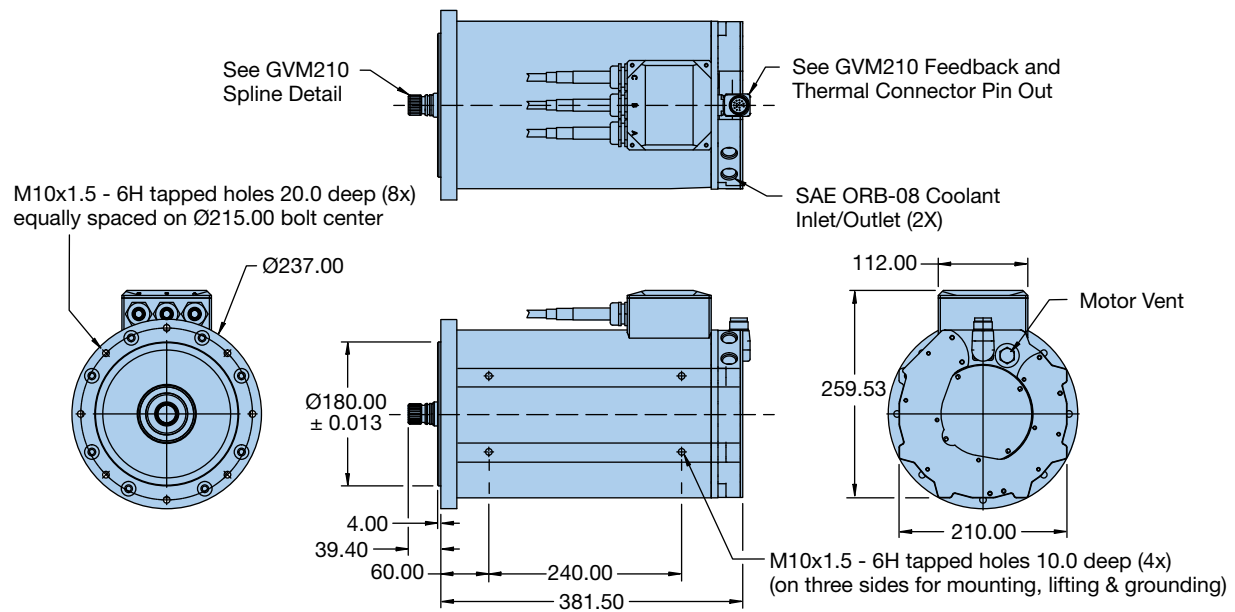

GVM210 Traction Motors & Generators

GVM210-300 Performance @ 350 VDC

Parameter	GVM210-300K	GVM210-300L	GVM210-300M	GVM210-300N	GVM210-300P
Peak Torque (Nm)	524	521	522	521	524
Base Speed (RPM)	1,023	1,166	1,303	1,515	1,663
Peak Power (kW)	63	73	82	94	103
Stall Torque Continuous (Nm)	301	299	300	299	302
Rated Torque (Nm)	236	235	243	238	244
Rated Speed (RPM)	1,914	2,183	2,373	2,727	2,952
Rated Shaft Output Power (kW)	47	54	60	68	75
Max Continuous Speed (RPM)	2,386	2,721	3,041	3,447	3,783
Stall Current Peak (Amp RMS)	254	287	322	363	403
Stall Current Continuous (Amp RMS)	127	144	161	182	202
Coolant Temperature (°C)	60	60	60	60	60
Max Winding Temperature (°C)	180	180	180	180	180
Winding Temp at Rating (°C)	140	140	140	140	140
Rotor Inertia (kg-m ²)	0.05584	0.05584	0.05584	0.05584	0.05584
Motor Weight (kg)	77	77	77	77	77
Recommended Parker Inverter	MA3	MA3	MA3	MA3	MA3

Parameter	GVM210-300Q	GVM210-300R	GVM210-300S	GVM210-300T
Peak Torque (Nm)	527	527	525	520
Base Speed (RPM)	1,843	2,066	2,351	2,795
Peak Power (kW)	115	130	149	173
Stall Torque Continuous (Nm)	304	304	292	298
Rated Torque (Nm)	241	246	249	238
Rated Speed (RPM)	3,317	3,616	3,997	4,704
Rated Shaft Output Power (kW)	84	93	104	117
Max Continuous Speed (RPM)	4,192	4,700	5,349	6,204
Stall Current Peak (Amp RMS)	450	505	571	651
Stall Current Continuous (Amp RMS)	225	252	285	326
Coolant Temperature (°C)	60	60	60	60
Max Winding Temperature (°C)	180	180	180	180
Winding Temp at Rating (°C)	140	140	140	140
Rotor Inertia (kg-m ²)	0.05584	0.05584	0.05584	0.05584
Motor Weight (kg)	77	77	77	77
Recommended Parker Inverter	Contact Factory	Contact Factory	Contact Factory	Contact Factory

GVM210-300 Winding Performance & Selection @ 350 VDC

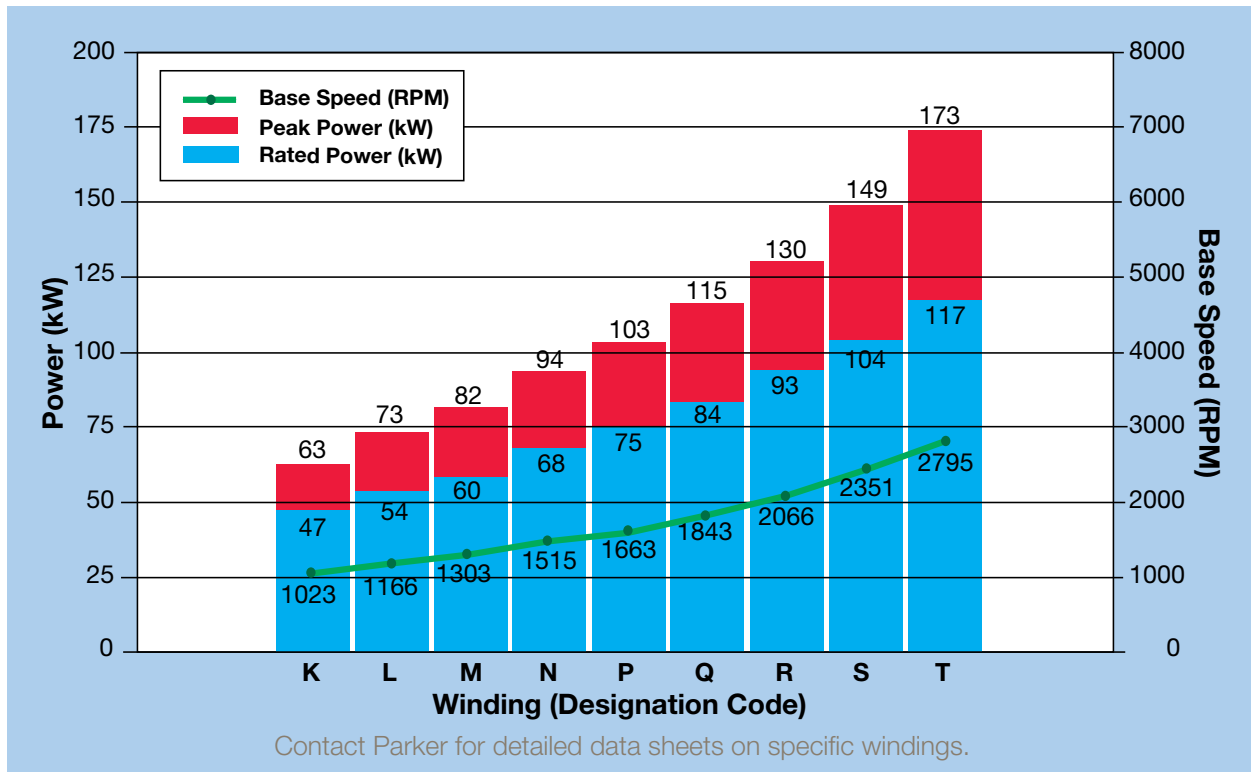

GVM210-300 Dimensions

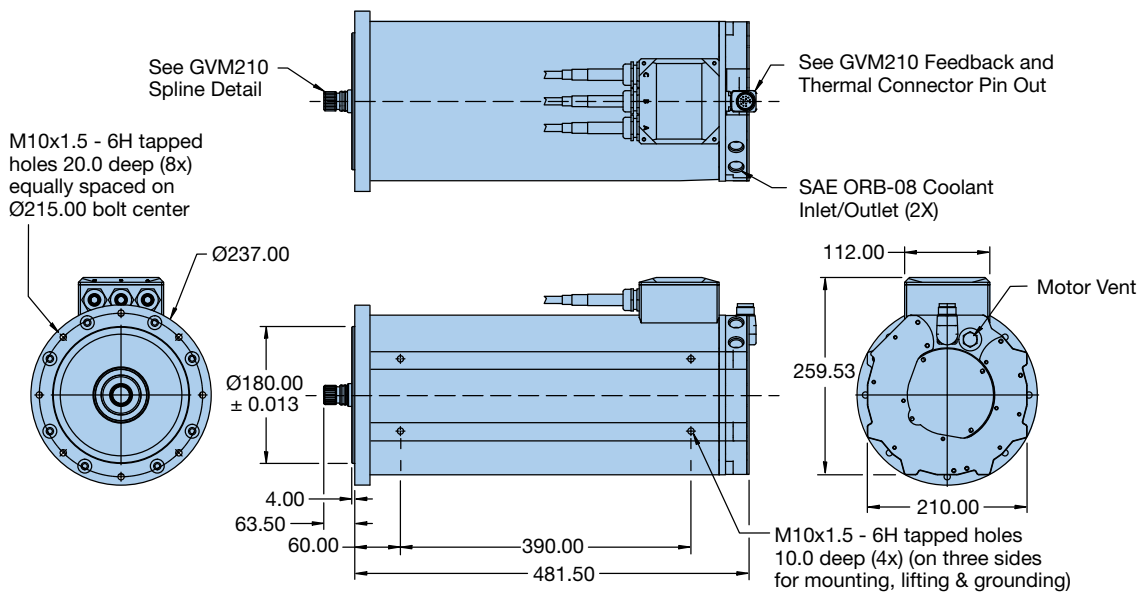

GVM210 Traction Motors & Generators

GVM210-300 Performance @ 650 VDC

Parameter	GVM210-300J	GVM210-300K	GVM210-300L	GVM210-300M	GVM210-300N
Peak Torque (Nm)	524	524	521	522	520
Base Speed (RPM)	1,735	1,948	2,221	2,545	2,884
Peak Power (kW)	108	122	140	157	179
Stall Torque Continuous (Nm)	302	301	299	300	299
Rated Torque (Nm)	239	238	248	246	245
Rated Speed (RPM)	3,122	3,506	3,776	4,221	4,713
Rated Shaft Output Power (kW)	78	88	98	109	121
Max Continuous Speed (RPM)	3,946	4,432	5,054	5,648	6,401
Stall Current Peak (Amp RMS)	226	254	287	322	363
Stall Current Continuous (Amp RMS)	113	127	144	161	182
Coolant Temperature (°C)	60	60	60	60	60
Max Winding Temperature (°C)	180	180	180	180	180
Winding Temp at Rating (°C)	140	140	140	140	140
Rotor Inertia (kg-m ²)	0.05584	0.05584	0.05584	0.05584	0.05584
Motor Weight (kg)	77	77	77	77	77
Recommended Parker Inverter	MA3	MA3	MA3	MA3	MA3

Parameter	GVM210-300P	GVM210-300Q	GVM210-300R	GVM210-300S	GVM210-300T
Peak Torque (Nm)	524	526	527	525	519
Base Speed (RPM)	3,166	3,508	3,964	4,492	5,285
Peak Power (kW)	197	218	246	280	325
Stall Torque Continuous (Nm)	302	304	304	302	298
Rated Torque (Nm)	252	248	244	243	229
Rated Speed (RPM)	5,019	5,561	6,166	6,694	7,575
Rated Shaft Output Power (kW)	132	145	157	171	182
Max Continuous Speed (RPM)	7,026	7,785	8,000	8,000	8,000
Stall Current Peak (Amp RMS)	403	450	505	571	651
Stall Current Continuous (Amp RMS)	202	225	252	285	326
Coolant Temperature (°C)	60	60	60	60	60
Max Winding Temperature (°C)	180	180	180	180	180
Winding Temp at Rating (°C)	140	140	140	140	140
Rotor Inertia (kg-m ²)	0.05584	0.05584	0.05584	0.05584	0.05584
Motor Weight (kg)	77	77	77	77	77
Recommended Parker Inverter	MA3	Contact Factory	Contact Factory	Contact Factory	Contact Factory

GVM210-300 Winding Performance & Selection @ 650 VDC

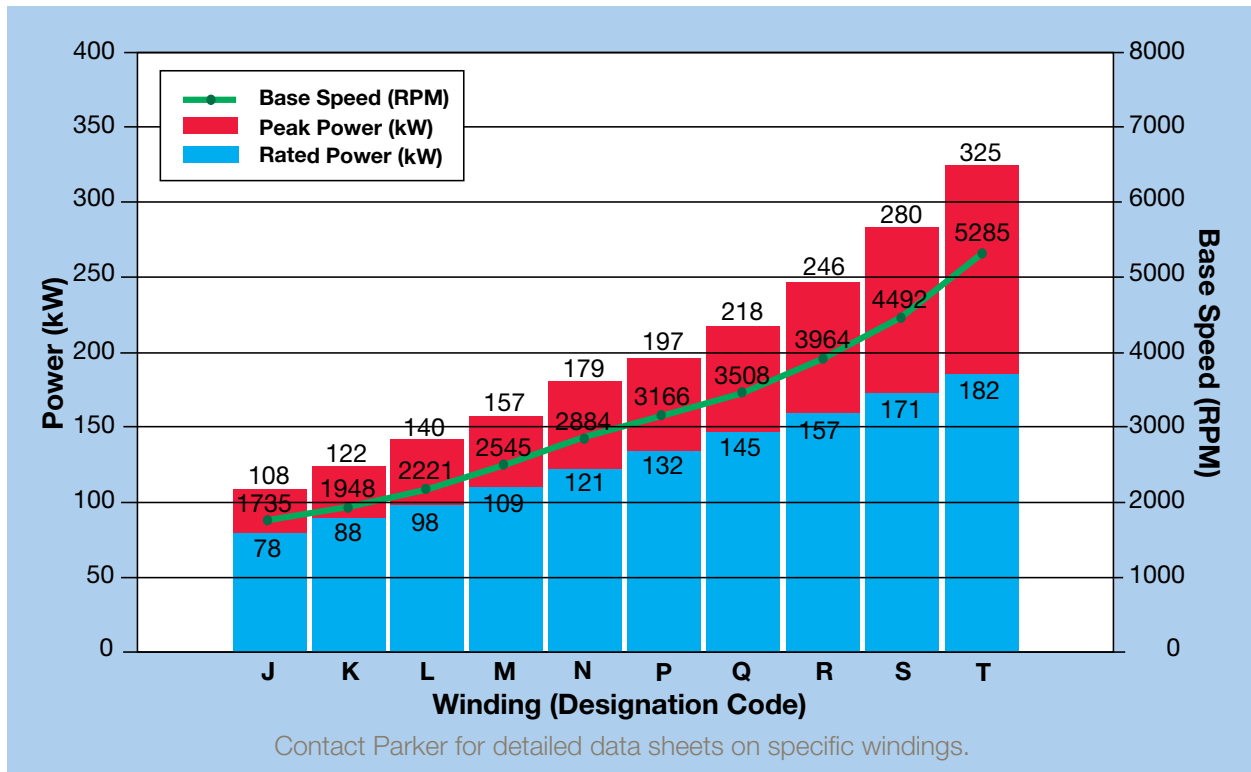

GVM210-300 Dimensions

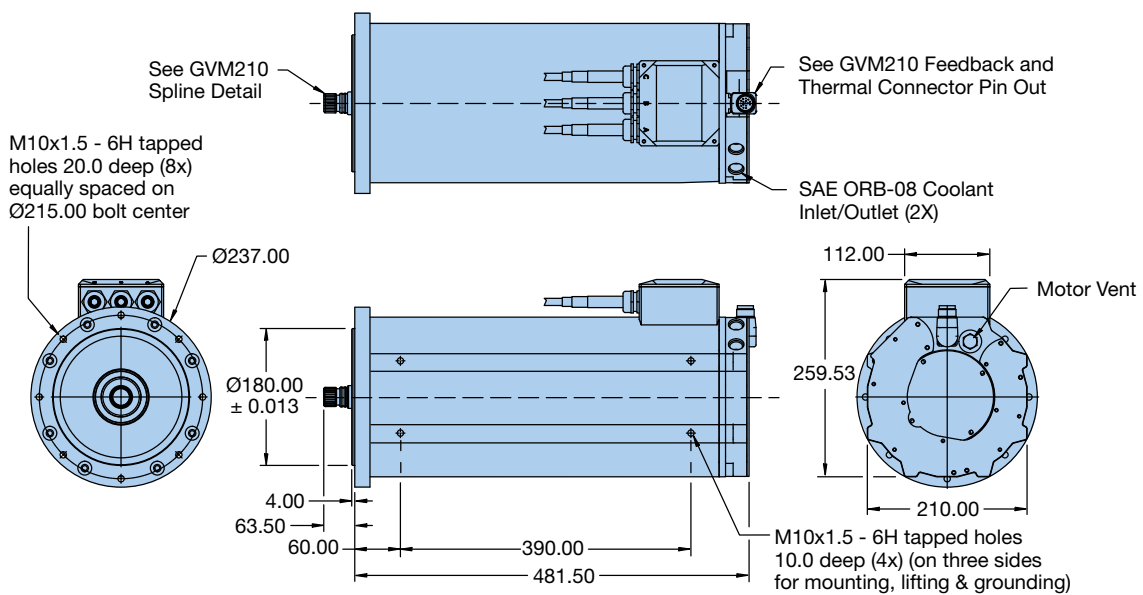

GVM210 Traction Motors & Generators

GVM210-400 Performance @ 350 VDC

Parameter	GVM210-400P	GVM210-400Q	GVM210-400R	GVM210-400S
Peak Torque (Nm)	700	703	703	700
Base Speed (RPM)	1,216	1,348	1,550	1,763
Peak Power (kW)	102	114	129	147
Stall Torque Continuous (Nm)	403	406	406	404
Rated Torque (Nm)	331	333	333	329
Rated Speed (RPM)	2,183	2,419	2,712	3,086
Rated Shaft Output Power (kW)	76	84	94	106
Max Continuous Speed (RPM)	2,837	3,144	3,525	4,012
Stall Current Peak (Amp RMS)	404	451	506	572
Stall Current Continuous (Amp RMS)	202	225	253	286
Coolant Temperature (°C)	60	60	60	60
Max Winding Temperature (°C)	180	180	180	180
Winding Temp at Rating (°C)	140	140	140	140
Rotor Inertia (kg-m ²)	0.07428	0.07428	0.07428	0.07428
Motor Weight (kg)	97	97	97	97
Recommended Parker Inverter	MA3	Contact Factory	Contact Factory	Contact Factory

GVM210-400 Winding Performance & Selection @ 350 VDC

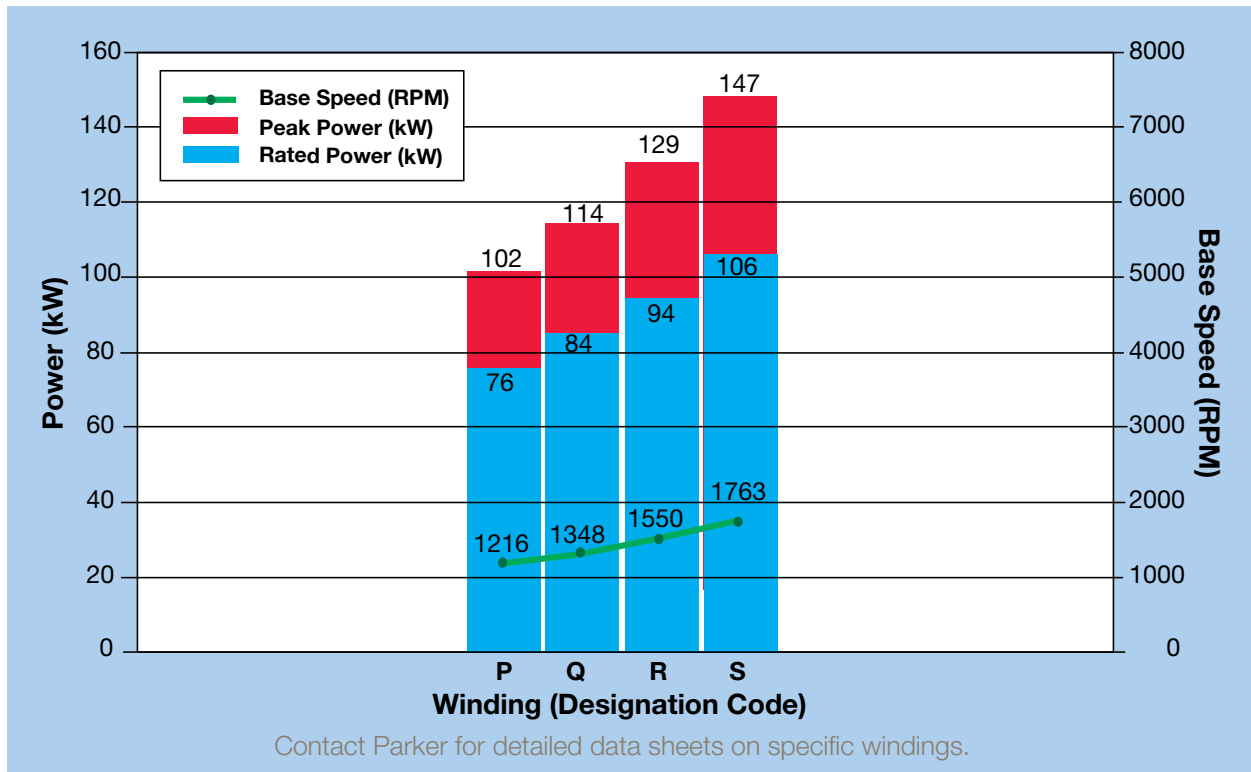

GVM210-400 Dimensions

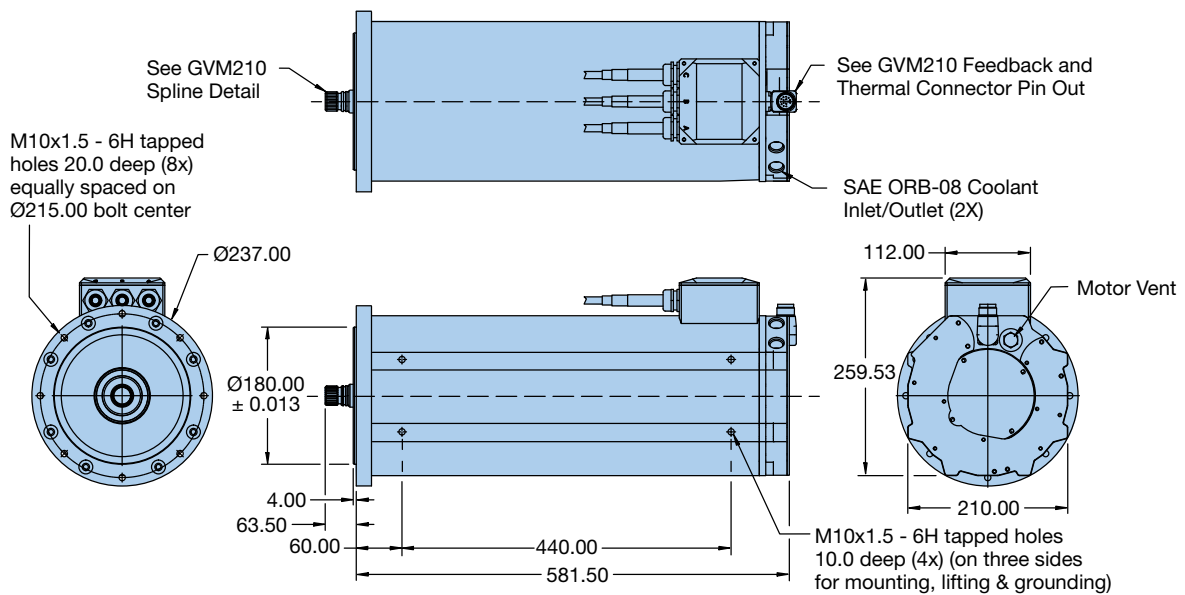

GVM210 Traction Motors & Generators

GVM210-400 Performance @ 650 VDC

Parameter	GVM210-400J	GVM210-400K	GVM210-400L	GVM210-400M	GVM210-400N
Peak Torque (Nm)	699	701	696	697	695
Base Speed (RPM)	1,268	1,425	1,666	1,862	2,110
Peak Power (kW)	107	121	138	156	177
Stall Torque Continuous (Nm)	403	404	400	401	399
Rated Torque (Nm)	326	331	318	326	322
Rated Speed (RPM)	2,309	2,557	2,999	3,259	3,693
Rated Shaft Output Power (kW)	79	89	100	111	125
Max Continuous Speed (RPM)	2,960	3,324	3,790	4,236	4,801
Stall Current Peak (Amp RMS)	227	255	288	323	364
Stall Current Continuous (Amp RMS)	113	128	144	161	182
Coolant Temperature (°C)	60	60	60	60	60
Max Winding Temperature (°C)	180	180	180	180	180
Winding Temp at Rating (°C)	140	140	140	140	140
Rotor Inertia (kg-m ²)	0.07428	0.07428	0.07428	0.07428	0.07428
Motor Weight (kg)	97	97	97	97	97
Recommended Parker Inverter	MA3	MA3	MA3	MA3	MA3

Parameter	GVM210-400P	GVM210-400Q	GVM210-400R	GVM210-400S
Peak Torque (Nm)	700	703	703	700
Base Speed (RPM)	2,316	2,567	2,950	3,357
Peak Power (kW)	196	217	245	279
Stall Torque Continuous (Nm)	403	406	406	404
Rated Torque (Nm)	333	326	331	326
Rated Speed (RPM)	3,938	4,428	4,820	5,403
Rated Shaft Output Power (kW)	137	151	167	184
Max Continuous Speed (RPM)	5,270	5,839	6,547	7,450
Stall Current Peak (Amp RMS)	404	451	506	572
Stall Current Continuous (Amp RMS)	202	225	253	286
Coolant Temperature (°C)	60	60	60	60
Max Winding Temperature (°C)	180	180	180	180
Winding Temp at Rating (°C)	140	140	140	140
Rotor Inertia (kg-m ²)	0.07428	0.07428	0.07428	0.07428
Motor Weight (kg)	97	97	97	97
Recommended Parker Inverter	MA3	Contact Factory	Contact Factory	Contact Factory

GVM210-400 Winding Performance & Selection @ 650 VDC

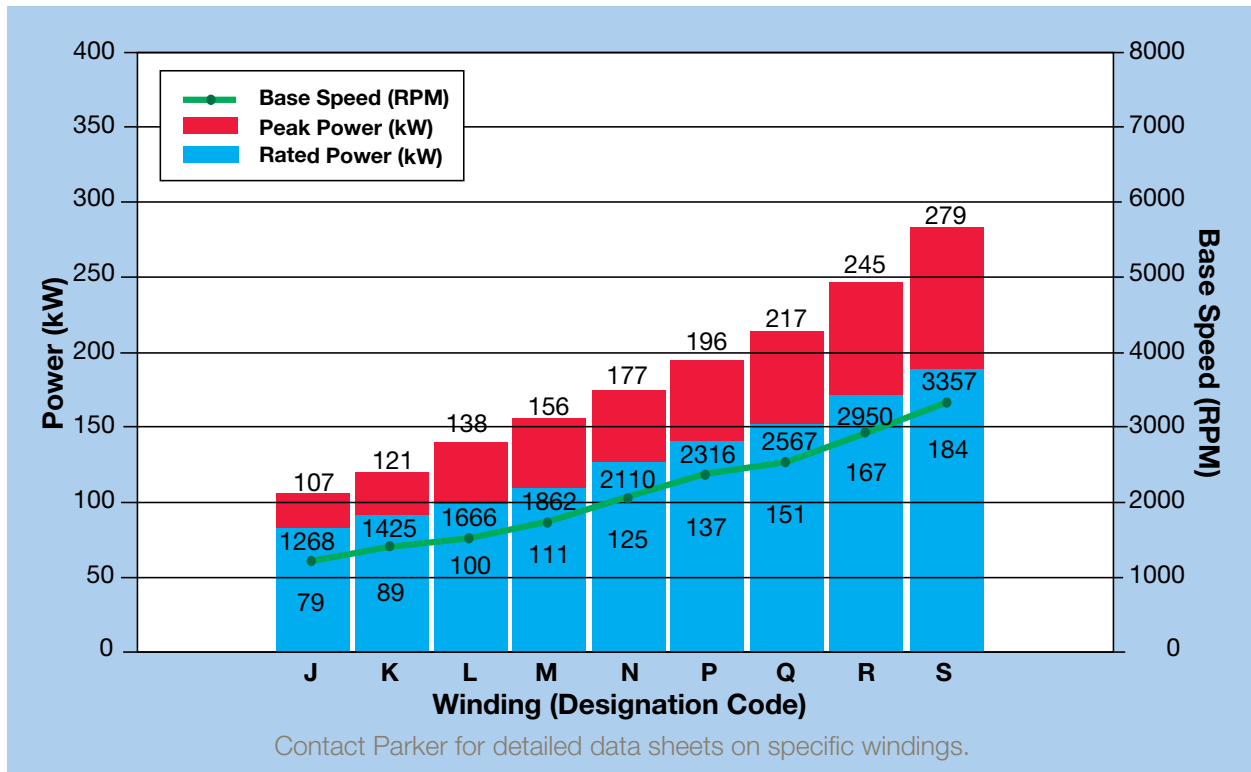

GVM210-400 Dimensions

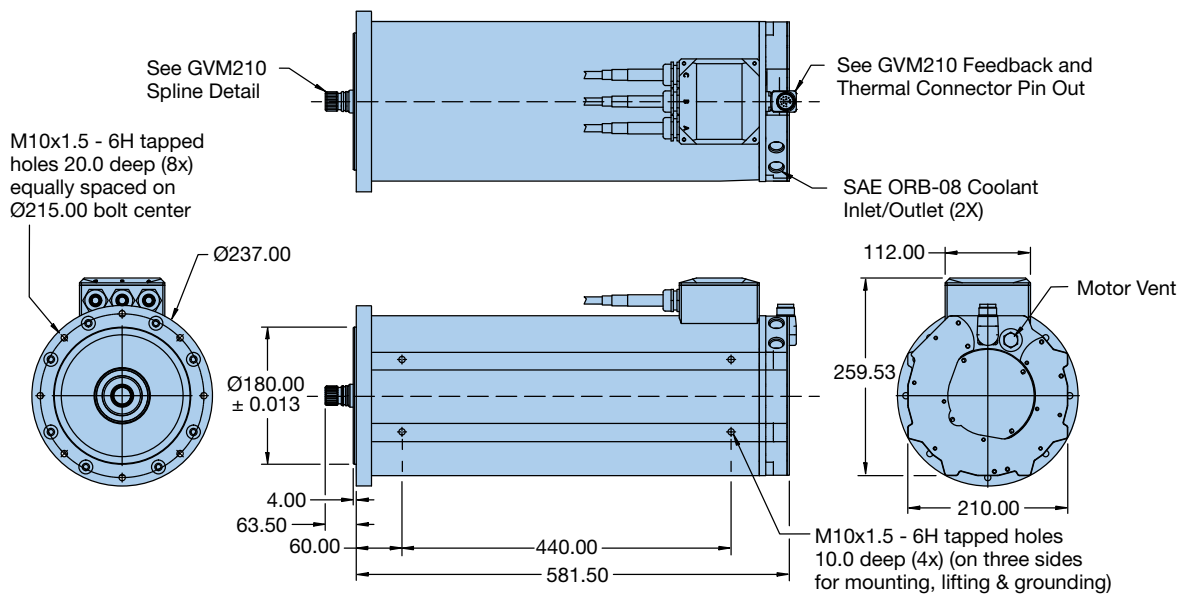

GVM210 Traction Motors & Generators

GVM210 Feedback and Thermal Connector (all motor sizes)

The Feedback and Thermal Connector option for GVM motors feature a high-quality circular, right-angle, bayonet style connector mounted to the motor body. It is made of zinc coated brass and is rated to IP68/IP69K. It also features a long internal back shell for high vibration resistance meeting SAE J1455 shock/vibe requirements.

The connector provides access to the resolver and thermal signals.

Mating cables are specified and ordered separately.

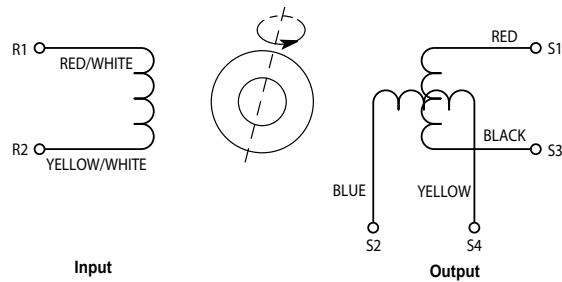
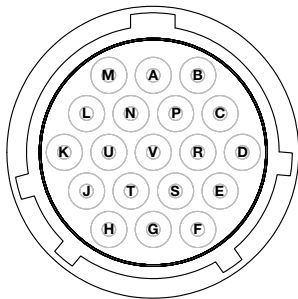

Resolver Feedback and Thermal Connector Pin Assignment

Pin Assignment	Function	Wire Color	From
A	Sin+ S2	Yellow	Resolver
B	Sin- S4	Blue	Resolver
J	Ref+ R1	White	Resolver
K	Ref- R2	Green	Resolver
E	Cos+ S1	Red	Resolver
F	Cos- S3	Black	Resolver
C	Thermistor	Pink	Thermik SNM140 PTC
D	Thermistor	Grey	Thermik SNM140 PTC
G	Thermistor	Red/White (+)	Omega 44008
H	Thermistor	Yellow/White (-)	Omega 44008

Resolver Alignment Specifications (Direction Viewed from Output Shaft)

Parameter	Value
Resolver 0° lock rotor setting	B & C+, A-
Increase feedback angle	Clockwise
Commutation direction (A-B-C)	Clockwise
Resolver poles	6 (3 pole pairs)
Input voltage	AC 7 V _{rms} 10 kHz
Primary	R1-R2
Transformation ratio	0.286 ±10%
Electrical error (mechanical angle)	± 45° maximum
Impedance Z _{ro}	120 ohms ±20%
Impedance Z _{ss} (at theta = 0°)	335 ohms nominal
Dielectric strength (60/50 Hz)	AC 500 V _{rms} 1 minute
Insulation resistance (DC 500 V)	1000 Megohms minimum

GVM210 Feedback Cable

The GVM feedback cable uses environmentally tested and validated cable jacket and connector. It contains all of the low voltage feedback signals. One required per motor.

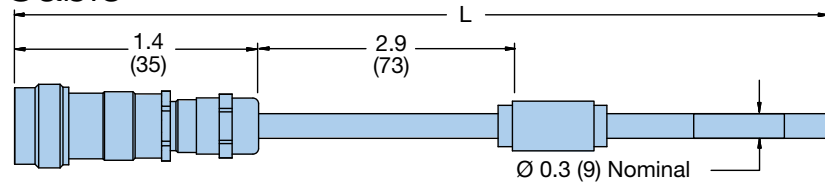

Feedback Cable

Cable Part Number	Description	Length "L" in (m)
170-00506-01	1 m Cable	39.4 (1 m)
170-00506-02	2 m Cable	78.7 (2 m)
170-00506-03	3 m Cable	118.1 (3 m)
170-00506-04	4 m Cable	157.5 (4 m)

GVM210 Phase Power Cable

The GVM power cable uses environmentally tested and validated cable jacket. One cable is required per phase, three per motor. These cables can be field installed and replaced.

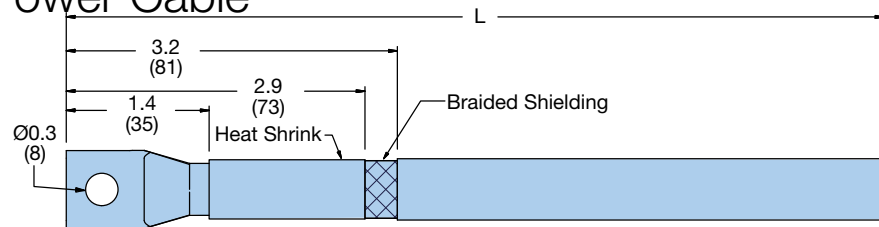

Phase Power Cable

Cable Part Number	Description	Length "L" in (m)
180-00530-01	1 m Cable	43.4 (1.1 m)
180-00530-02	2 m Cable	82.8 (2.1 m)
180-00530-03	3 m Cable	122.1 (3.1 m)
180-00530-04	4 m Cable	161.5 (4.1 m)

GVM210 Cooling

Motor Size	Voltage VDC	Min. Required Flow Rate Gal/Min (L/Min)	Expected Pressure Drop @
			Min. Flow Rate psi (bar)
GVM210-050S	350	1.1 (4.2)	0.46 (0.032)
GVM210-100J	350	1.1 (4.2)	0.56 (0.039)
GVM210-150M	350	1.1 (4.2)	0.66 (0.046)
GVM210-200P	350	1.1 (4.2)	0.82 (0.057)
GVM210-300N	650	1.2 (4.5)	0.89 (0.061)
GVM210-400R	650	1.2 (4.5)	1.30 (0.090)

Notes:

1. The maximum allowable cooling system pressure is 60 psi.
2. To achieve continuous operation outlined for listed winding, inlet temperature held to 60 °C, 50/50 mix of water/ethylene glycol.
3. Flow rate changes with operating point and winding. Pressure drop changes with flow rate and fluid type.

Contact Parker for specific flow and pressure requirements for the winding and operation point selected.

Recommended Parker Fittings

ID Hose Size in (mm)	Straight Barb Fitting	45° Barb Fitting	90° Barb Fitting
0.500 (12.70 mm)	685HB-8-8	1795HB-8-8	1695HB-8-8
0.625 (15.86 mm)	685HB-10-8	1795HB-10-8	1695HB-10-8
0.750 (19.05 mm)	685HB-12-8	1795HB-12-8	1695HB-12-8

Please visit www.parkerstore.com to order fittings.

GVM210 Traction Motors & Generators

GVM210 Spline Detail

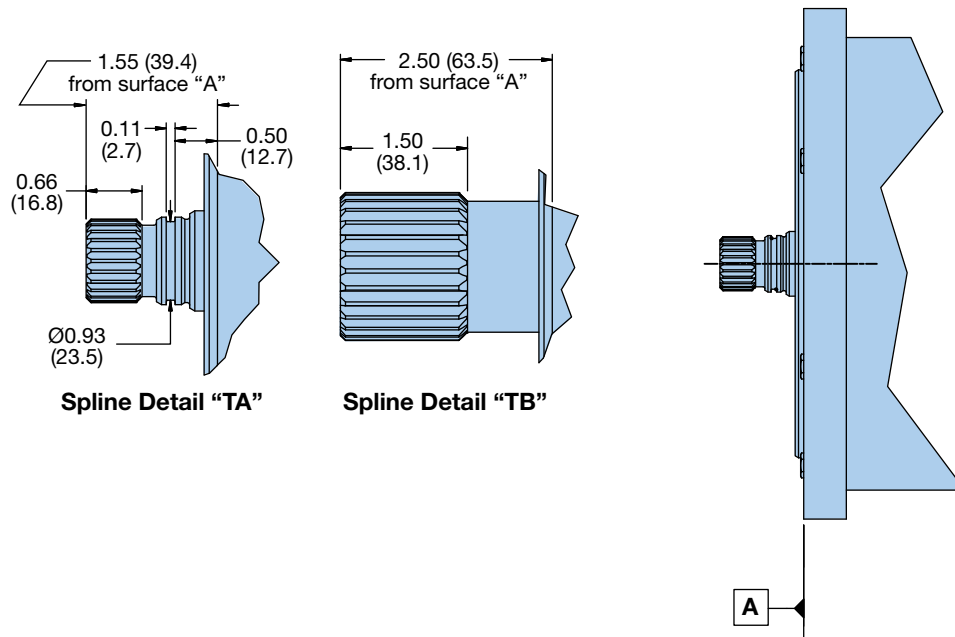

Spline Info — Dimension in Inches (mm)	TA	TB
GVM210 Motor Frame Size	050 – 200	300 – 400
Involute Spline	ANSI B92.2M	ANSI B92.1
Side Fit	Flat Root Class 6h	Fillet Root Class 5
Number of Teeth	24	27
Module	1.0000	—
Spline Pitch	—	16/32
Pressure Angle	30.0°	30.0°
Pitch Diameter (ref)	0.9449 (24.000)	1.6875 (42.863)
Base Diameter (ref)	0.8183 (20.785)	1.461418 (37.12000)
Major Diameter	0.984/0.974 (25.00/24.75)	1.750/1.745 (44.45/44.32)
Minor Diameter	0.886/0.876 (22.50/22.26)	1.546 (39.27)
Form Diameter (max)	0.901 (22.89)	1.621 (41.17)
Circular Tooth Thickness Max Effective	0.0619 (1.571)	0.0967 (2.456)
Circular Tooth Thickness Min Actual	0.585 (1.485)	0.0953 9 (2.421)
Pin Diameter (ref)	0.835 (2.120)	0.120 (3.048)
Measurement Over Pins (ref)	1.0819/1.0787 (27.479/27.399)	1.8685/1.8664 (47.460/47.407)

GVM210 Ordering Information

Fill in an order code from each of the numbered fields to create a complete model order code.

Order Example:

①	②	③	④	⑤	⑥	⑦	⑧	⑨	⑩	⑪	⑫
GVM	210	150	A	6	W	R	A	A	TA	1	G

- ① **Series**
GVM Global Vehicle Motor
- ② **Frame**
210
- ③ **Rotor Length**
050 50 mm rotor
100 100 mm rotor
150 150 mm rotor
200 200 mm rotor
300 300 mm rotor
400 400 mm rotor
- ④ **Winding Letter Code***
* Select based on appropriate performance characteristics, see specific motor size winding charts, pages 4 – 27))
- ⑤ **Winding Numeric Code**
6
- ⑥ **Cooling Configuration**
W Water cooling
- ⑦ **Feedback**
R Resolver
- ⑧ **Thermal Switch**
A PTC
- ⑨ **Thermal Sensor**
A Omega 44008 30 kOhm thermistor
- ⑩ **Output Shaft Configuration**
TA Traction spline 1 (050 – 200 rotor sizes)
TB Traction spline 2 (300 – 400 rotor sizes)
- ⑪ **Power Connection**
1 Terminal box
- ⑫ **Option**
G Global

Cables Options

Description	Phase Power Cable*	Feedback Cable
1 m Cable	180-00530-01	170-00506-01
2 m Cable	180-00530-02	170-00506-02
3 m Cable	180-00530-03	170-00506-03
4 m Cable	180-00530-04	170-00506-04

* 3 separate phase cables required per GVM Motor



Made in the USA

© 2014 Parker Hannifin Corporation
88-032356-01 Rev C

Issue Date 7.15.14

Parker战略合作伙伴



北京润诚时代科技有限公司

自动化事业部

地址：北京市朝阳区汤立路218号C座968室

邮编：100012

电话：010-84450370

传真：010-84450371

网址：www.runcheng.net