

超高真空步进电机

Ultra High Vacuum Stepper Motors

AML stepper motors are specifically designed for use in UHV environments making them ideally suited for low speed precision in-vacuum manipulation without the use of particle generating motion feed-throughs. The considerable reduction in mechanical complexity, absence of metal to metal sliding surfaces and low outgassing characteristics make these motors especially suitable for sensitive handling applications



FEATURES 1.8°, two phase hybrid stepper motors

The model D motors are two phase hybrid stepper motors, available in a range of standard sizes and torque ratings. Standard motors provide 200 full steps per revolution, are suitable for use below 1×10^{-10} mbar and temperatures between -65°C to $+175^{\circ}\text{C}$. Extended low temperature range (-196°C) versions, radiation hard versions (1×10^6 Gy), shaft modifications and hybrid bearings are all available options.

All motors are designed, cleaned, hand assembled and conditioned to UHV standards in an ISO Class 7 cleanroom.

Model	Holding Torque mNm	Detent Torque mNm	Rotor Inertia gcm ²	Max.Axial Force N	Max. Radial Force ⁽¹⁾ N	Mass g	Current Per Phase A	Phase Resistance at 20°C Ω	Phase Inductance mH
D35.1	70	8	10	9	15	190	1.0	4.7	3.8
D42.1	180	8	35	9	15	350	1.0	5.3	6.6
D42.2	360	14	68	9	15	470	1.0	6.8	10.5
D42.3	450	20	102	9	15	610	1.0	8.5	19.5
D57.1	800	30	300	13	40	700	1.0	10.5	27.0

Standard Model : D**.1-UHV-1

Vacuum environment <math> < 1 \times 10^{-10}</math> mbar
 Operating temperature -65°C to $+175^{\circ}\text{C}$
 Temperature sensor Type 'K' thermocouple standard
 Bakeout temperature 200°C
 Step angle 1.8°
 Step angle tolerance 5%
 Lead length 1.5m

标准真空步进电机满足以下指标，扩展选型请查看电机说明的最后一页。

(1) 20mm from the flange

SPEED VS TORQUE CHARACTERISTICS

The performance shown on these graphs was obtained using an SMD210 drive operating with standard settings for step division.

SMD210 is a switch-mode, bipolar, current-regulating drive with a nominal source of 67volts, optimised for use with vacuum motors. At low speed where step division is active the RSS (root sum of squares) of phase current is set to the nominal current. Over most of the speed range the drive operates in wave mode with nominal set current in only one energised phase.

Different drives will produce different speed / torque curves. Drives capable of producing a total phase current of more than 1A RSS may damage the insulation. Drives with significantly lower source voltages may result in poor high speed performance. Use of the embedded thermocouple is essential for motor protection.

-UHV-1

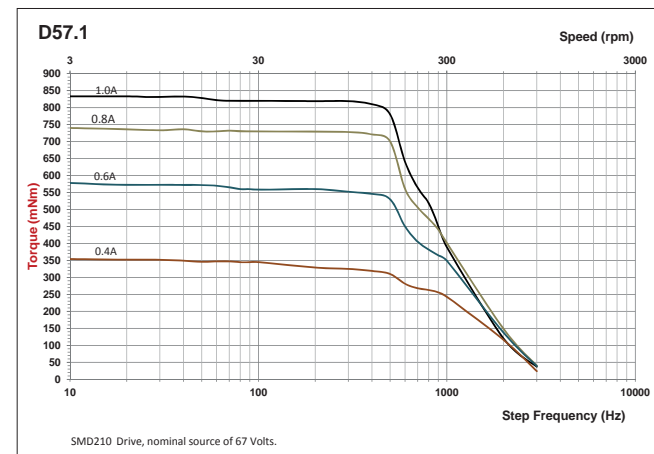
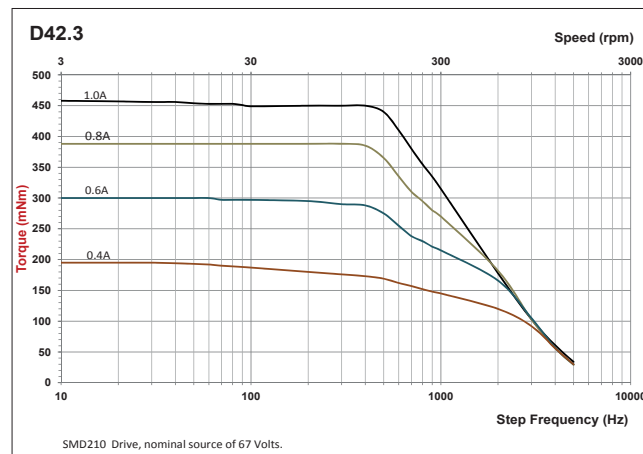
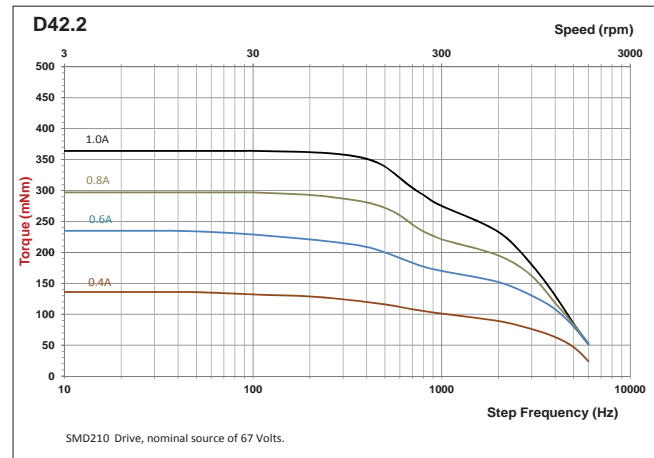
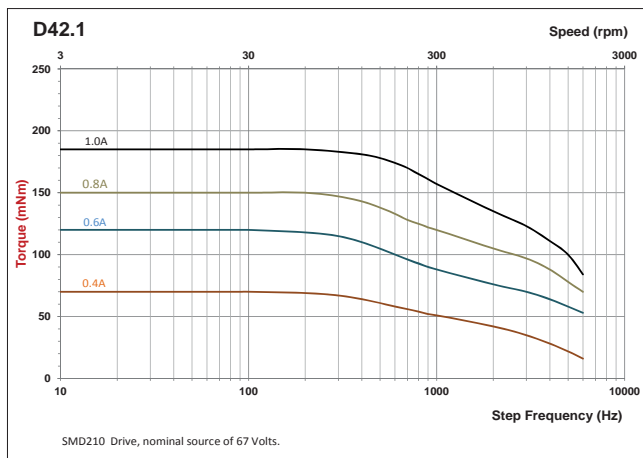
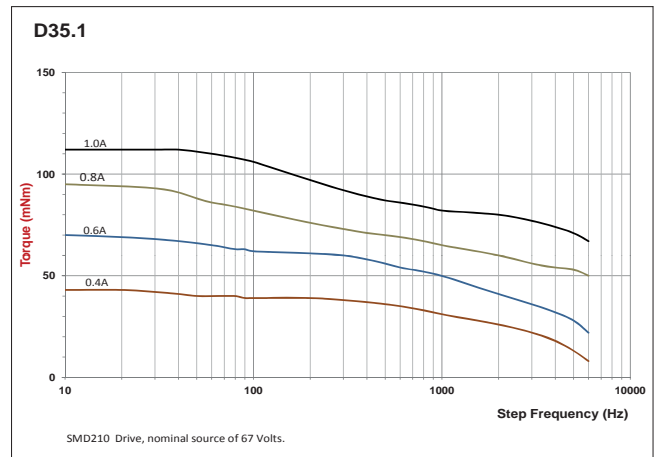

DIMENSIONS

D35.1-UHV-1

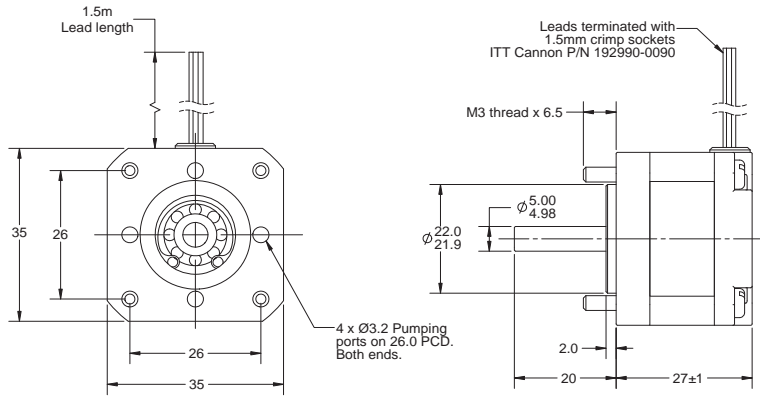

D42.X-UHV-1

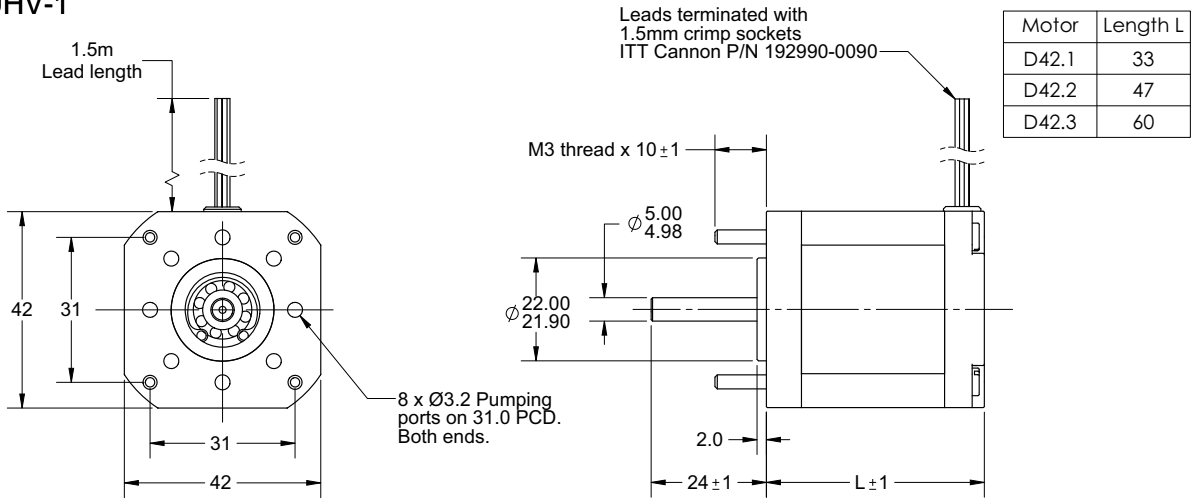

D57.1-UHV-1

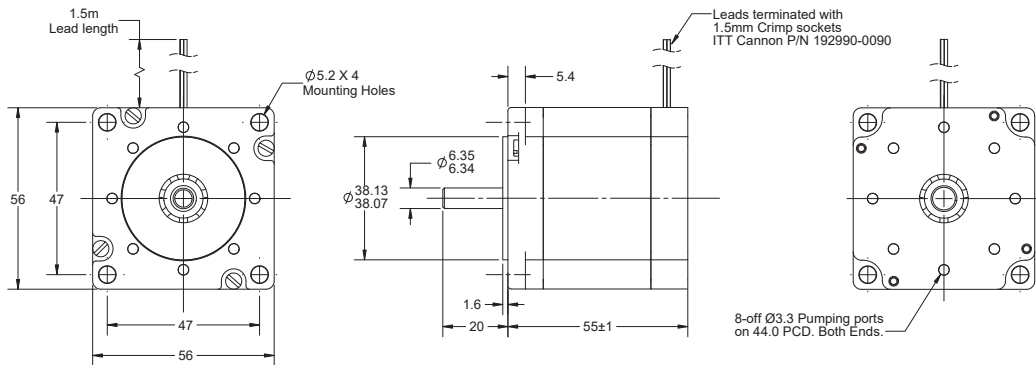

ELECTRICAL CONNECTION

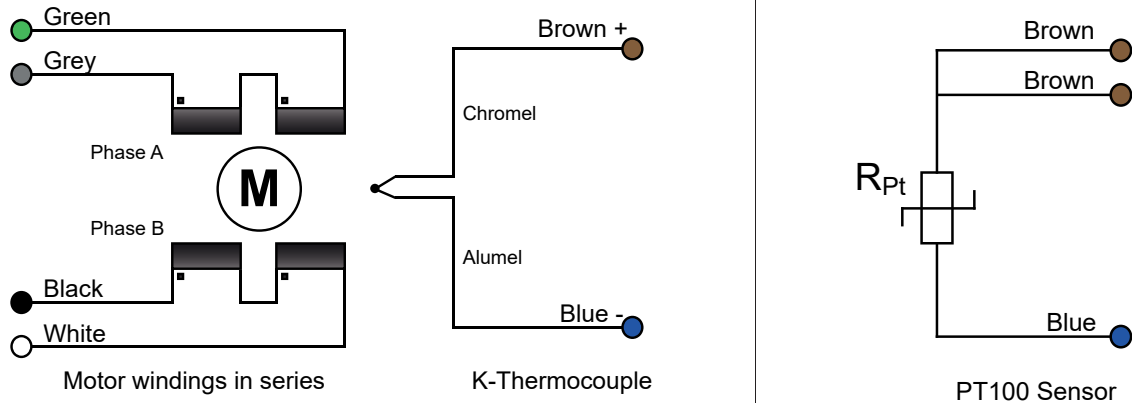

ORDERING INFORMATION

Bearings

Standard motors are fitted with open stainless steel bearings lubricated with NyeTorr® 6300 ultra low outgassing UHV grease.

For low duty applications where UHV grease is not permitted specify option 'H' hybrid bearings. These have silicon nitride ceramic balls, dry lubricated with Tungsten disulfide.

扩展选项** Options

- R-XV18**** 耐辐照总吸收剂量 - Gamma radiation hardened to 1×10^6 Gy
- C-XV18**** 超低工作环境温度 - Cryogenic. Extended operating temperature range. -196°C to $+175^\circ\text{C}$
- P-XV18**** 嵌入PT100温度传感器 - PT100 temperature sensor in lieu of thermocouple.
- X-XV18**** 定制真空步进电机输出轴 - Shaft modification. Please provide a sketch of your requirement
- H-XV18**** 特殊处理的混合陶瓷轴承 - Hybrid ceramic bearings
- PG**-**-V** 匹配真空高低温减速机 - Suitable for UHV Planetary Gearhead
- B-XV18**** 匹配真空高低温旋变 - Suitable for Vacuum Rotating Transformer

订购型号示例：D42.1-UHV-1-C-XV18-**

示例所选型号为：同时满足真空环境和超低温环境，**表示根据要求特殊定制，特殊定制编码请联系我们。

北京润诚时代科技有限公司

自动化事业部

地址：北京市朝阳区汤立路218号C座968室

邮编：100012

电话：010-84450370

传真：010-84450371

网址：www.runcheng.net