



APEX DYNAMICS, INC.

**HIGH PRECISION
PLANETARY GEARBOX**

AFX / AFXR Series



Stainless

AFX / AFXR Series

► Features:

High Torque

High Precision

Long Service Life

Low Noise

Limited Temperature Rise

More Suitable for Continuous Running



AFX



AFXR

AFX Series

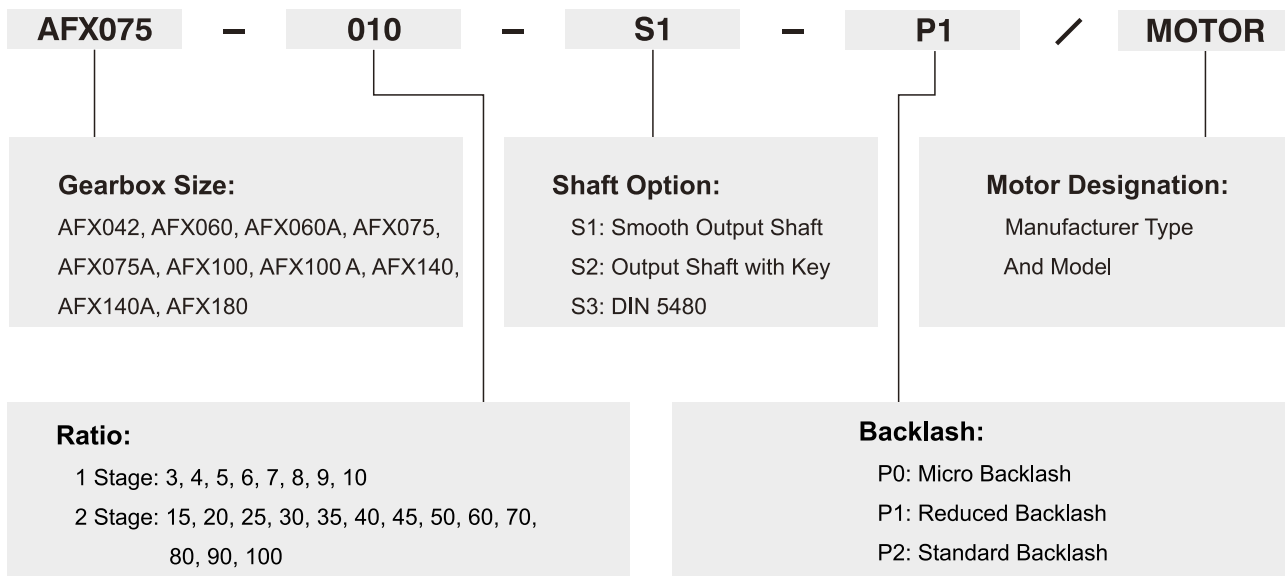

Ordering Example: AFX075-010-S1-P1 / SIEMENS 1FT6 041-4AF71

AFXR Series

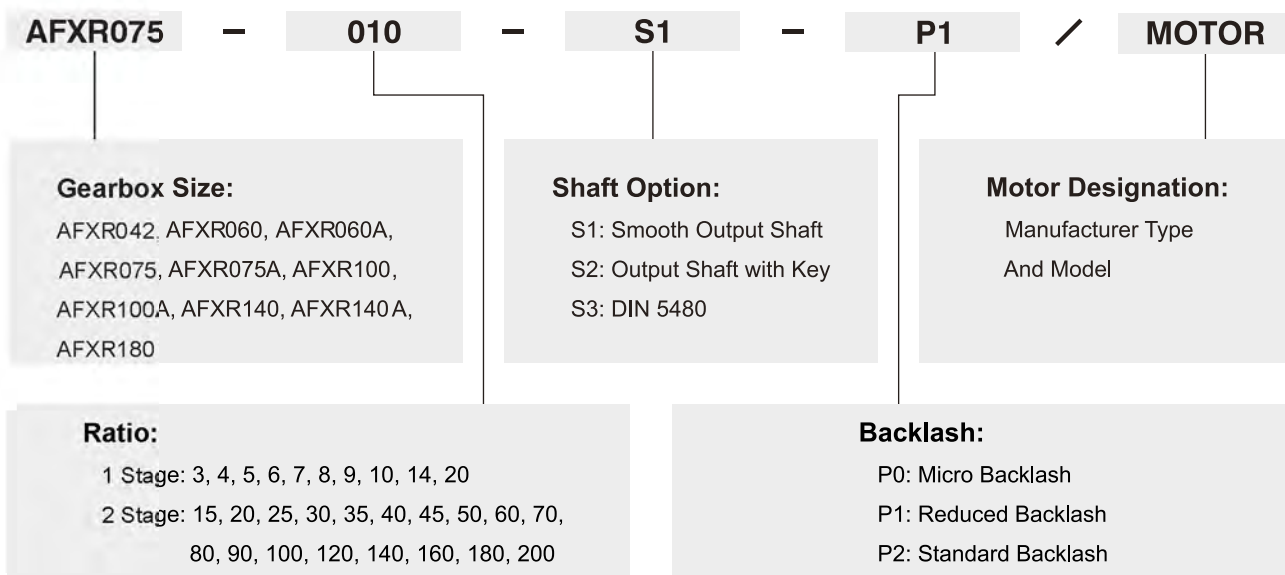

Ordering Example: AFXR075-010-S1-P1 / SIEMENS 1FT6 041-4AF71



©2019 by APEX DYNAMICS, INC.
 APEX DYNAMICS, INC. reserves modification and copyrights of all technical specifications, illustrations and drawings in this catalog in allowance for continuous products development and advancement.
 For the newest data and information, please visit <http://www.apexdyna.com/>

Specifications / AFX Series

Gearbox Performance

Model No.	Stages	Ratio ⁽¹⁾	AFX042 ^F	AFX060	AFX060A	AFX075	AFX075A	AFX100	AFX100A	AFX140	AFX140A	AFX180	
Nominal Output Torque T_{2N}	1	3	20	55	-	130	-	208	-	342	-	588	
		4	19	50	-	140	-	290	-	542	-	1,050	
		5	22	60	-	160	-	330	-	650	-	1,200	
		6	20	55	-	150	-	310	-	600	-	1,100	
		7	19	50	-	140	-	300	-	550	-	1,100	
		8	17	45	-	120	-	260	-	500	-	1,000	
		9	14	40	-	100	-	230	-	450	-	900	
		10	14	40	-	100	-	230	-	450	-	900	
		2	12	19	50	50	140	140	290	290	542	542	1,050
			15	20	55	55	130	130	208	208	342	342	588
	16		19	50	50	140	140	290	290	542	542	1,050	
	20		19	50	50	140	140	290	290	542	542	1,050	
	25		22	60	60	160	160	330	330	650	650	1,200	
	28		19	50	50	140	140	300	300	550	550	1,100	
	30		20	55	55	150	150	310	310	600	600	1,100	
	32		17	45	45	120	120	260	260	500	500	1,000	
	35		19	50	50	140	140	300	300	550	550	1,100	
	40		17	45	45	120	120	260	260	500	500	1,000	
	45	14	40	40	100	100	230	230	450	450	900		
	50	22	60	60	160	160	330	330	650	650	1,200		
60	20	55	55	150	150	310	310	600	600	1,100			
70	19	50	50	140	140	300	300	550	550	1,100			
80	17	45	45	120	120	260	260	500	500	1,000			
90	14	40	40	100	100	230	230	450	450	900			
100	14	40	40	100	100	230	230	450	450	900			
Emergency Stop Torque $T_{2NOT}^{(2)}$	Nm	1,2	3~100	3 times of Nominal Output Torque									
Nominal Input Speed n_{1N}	rpm	1,2	3~100	5,000	5,000	5,000	4,000	4,000	4,000	4,000	3,000	3,000	3,000
Max. Input Speed n_{1B}	rpm	1,2	3~100	10,000	10,000	10,000	8,000	8,000	8,000	8,000	6,000	6,000	6,000
Micro Backlash P0	arcmin	1	3~10	-	-	-	≤1	-	≤1	-	≤1	-	≤1
		2	15~100	-	-	-	-	-	≤3	≤3	≤3	≤3	≤3
Reduced Backlash P1	arcmin	1	3~10	≤3	≤3	-	≤3	-	≤3	-	≤3	-	≤3
		2	15~100	≤5	≤5	≤5	≤5	≤5	≤5	≤5	≤5	≤5	≤5
Standard Backlash P2	arcmin	1	3~10	≤5	≤5	-	≤5	-	≤5	-	≤5	-	≤5
		2	15~100	≤7	≤7	≤7	≤7	≤7	≤7	≤7	≤7	≤7	≤7
Torsional Rigidity	Nm/arcmin	1,2	3~100	3	7	7	14	14	25	25	50	50	145
Max. Radial Load $F_{2B}^{(3)}$	N	1,2	3~100	610	2,900	2,900	4,500	4,500	7,800	7,800	9,450	9,450	15,600
Max. Axial Load $F_{2aB}^{(3)}$	N	1,2	3~100	320	1,450	1,450	2,250	2,250	3,900	3,900	4,725	4,725	7,800
Efficiency η	%	1	3~10	≥97%									
		2	15~100	≥94%									
Weight	kg	1	3~10	0.6	1.7	1.5	3.5	4.1	7.4	11.3	15.8	22.5	32.7
		2	15~100	0.8	2	2	4	5.5	9	10.6	19.1	20.2	37.6
Operating Temperature	°C	1,2	3~100	-10°C~+90°C									
Lubrication		1,2	3~100	Synthetic lubrication oils									
Degree of Gearbox Protection		1,2	3~100	IP65									
Mounting Position		1,2	3~100	all directions									
Noise ⁽⁴⁾	dB	1,2	3~100	≤56	≤58	≤60	≤60	≤63	≤63	≤65	≤65	≤67	≤67

(1) Ratio ($i=N_{in}/N_{out}$)

(2) Max. acceleration torque $T_{2B} = 60\%$ of T_{2NOT}

(3) Applied to the output shaft center at 100 rpm

(4) The dB values are measured by gearbox with ratio 10 (1-stage) or ratio 100 (2-stage), no loading at 3,000 RPM or at the respective Nominal Input Speed by bigger model size.

By lower ratio and/or higher RPM, the noise level could be 3 to 5 dB higher.

Gearbox Inertia

Model No.		Stages	Ratio ⁽¹⁾	AFX042	AFX060	AFX060A	AFX075	AFX075A	AFX100	AFX100A	AFX140	AFX140A	AFX180
Mass Moments of Inertia J _i	kg · cm ²	1	3	0.03	0.16	–	0.61	–	3.25	–	9.21	–	28.98
			4	0.03	0.14	–	0.48	–	2.74	–	7.54	–	23.67
			5	0.03	0.13	–	0.47	–	2.71	–	7.42	–	23.29
			6	0.03	0.13	–	0.45	–	2.65	–	7.25	–	22.75
			7	0.03	0.13	–	0.45	–	2.62	–	7.14	–	22.48
			8	0.03	0.13	–	0.44	–	2.58	–	7.07	–	22.59
			9	0.03	0.13	–	0.44	–	2.57	–	7.04	–	22.53
			10	0.03	0.13	–	0.44	–	2.57	–	7.03	–	22.51
			12	0.03	0.03	0.16	0.16	0.61	0.61	3.25	3.25	9.21	9.21
			15	0.03	0.03	0.13	0.13	0.47	0.47	3.25	2.71	9.21	7.42
		16	0.03	0.03	0.14	0.14	0.48	0.48	2.74	2.74	7.54	7.54	
		20	0.03	0.03	0.13	0.13	0.47	0.47	2.74	2.71	7.54	7.42	
		25	0.03	0.03	0.13	0.13	0.47	0.47	2.71	2.71	7.42	7.42	
		28	0.03	0.03	0.14	0.14	0.48	0.48	2.74	2.74	7.54	7.54	
		30	0.03	0.03	0.13	0.13	0.47	0.47	2.71	2.71	7.42	7.42	
		32	0.03	0.03	0.14	0.14	0.48	0.48	2.74	2.74	7.54	7.54	
		35	0.03	0.03	0.13	0.13	0.47	0.47	2.71	2.71	7.42	7.42	
		40	0.03	0.03	0.13	0.13	0.47	0.47	2.71	2.71	7.42	7.42	
		45	0.03	0.03	0.13	0.13	0.47	0.47	2.71	2.71	7.42	7.42	
		50	0.03	0.03	0.13	0.13	0.44	0.44	2.57	2.57	7.03	7.03	
60	0.03	0.03	0.13	0.13	0.44	0.44	2.57	2.57	7.03	7.03			
70	0.03	0.03	0.13	0.13	0.44	0.44	2.57	2.57	7.03	7.03			
80	0.03	0.03	0.13	0.13	0.44	0.44	2.57	2.57	7.03	7.03			
90	0.03	0.03	0.13	0.13	0.44	0.44	2.57	2.57	7.03	7.03			
100	0.03	0.03	0.13	0.13	0.44	0.44	2.57	2.57	7.03	7.03			

Dimensions (1-stage, Ratio $i=3\sim 10$) / AFX Series

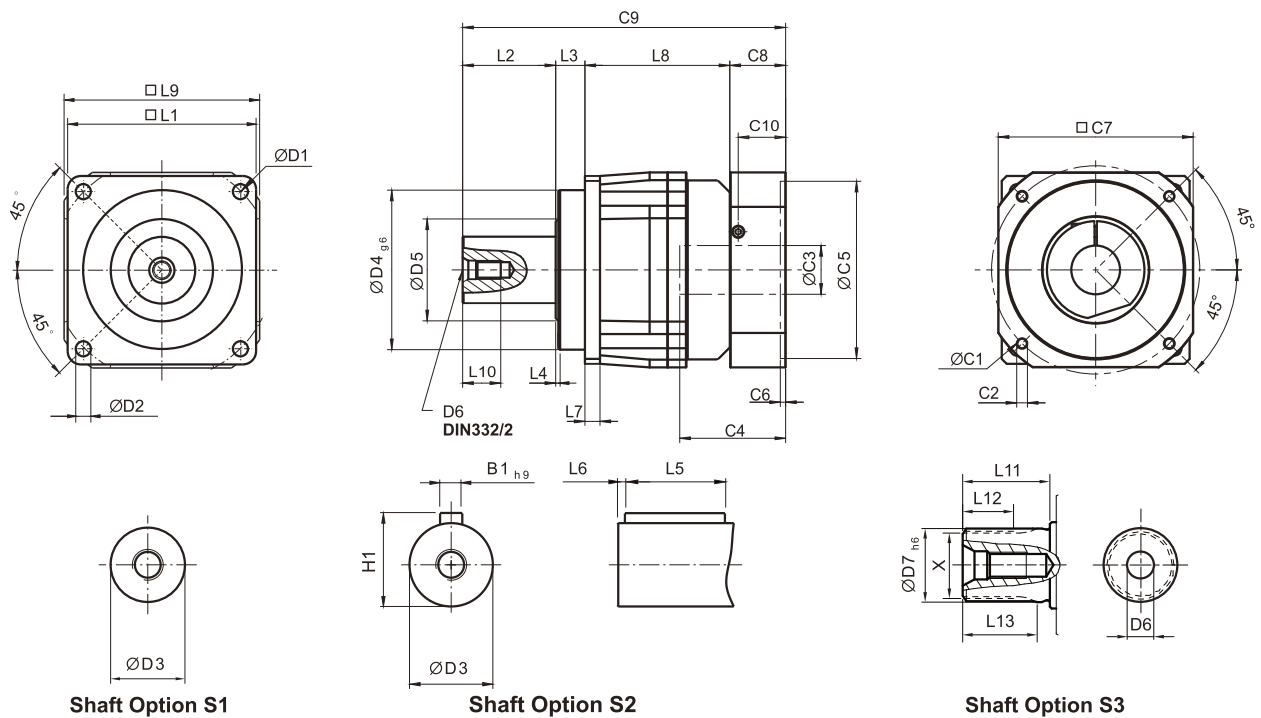

[unit: mm]

Dimension	AFX042	AFX060	AFX075	AFX100	AFX140	AFX180
D1	50	68	85	120	165	215
D2	3.4	5.5	6.8	9	11	13
D3	12 _{j6}	16 _{h6}	22 _{h6}	32 _{h6}	40 _{h6}	55 _{h6}
D4 g6	35	60	70	90	130	160
D5	22	21	30	40	75	95
D6	M4 x 0.7P	M5 x 0.8P	M8 x 1.25P	M12 x 1.75P	M16 x 2P	M20 x 2.5P
D7 h6	-	16	22	32	40	55
L1	42	62	76	105	142	180
L2	19.5	28.5	36.5	58	82	82
L3	6.5	20	19.5	30	30	30
L4	1	1.5	1.5	2	3	3
L5	14	25	32	40	63	70
L6	2	2	3	5	5	6
L7	4	6	7	10	12	15
L8	31	62	84	103.5	132	180.5
L9	42	70	90	115	142	180
L10	10	12.5	19	28	36	42
L11	-	26	26	26	40	41.5
L12	-	15	15	15	20	21.5
L13	-	21	22.5	23	33.5	33.5
C1 ¹	46	70	100	130	165	215
C2 ¹	M4 x 0.7P	M5 x 0.8P	M6 x 1P	M8 x 1.25P	M10 x 1.5P	M12 x 1.75P
C3 ¹	≤11 / ≤12 ²	≤14 / ≤16 ²	≤19 / ≤24	≤32	≤38	≤48
C4 ¹	25	34	40	50	60	85
C5 ¹	30	50	80	110	130	180
C6 ¹	3.5	8	4	5	6	6
C7 ¹	42	60	90	115	142	190
C8 ¹	29.5	19	17	19.5	22.5	29
C9 ¹	86.5	129.5	157	211	266.5	321.5
C10 ¹	8.75	13.5	10.75	13	15	20.75
B1 h9	4	5	6	10	12	16
H1	13.5	18	24.5	35	43	59
X DIN5480	-	W16x0.8x 30x18x6m	W22x1.25x 30x16x6m	W32x1.25x 30x24x6m	W40x2x 30x18x6m	W55x2x 30x26x6m

1. C1-C10 are motor specific dimensions (metric std shown). Refer to www.apexdyna.com and Design Tool to view your specific motor mounting system.

2. AFX042 ratio 5, 10 offers C3 ≤ 12 option. AFX060 ratio 5, 10 offers C3 ≤ 16 option

Dimensions (2-stage, Ratio $i=15\sim 100$) / AFX Series

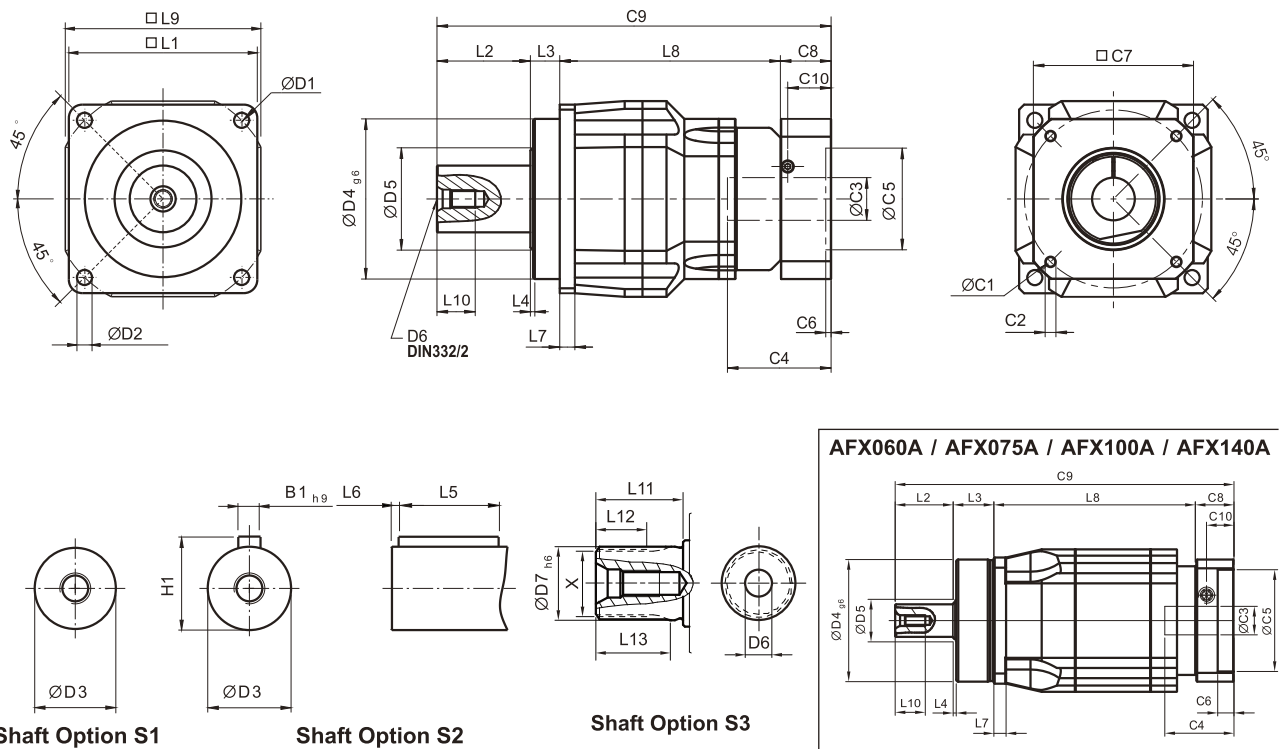

[unit: mm]

Dimension	AFX042	AFX060	AFX060A	AFX075	AFX075A	AFX100	AFX100A	AFX140	AFX140A	AFX180
D1	50	68		85		120		165		215
D2	3.4	5.5		6.8		9		11		13
D3	12 _{js}	16 _{h6}		22 _{h6}		32 _{h6}		40 _{h6}		55 _{h6}
D4 g6	35	60		70		90		130		160
D5	22	21		30		40		75		95
D6	M4x0.7P	M5x0.8P		M8x1.25P		M12x1.75P		M16x2P		M20x2.5P
D7 h6	-	16		22		32		40		55
L1	42	62		76		105		142		180
L2	19.5	28.5		36.5		58		82		82
L3	6.5	20		19.5		30		30		30
L4	1	1.5		1.5		2		3		3
L5	14	25		32		40		63		70
L6	2	2		3		5		5		6
L7	4	6		7		10		12		15
L8	58.5	73	99	117	132	145	164.5	188.5	203.5	236
L9	42	70		90		115		142		180
L10	10	12.5		19		28		36		42
L11	-	26		26		26		40		41.5
L12	-	15		15		15		20		21.5
L13	-	21		22.5		23		33.5		33.5
C1 ³	46	46	70	70	100	100	130	130	165	165
C2 ³	M4x0.7P	M4x0.7P	M5x0.8P	M5x0.8P	M6x1P	M6x1P	M8x1.25P	M8x1.25P	M10x1.5P	M10x1.5P
C3 ³	≤11/≤12	≤11/≤12	≤14/≤16	≤14/≤15.875/≤16	≤19/≤24	≤19/≤24	≤32	≤32	≤38	≤38
C4 ³	25	25	34	34	40	40	50	50	60	60
C5 ³	30	30	50	50	80	80	110	110	130	130
C6 ³	3.5	3.5	8	8	4	4	5	5	6	6
C7 ³	42	42	60	60	90	90	115	115	142	142
C8 ³	29.5	29.5	19	19	17	17	19.5	19.5	22.5	22.5
C9 ³	114	151	166.5	192	205	250	272	320	338	370.5
C10 ³	8.75	8.75	13.5	13.5	10.75	10.75	13	13	15	15
B1 h9	4	5		6		10		12		16
H1	13.5	18		24.5		35		43		59
X DIN5480	-	W16x0.8x 30x18x6m		W22x1.25x 30x16x6m		W32x1.25x 30x24x6m		W40x2x 30x18x6m		W55x2x 30x26x6m

3. C1-C10 are motor specific dimensions (metric std shown). Refer to www.apexdyna.com and Design Tool to view your specific motor mounting system.

Specifications / AFXR Series

Gearbox Performance

Model No.	Stages	Ratio ⁽¹⁾	AFXR042 ^f	AFXR060	AFXR060A	AFXR075	AFXR075A	AFXR100	AFXR100A	AFXR140	AFXR140A	AFXR180	
Nominal Output Torque T_{2N}	1	3	9	36	-	90	-	195	-	342	-	588	
		4	12	48	-	120	-	260	-	520	-	1,040	
		5	15	60	-	150	-	325	-	650	-	1,200	
		6	18	55	-	150	-	310	-	600	-	1,100	
		7	19	50	-	140	-	300	-	550	-	1,100	
		8	17	45	-	120	-	260	-	500	-	1,000	
		9	14	40	-	100	-	230	-	450	-	900	
		10	14	60	-	150	-	325	-	450	-	1,200	
		12	-	55	-	150	-	310	-	600	-	1,100	
		14	-	42	-	140	-	300	-	550	-	1,100	
		16	-	45	-	120	-	260	-	500	-	1,000	
	20	-	40	-	100	-	230	-	450	-	900		
	Nm	2	12	12	-	-	-	-	-	-	-	-	-
			15	14	-	-	-	-	-	-	-	-	-
			16	15	-	-	-	-	-	-	-	-	-
			20	14	-	-	-	-	-	-	-	-	-
			25	15	60	60	150	150	325	325	650	650	1,200
			28	19	50	50	140	140	300	300	550	550	1,100
			30	20	55	55	150	150	310	310	600	600	1,100
		32	17	45	45	120	120	260	260	500	500	1,000	
		35	19	50	50	140	140	300	300	550	550	1,100	
		40	17	45	45	120	120	260	260	500	500	1,100	
		45	14	40	40	100	100	230	230	450	450	900	
		50	14	60	60	150	150	325	325	650	650	1,200	
		60	20	55	55	150	150	310	310	600	600	1,100	
		70	19	50	50	140	140	300	300	550	550	1,100	
		80	17	45	45	120	120	260	260	500	500	1,000	
		90	14	40	40	100	100	230	230	450	450	900	
		100	14	40	60	100	150	230	325	450	650	900	
		120	-	-	55	150	150	310	310	600	600	1,100	
		140	-	-	50	140	140	300	300	550	550	1,100	
	160	-	-	45	120	120	260	260	550	550	1,000		
	180	-	-	40	100	100	230	230	450	450	900		
200	-	-	40	100	100	230	230	450	450	900			
Emergency Stop Torque $T_{2NOT}^{(2)}$	Nm	1,2	3~200	3 times of Nominal Output Torque									
Nominal Input Speed n_{1N}	rpm	1,2	3~200	5,000	5,000	5,000	4,000	4,000	4,000	4,000	3,000	3,000	3,000
Max. Input Speed n_{1B}	rpm	1,2	3~200	10,000	10,000	10,000	8,000	8,000	8,000	8,000	6,000	6,000	6,000
Micro Backlash P0	arcmin	1	3~20	-	-	-	≤2	-	≤2	-	≤2	-	≤2
		2	25~200	-	-	-	≤4	≤4	≤4	≤4	≤4	≤4	≤4
Reduced Backlash P1	arcmin	1	3~20	≤4	≤4	-	≤4	-	≤4	-	≤4	-	≤4
		2	25~200	≤7	≤7	≤7	≤7	≤7	≤7	≤7	≤7	≤7	≤7
Standard Backlash P2	arcmin	1	3~20	≤6	≤6	-	≤6	-	≤6	-	≤6	-	≤6
		2	25~200	≤9	≤9	≤9	≤9	≤9	≤9	≤9	≤9	≤9	≤9
Torsional Rigidity	Nm/arcmin	1,2	3~200	3	7	7	14	14	25	25	50	50	145
Max. Radial Load $F_{2RB}^{(3)}$	N	1,2	3~200	610	2,900	2,900	4,500	4,500	7,800	7,800	9,450	9,450	15,600
Max. Axial Load $F_{2aB}^{(3)}$	N	1,2	3~200	320	1,450	1,450	2,250	2,250	3,900	3,900	4,725	4,725	7,800
Efficiency η	%	1	3~20	≥95%									
		2	25~200	≥92%									
Weight	kg	1	3~20	0.9	2.7	3.7	6.1	7.9	12.2	16	25.3	32	50.2
		2	25~200	1.2	2.4	2.8	4.8	8	11.6	15.1	24	29.2	47.4
Operating Temperature	°C	1,2	3~200	-10°C~+90°C									
Lubrication		1,2	3~200	Synthetic lubrication oils									
Degree of Gearbox Protection		1,2	3~200	IP65									
Mounting Position		1,2	3~200	all directions									
Noise ⁽⁴⁾	dB	1,2	3~200	≤61	≤63	≤65	≤65	≤68	≤68	≤70	≤70	≤72	≤72

(1) Ratio ($i=N_{in}/N_{out}$)(2) Max. acceleration torque $T_{2B} = 60\%$ of T_{2NOT}

(3) Applied to the output shaft center at 100 rpm

(4) The dB values are measured by gearbox with ratio 10 (1-stage) or ratio 100 (2-stage), no loading at 3,000 RPM or at the respective Nominal Input Speed by bigger model size.

By lower ratio and/or higher RPM, the noise level could be 3 to 5 dB higher.

Gearbox Inertia

Model No.	Stages	Ratio ⁽¹⁾	AFXR042	AFXR060	AFXR060A	AFXR075	AFXR075A	AFXR100	AFXR100A	AFXR140	AFXR140A	AFXR180	
Mass Moments of Inertia J,	1	3~10	0.09	0.35	–	2.25	–	6.84	–	23.4	–	68.9	
		12~20	–	0.31	–	1.87	–	6.25	–	21.8	–	65.6	
	2	12~20											
		15	0.09	–	–	–	–	–	–	–	–	–	–
		20	0.09	–	–	–	–	–	–	–	–	–	–
		25~100	0.09	0.09	0.35	0.35	2.25	2.25	6.84	6.84	23.4	23.4	
		120~200	–	–	0.31	0.31	1.87	1.87	6.25	6.25	21.8	21.8	

Dimensions (1-stage, Ratio $i=3\sim 20$) / AFXR Series

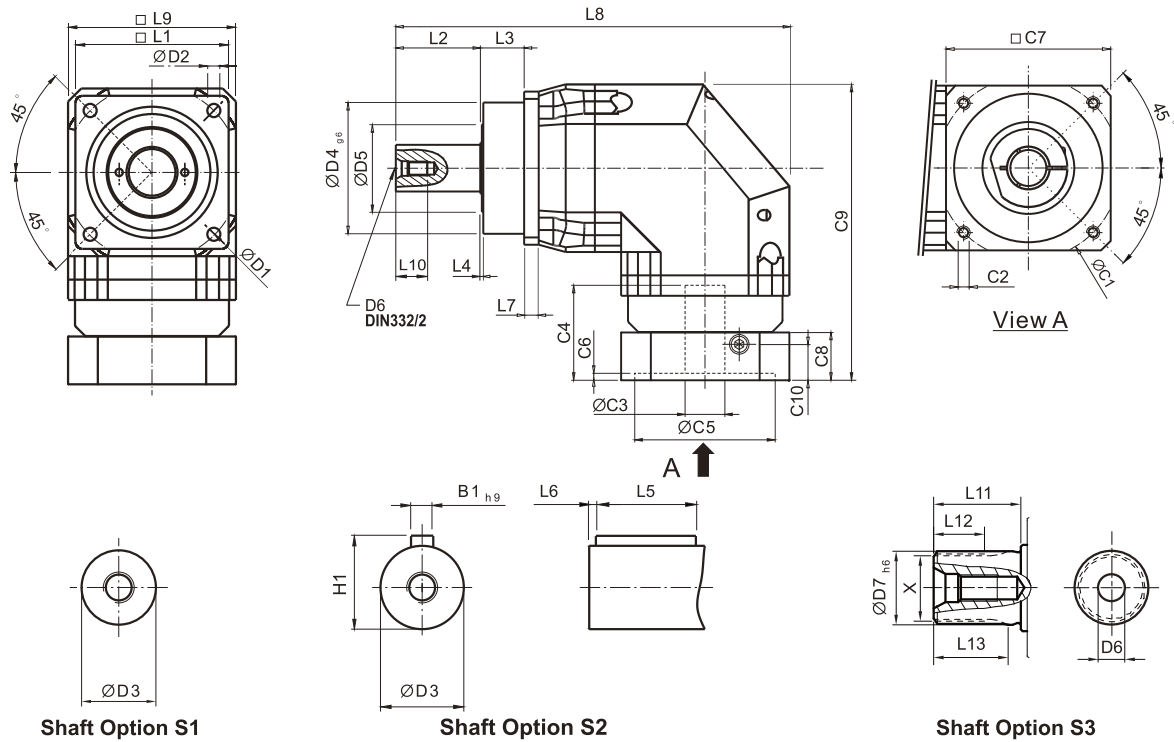

[unit: mm]

Dimension	AFXR042	AFXR060	AFXR075	AFXR100	AFXR140	AFXR180
D1	50	68	85	120	165	215
D2	3.4	5.5	6.8	9	11	13
D3	12 _{j6}	16 _{h6}	22 _{h6}	32 _{h6}	40 _{h6}	55 _{h6}
D4 g6	35	60	70	90	130	160
D5	22	21	30	40	75	95
D6	M4 x 0.7P	M5 x 0.8P	M8 x 1.25P	M12 x 1.75P	M16 x 2P	M20 x 2.5P
D7 h6	-	16	22	32	40	55
L1	42	62	76	105	142	180
L2	19.5	28.5	36.5	58	82	82
L3	6.5	20	19.5	30	30	30
L4	1	1.5	1.5	2	3	3
L5	14	25	32	40	63	70
L6	2	2	3	5	5	6
L7	4	6	7	10	12	15
L8	111.5	171.5	216.5	283.5	360.5	427.5
L9	42	70	90	115	142	180
L10	10	12.5	19	28	36	42
L11	-	26	26	26	40	41.5
L12	-	15	15	15	20	21.5
L13	-	21	22.5	23	33.5	33.5
C1 ¹	46	70	100	130	165	215
C2 ¹	M4 x 0.7P	M5 x 0.8P	M6 x 1P	M8 x 1.25P	M10 x 1.5P	M12 x 1.75P
C3 ¹	≤11 / ≤12	≤14 / ≤16	≤19 / ≤24	≤32	≤38	≤48
C4 ¹	25	34	40	50	60	85
C5 ¹	30	50	80	110	130	180
C6 ¹	3.5	8	4	5	6	6
C7 ¹	42	60	90	115	142	190
C8 ¹	29.5	19	17	19.5	22.5	29
C9 ¹	90.5	116.5	152.5	191.5	235.5	303.5
C10 ¹	8.75	13.5	10.75	13	15	20.75
B1 h9	4	5	6	10	12	16
H1	13.5	18	24.5	35	43	59
X DIN5480	-	W16x0.8x 30x18x6m	W22x1.25x 30x16x6m	W32x1.25x 30x24x6m	W40x2x 30x18x6m	W55x2x 30x26x6m

1. C1~C10 are motor specific dimensions (metric std shown). Refer to www.apexdyna.com and Design Tool to view your specific motor mounting system.

Dimensions (2-stage, Ratio $i=15\sim 200$) / AFXR Series

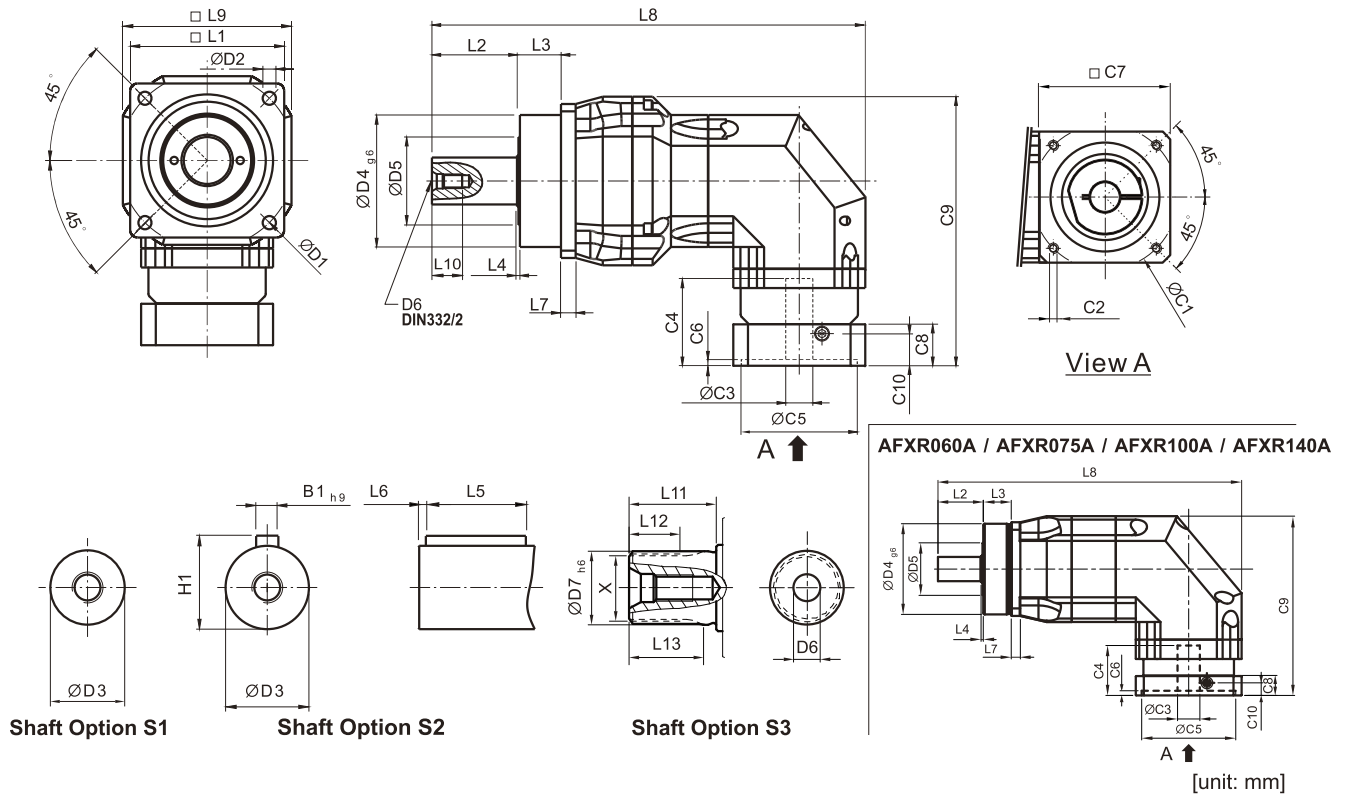

[unit: mm]

Dimension	AFXR042	AFXR060	AFXR060A	AFXR075	AFXR075A	AFXR100	AFXR100A	AFXR140	AFXR140A	AFXR180
D1	50	68		85		120		165		215
D2	3.4	5.5		6.8		9		11		13
D3	12 _{j6}	16 _{h6}		22 _{h6}		32 _{h6}		40 _{h6}		55 _{h6}
D4 _{g6}	35	60		70		90		130		160
D5	22	21		30		40		75		95
D6	M4x0.7P	M5x0.8P		M8x1.25P		M12x1.75P		M16x2P		M20x2.5P
D7 _{h6}	-	16		22		32		40		55
L1	42	62		76		105		142		180
L2	19.5	28.5		36.5		58		82		82
L3	6.5	20		19.5		30		30		30
L4	1	1.5		1.5		2		3		3
L5	14	25		32		40		63		70
L6	2	2		3		5		5		6
L7	4	6		7		10		12		15
L8	139	176	208.5	220	264.5	309.5	344.5	392.5	432	464.5
L9	42	70		90		115		142		180
L10	10	12.5		19		28		36		42
L11	-	26		26		26		40		41.5
L12	-	15		15		15		20		21.5
L13	-	21		22.5		23		33.5		33.5
C1 ²	46	46	70	70	100	100	130	130	165	165
C2 ²	M4x0.7P	M4x0.7P	M5x0.8P	M5x0.8P	M6x1P	M6x1P	M8x1.25P	M8x1.25P	M10x1.5P	M10x1.5P
C3 ²	≤11/≤12	≤11/≤12	≤14/≤16	≤14/≤15.875/≤16	≤19/≤24	≤19/≤24	≤32	≤32	≤38	≤38
C4 ²	25	25	34	34	40	40	50	50	60	60
C5 ²	30	30	50	50	80	80	110	110	130	130
C6 ²	3.5	3.5	8	8	4	4	5	5	6	6
C7 ²	42	42	60	60	90	90	115	115	142	142
C8 ²	29.5	29.5	19	19	17	17	19.5	19.5	22.5	22.5
C9 ²	90.5	104.5	116.5	126.5	152.5	165	191.5	205	235.5	254.5
C10 ²	8.75	8.75	13.5	13.5	10.75	10.75	13	13	15	15
B1 _{h9}	4	5		6		10		12		16
H1	13.5	18		24.5		35		43		59
X DIN5480	-	W16x0.8x 30x18x6m		W22x1.25x 30x16x6m		W32x1.25x 30x24x6m		W40x2x 30x18x6m		W55x2x 30x26x6m

2. C1~C10 are motor specific dimensions (metric std shown). Refer to www.apexdyna.com and Design Tool to view your specific motor mounting system.

Selection of the Optimum Gearbox

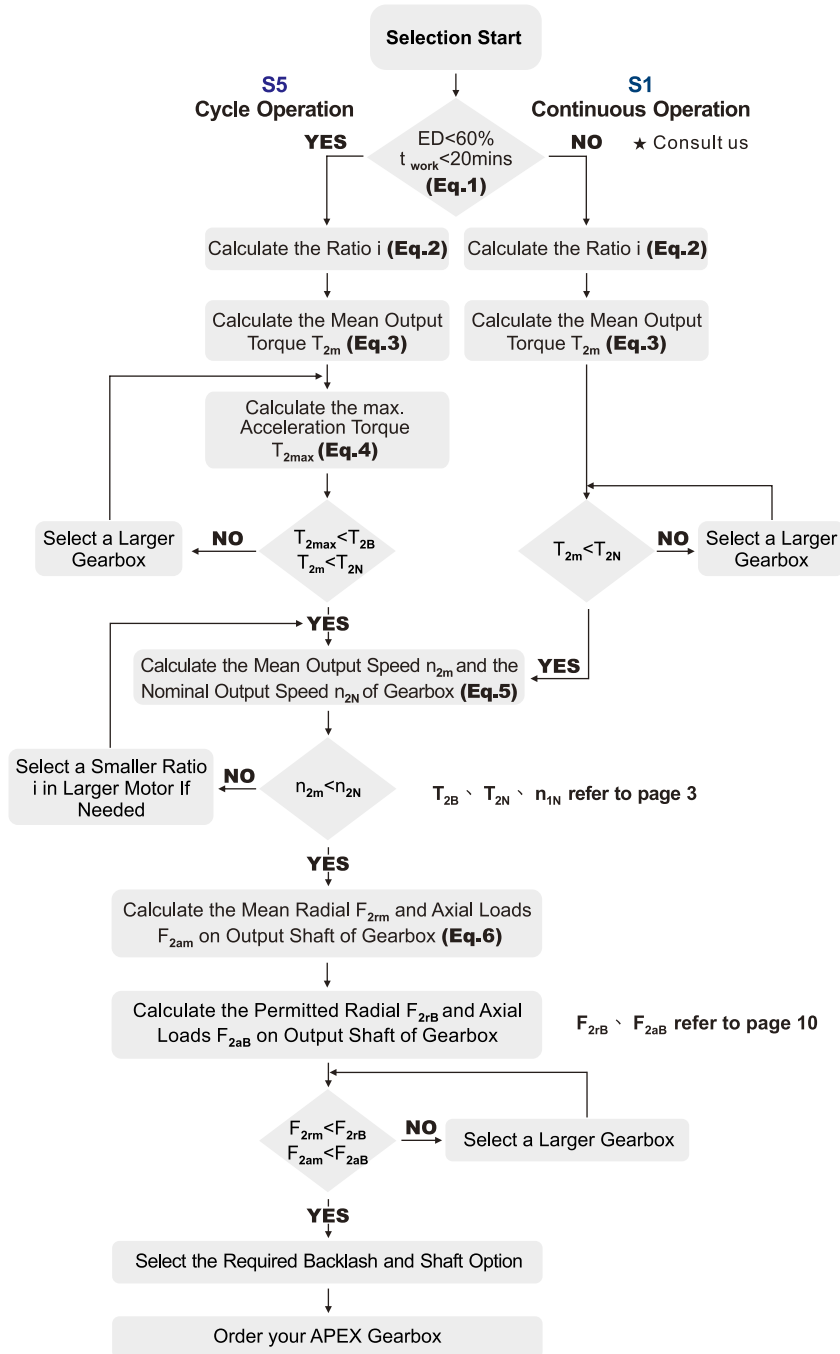

Recommended (for S5 Cycle Operation)

The general design is given for

$$\frac{J_L}{i^2} \leq 4 \times J_m$$

The optimal design is given for

$$\frac{J_L}{i^2} \cong J_m$$

J_L Load Inertia
 J_m Motor Inertia

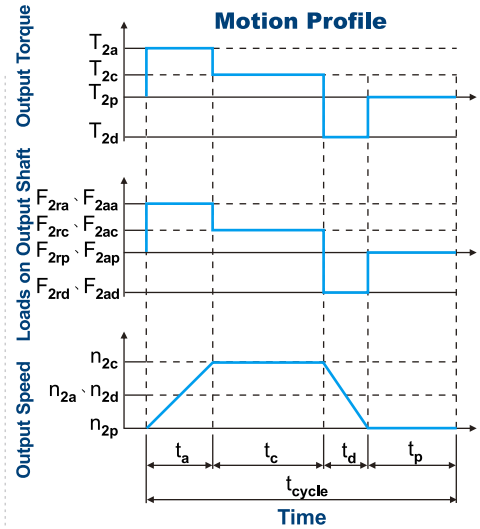

$$1. ED = \frac{t_a + t_c + t_d}{t_{cycle}} \times 100\%, t_{work} = t_a + t_c + t_d$$

Index : a. Acceleration, c. Constant, d. Deceleration, p. Pause (Eq.1)

$$2. i \cong \frac{n_m}{n_{work}}$$

n_m Output Speed of the Motor
 n_{work} Working Speed (Eq.2)

$$3. T_{2m} = \sqrt[3]{\frac{n_{2a} \times t_a \times T_{2a}^3 + n_{2c} \times t_c \times T_{2c}^3 + n_{2d} \times t_d \times T_{2d}^3}{n_{2a} \times t_a + n_{2c} \times t_c + n_{2d} \times t_d}}$$

(Eq.3)

$$4. T_{2max} = T_{mB} \times i \times k_s \times \eta$$

where K_s is

K_s	No. of Cycles / hr
1.0	0~1,000
1.1	1,000 ~ 1,500
1.3	1,500 ~ 2,000
1.6	2,000 ~ 3,000
1.8	3,000 ~ 5,000
2.0	5,000 ~ 9,000
2.05	9,000 ~ 10,000
not recommended	above 10,000

T_{mB} Max. Output Torque of the Motor

η Efficiency of the Gearbox (Eq.4)

$$5. n_{2a} = n_{2d} = \frac{1}{2} \times n_{2c}$$

$$n_{2m} = \frac{n_{2a} \times t_a + n_{2c} \times t_c + n_{2d} \times t_d}{t_a + t_c + t_d}$$

$$n_{2N} = \frac{n_{1N}}{i}$$

(Eq.5)

$$6. F_{2rm} = \sqrt[3]{\frac{n_{2a} \times t_a \times F_{2ra}^3 + n_{2c} \times t_c \times F_{2rc}^3 + n_{2d} \times t_d \times F_{2rd}^3}{n_{2a} \times t_a + n_{2c} \times t_c + n_{2d} \times t_d}}$$

$$F_{2am} = \sqrt[3]{\frac{n_{2a} \times t_a \times F_{2aa}^3 + n_{2c} \times t_c \times F_{2ac}^3 + n_{2d} \times t_d \times F_{2ad}^3}{n_{2a} \times t_a + n_{2c} \times t_c + n_{2d} \times t_d}}$$

(Eq.6)

Permitted Radial and Axial Loads

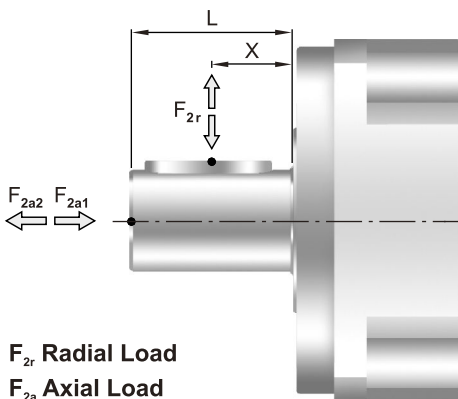

The permitted radial and axial loads on output shaft of the gearbox depend on the design of the gearbox supporting bearings. APEX use the extension straddle oversized ball bearing design. It can take heavy load from both axes.

F_{2r} Radial Load
 F_{2a} Axial Load

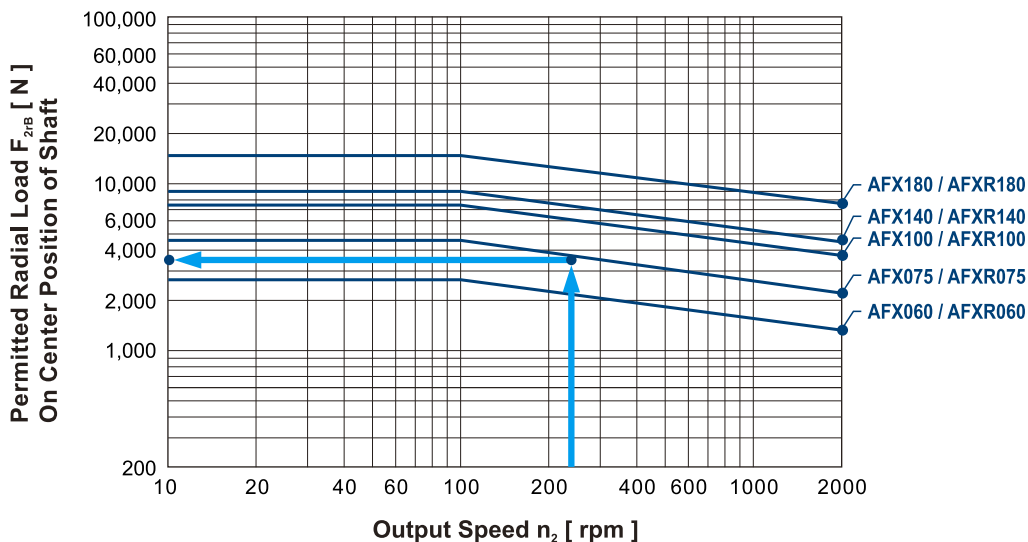

If radial force F_{2r} is exerted on the center of the output shaft $X=1/2 \times L$. The permitted radial load is given on left diagram.

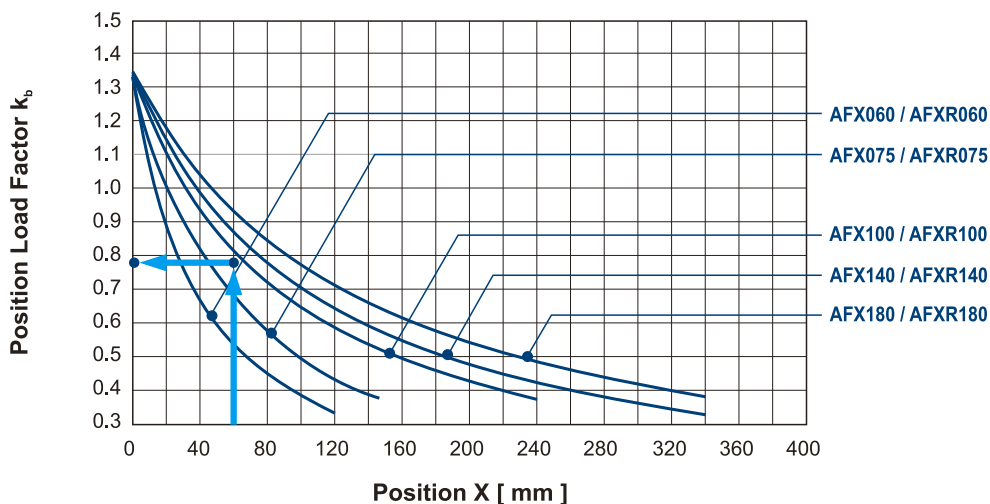

If radial force F_{2r} is not exerted on the center of the output shaft $X < 1/2 \times L$ or $X > 1/2 \times L$. The permitted radial and axial loads can be calculated by the position load factor k_b on the left diagram.

Note

Note



**APEX TAIWAN NORTH
ANDTEK AUTOMATION CO.,LTD**
TEL +886-02-82262655
13F-5, No.2, Jian 8th Rd., Jhonghe Dist., New
Taipei City 235, TAIWAN
sales@andtek.com.tw
www.apexdyna.com



**APEX TAIWAN CENTRAL
ANDTEK AUTOMATION CO.,LTD**
TEL +886-04-23594286
9F-6, No.925, Sec.4, Taiwan Blvd., Xitun Dist.
Taichung City 407 TAIWAN
sales@andtek.com.tw
www.apexdyna.com



**APEX TAIWAN SOUTH
MEN JENN ELECTRIC CO., LTD.**
TEL +886-06-2337332 ~ 6
No.774, Zhonghua Rd., Yongkang Dist., Tainan
City 710, TAIWAN
menjenn@ms24.hinet.net
www.apexdyna.com



APEX DYNAMICS INC. SHANGHAI
TEL +86-21-69220577
No.128 ZHUUYING Road QINGPU Industry Area,
Shanghai, CHINA
sales@apexdyna.cn
www.apexdyna.cn



APEX DYNAMICS SHENZHEN, LTD.
TEL +86-755-84516325
No. 1102A of D area , CFG mansion ,Bao Yuan
Road , Bao'an District , Shenzhen ,CHINA.
sales@szapexdyna.com
www.szapexdyna.com



APEX DYNAMICS BEIJING, LTD.
TEL +86-10-69570691
NO.1,YaoPingRoad,SongZhuang Town, Tongzhou
istrict, Beijing, CHINA.
bjapexdyna@163.com
www.bjapex.cn



CHONGQING APEX DYNAMICS CO., LTD.
TEL +86-23-67686860
406, Building 5, No.68, Jinyu Avenue, Beibu New
Area, Chongqing, CHINA
sales@cqapexdyna.com
www.apexdyna.com



APEX (XIAMEN) DYNAMICS TECHNOLOGY CO., LTD.
TEL +86-0592-720-5279
Unit B-3, 1F., No.129, Jingquan Road, Jimei District,
Xiamen, Fujian, CHINA
sales@xmmapexdyna.com
www.xmmapexdyna.com



APEX DYNAMICS USA, INC.
TEL +1-631-2449040
885 Marconi Avenue Ronkonkoma, NY 11779
U.S.A.
sales@apexdynamicsusa.com
www.apexdynamicsusa.com



APEX DYNAMICS KOREA
TEL +82-31-8179992
1246-32, Seongsuk-dong, Ilsandong-gu, Goyang-city,
Gyeonggi-Do, KOREA (R.O.K) 410-570
sales@apexdynakorea.co.kr
www.apexdynakorea.co.kr



APEX DYNAMICS JAPAN
TEL +86-092-4511202
1-3-46, Hamnichibasi, Hakata-ku, Fukuoka,
812-0897, JAPAN
sales@apexdyna.jp
www.apexdyna.jp



APEX DYNAMICS SINGAPORE PTE LTD
TEL +65-62-626228
3 South Buona Vista Road, #05-15 & #06-15.
SINGAPORE 118136
sales@apexdyna.com.sg
www.apexdyna.com.sg



APEX DYNAMICS (THAILAND) CO., LTD.
TEL +66-2-3266233
73 Soi Ladkrabang 30, Kadkrabang Rd., Bangkok
10520, THAILAND
sales@apexdyna.co.th
www.apexdyna.co.th



APEX DYNAMICS BV
TEL +31-492-509995
Churchillaan 101 5705 BK Helmond, NETHERLANDS
sales@apexdyna.nl
www.apexdyna.be



**APEX DYNAMICS
POLSKA SP. Z O.O.**
TEL +48-12-6304728
Krakowska 50, 32-083 Balice, POLAND
sales@apexdyna.pl
www.apexdyna.pl



APEX DYNAMICS SPAIN, S.L.
TEL +34-93-6562990
Poligono Industrial Molí dels Frares, Calle C nº
12,08620 - Sant Vicenç dels Horts, Barcelona, SPAIN
apexdyna@apexdyna.es
www.apexdyna.es



LIMAN TRADING LIMITED FZC LLC
P.O. Box 97 , Postal Code 322, Corporate Parks,
Sohar Free Zoon, Oman



APEKS REDUKTOR VE DISLI SAN. TIC. LTD. STI.
TEL +90-232-4589960
10042 Sok.No:10 AOSB Çiğli-Izmir, TURKEY
sales@apexdyna.com.tr
www.apexdyna.com.tr



APEX DYNAMICS AUSTRALIA PTY LTD.
TEL +613-95-852739
36 Taunton Drive, Cheltenham, Victoria 3192
AUSTRALIA.
sales@apexdyna.com.au
www.apexdyna.com.au



APEX DYNAMICS (I) JV
TEL +91-80-55345541
GAT NO. 279, KHED SHIVAPUR BAUG, TALUKA
HAVELI PUNE- 412205 INDIA.
sales@apexdyna.co.in
www.apexdyna.co.in



APEX DYNAMICS FRANCE SAS
TEL +33-160-135097
11 - Burospace F - 91570 -
Bièvres, FRANCE
info@apexdyna.fr
www.apexdyna.fr



APEX DYNAMICS SWEDEN AB
TEL +46-75-2424444
Fredrikbergsgatan 2 SE-573 92 Tranås, SWEDEN
sales@apexdyna.se
www.apexdyna.se



PT.APEX DYNAMICS INDONESIA
TEL +62 21 2928 3681
Rukan Aralia Blok HY43 no.11, Harapan Indah II,
Bekasi - Jawa Barat, INDONESIA 17214
sales@apexdyna.co.id
www.apexdyna.co.id



APEX DYNAMICS GERMANY GMBH
TEL +49-7181-9329955
Spanninger Str. 9, 73650 Winterbach, GERMANY
Langer@apexdynamics.de
www.apexdynamics.de



APEX DYNAMICS CZECH S.R.O.
TEL +420-577-663877
tř. Tomáše Bati 1851 765 02 Otrokovice ČESKÁ
REPUBLIKA
info@apexdynaczech.cz
www.apexdynaczech.cz



APEX DYNAMICS РОССИЯ
TEL +7-495-2255452
+7-495-6462422
г.Москва, ул. Южнопортовая, дом 7, строение
"С", 3-й этаж
info@apexdynarussia.ru
www.apexdynarussia.ru



APEX DYNAMICS UK
TEL +44-0121-737-1170
Heath House, Cheadle Rd, Uttoxeter,
ST14 7BY, UK
mikeg@apexdynauk.com
www.apexdynauk.com



APEX DYNAMICS SWITZERLAND AG
TEL +41-55-4517020 Talstrasse 24, CH-8852
Altendorf, SWITZERLAND
info@apexdyna.ch
www.apexdyna.ch



APEX DYNAMICS MOTION SDN BHD
TEL +60 7237 1055
No.1, Jalan Perniagaan Setia 3, Taman
Perniagaan Setia, 81100 Johor Bahru, Johor,
MALAYSIA (Setia Business Park 2 @ Iskandar
Malaysia)
sales@apexdyna.com.sg
www.apexdyna.com.sg



APEX DYNAMICS BRAZIL
TEL +55-47-30298700
Rua Senador Petrônio Portela, 47 - Bloco 5, Zona
Industrial Norte - CEP 89218-575 - Joinville (SC)
lucan@neoyama.com.br
adriano.duarte@neoyama.com.br
www.neoyama.com.br



APEX DYNAMICS ITALY
TEL +39 02.36634521
VIA E. DE AMICIS, 2 – 20091 BRESSO (MI)
info@apexdynamics.it
www.apexdynamics.it



Apex Dynamics Austria GmbH
TEL +43 07207884160
Dr. Hans-Lechner-Strasse 6,
5071 Wals-Siezenheim
info@apexdynamics.at
www.apexdynamics.at



UAB "APEXO DINAMIKA"
TEL +370 52078165
Medaus g. 28A,
Medininku k., Vilniaus r. Sav.
LT-13192
info@apexdyna.lt



APEX DYNAMICS, INC.

No. 10, Keyuan 3rd Rd., Situn District, Taichung City 40763, Taiwan (R.O.C.)
Tel:886-4-24650219 | Fax:886-4-24650118
sales@apexdyna.com | http://www.apexdyna.com

