



**APEX DYNAMICS, INC.**

**HIGH PRECISION  
HIGH SPEED  
PLANETARY GEARBOX**

**AD / ADR / ADS Series**



**Stainless**



**APEX DYNAMICS, INC.**



**Apex Dynamics, Inc.** is the world's most productive manufacturer of servomotor drive planetary gearboxes for precision automation machinery. From our 800,000+ square foot ISO 9001:2008 manufacturing facility, based in Taichung, Taiwan, we manufacture to stock using the newest precision machine tools and quality test and inspection equipment. Complete focus on quality and precision allows us to produce our high quality gearheads at precision levels down to less than 1 arc minute (1/60 th of a degree), with consistency and high reliability.

Based on more than twenty years of accumulated manufacturing and marketing experience, plus the highest level of technical production capabilities, Apex Dynamics, Inc. designs and builds technically advanced, high speed, low backlash servo application planetary gearboxes. Our Break through patented technology (over 6 patents), provides the customer with the optimum high precision helical reducer at a reasonable price. We are continuously improving processes, finding proper and effective methods to provide customers new solutions for difficult applications, and developing new products.

The primary focus in daily operation is quality. We pride ourselves on our dedication to quality; our duty - is customer satisfaction.



**APEX**



# AD Series Ordering Code

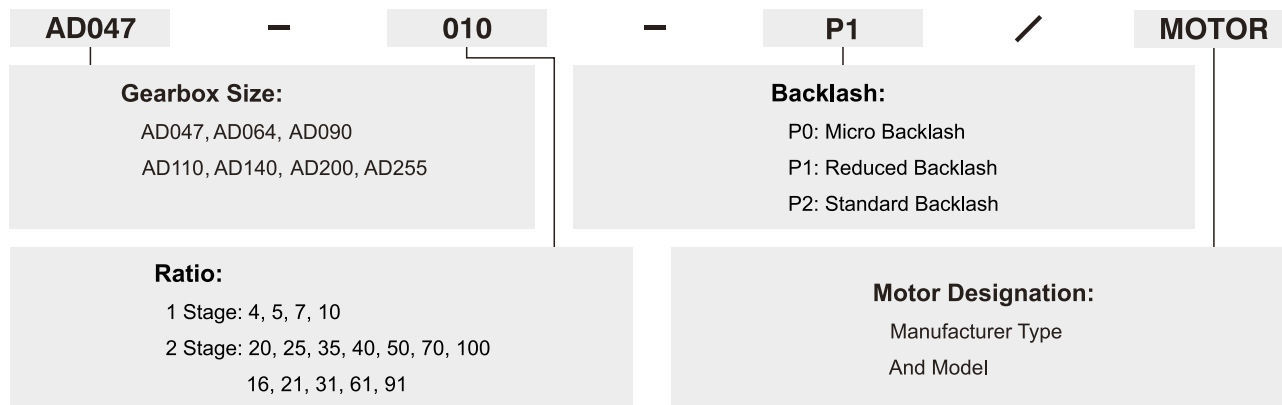

**Ordering Example: AD047-010-P1 / SIEMENS 1FT6 041-4AF71**

# ADR Series Ordering Code

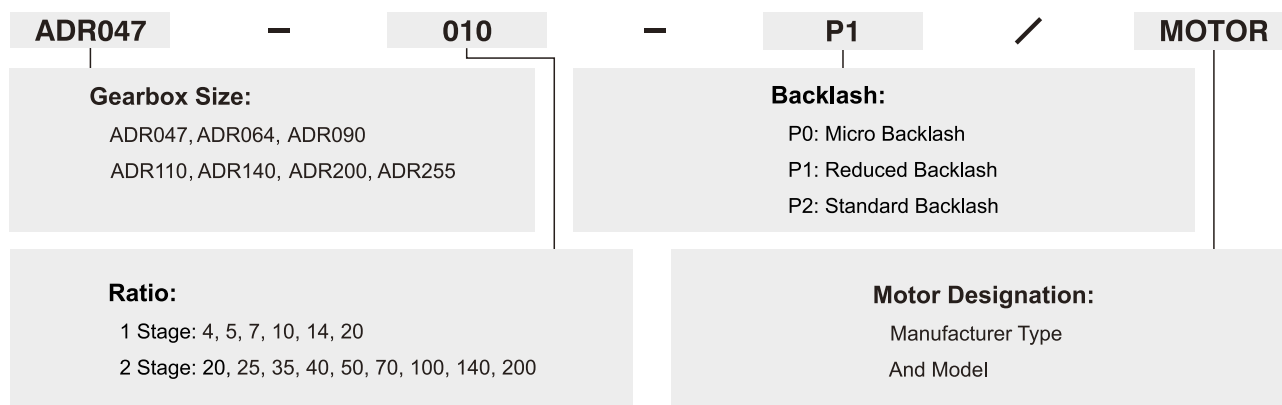

**Ordering Example: ADR047-010-P1 / SIEMENS 1FT5 034-OAK71**

# ADS Series Ordering Code

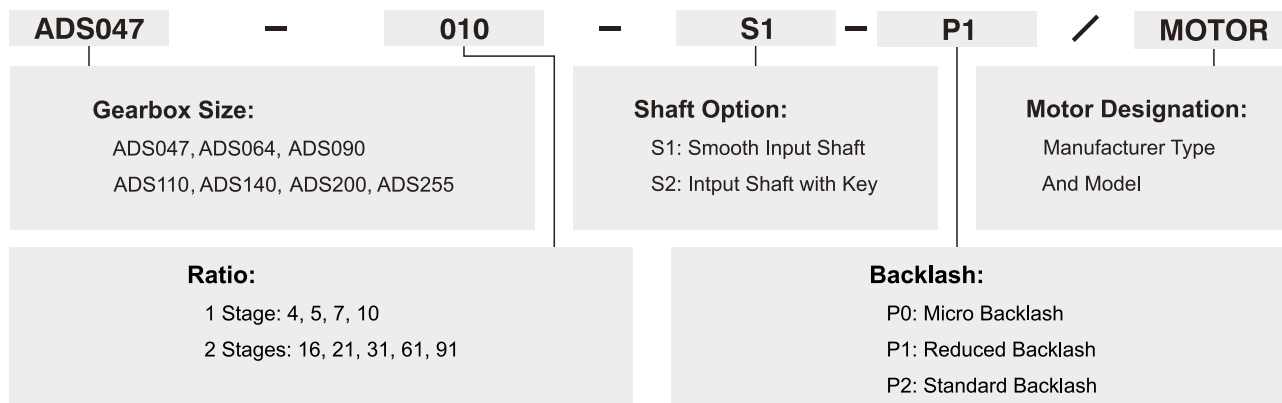

**Ordering Example: ADS047-010-S1-P1 / SIEMENS 1FT5 034-OAK71**



©2019 by APEX DYNAMICS, INC.  
 APEX DYNAMICS, INC. reserves modification and copyrights of all technical specifications, illustrations and drawings in this catalog in allowance for continuous products development and advancement.  
 For the newest data and information, please visit <http://www.apexdyna.com/>

# Specifications / AD Series

## Gearbox Performance

Model No.		Stage	Ratio <sup>(1)</sup>	AD047	AD064	AD090	AD110	AD140	AD200	AD255			
Nominal Output Torque $T_{2N}$	Nm	1	4	19	48	130	270	560	1,100	1,700			
			5	22	60	160	330	650	1,200	2,000			
			7	19	50	140	300	550	1,100	1,800			
			10	14	40	100	230	450	900	1,500			
		2	20	19	48	130	270	560	1,100	1,700			
			25	22	60	160	330	650	1,200	2,000			
			35	19	50	140	300	550	1,100	1,800			
			40	19	48	130	270	560	1,100	1,700			
			50	22	60	160	330	650	1,200	2,000			
			70	19	50	140	300	550	1,100	1,800			
			100	14	40	100	230	450	900	1,500			
			16	19	48	130	270	560	1,100	1,700			
			21	22	60	160	330	650	1,200	2,000			
			31	19	50	140	300	550	1,100	1,800			
			61	19	50	140	300	550	1,100	1,800			
			91	14	40	100	230	450	900	1,500			
			Emergency Stop Torque $T_{2NOT}^{(2)}$	Nm	1,2	4~100	3 times of Nominal Output Torque						
			Nominal Input Speed $n_{iN}$	rpm	1,2	4~100	5,000	5,000	4,000	4,000	3,000	3,000	2,000
Max. Input Speed $n_{iB}$	rpm	1,2	4~100	10,000	10,000	8,000	8,000	6,000	6,000	4,000			
Micro Backlash P0	arcmin	1	4~10	-	-	≤1	≤1	≤1	≤1	≤1			
		2	20~100	-	-	-	≤3	≤3	≤3	≤3			
Reduced Backlash P1	arcmin	1	4~10	≤3	≤3	≤3	≤3	≤3	≤3	≤3			
		2	20~100	≤5	≤5	≤5	≤5	≤5	≤5	≤5			
Standard Backlash P2	arcmin	1	4~10	≤5	≤5	≤5	≤5	≤5	≤5	≤5			
		2	20~100	≤7	≤7	≤7	≤7	≤7	≤7	≤7			
Torsional Rigidity	Nm/arcmin	1,2	4~100	7	13	31	82	151	440	1,006			
Max. Tilting Moment $M_{2K}$	Nm	1,2	4~100	55	75	190	300	1,300	2,930	5,500			
Max. Axial Load $F_{2AB}^{(3)}$	N	1,2	4~100	990	1,050	2,850	2,990	10,590	16,660	29,430			
Efficiency $\eta$	%	1	4~10	≥97%									
		2	20~100	≥94%									
Weight	kg	1	4~10	0.7	1.2	3.0	5.6	11.9	31.6	56.1			
		2	20~100	1.0	1.6	3.7	7.3	15.9	36.9	70.4			
Operating Temp	°C	1,2	4~100	-10°C~90°C									
Lubrication				Synthetic lubrication oils									
IP Level		1,2	4~100	IP65									
Mounting Position		1,2	4~100	all directions									
Noise <sup>(4)</sup>	dB(A)	1,2	4~100	≤56	≤58	≤60	≤63	≤65	≤67	≤70			

## Gearbox Inertia

Model No.		Stage	Ratio <sup>(1)</sup>	AD047	AD064	AD090	AD110	AD140	AD200	AD255
Moments of Inertia $J_i$	kg · cm <sup>2</sup>	1	4	0.03	0.14	0.51	2.87	7.54	25.03	58.31
			5	0.03	0.13	0.47	2.71	7.42	23.29	53.27
			7	0.03	0.13	0.45	2.62	7.14	22.48	50.97
			10	0.03	0.13	0.44	2.57	7.03	22.51	50.56
		2	20	0.03	0.03	0.13	0.47	2.71	7.42	23.29
			25	0.03	0.03	0.13	0.47	2.71	7.42	23.29
			35	0.03	0.03	0.13	0.47	2.71	7.42	23.29
			40	0.03	0.03	0.13	0.44	2.57	7.03	22.51
			50	0.03	0.03	0.13	0.44	2.57	7.03	22.51
			70	0.03	0.03	0.13	0.44	2.57	7.03	22.51
			100	0.03	0.03	0.13	0.44	2.57	7.03	22.51
			16	0.03	0.03	0.13	0.47	2.71	7.42	23.29
			21	0.03	0.03	0.13	0.47	2.71	7.42	23.29
			31	0.03	0.03	0.13	0.44	2.57	7.03	22.51
			61	0.03	0.03	0.13	0.44	2.57	7.03	22.51
			91	0.03	0.03	0.13	0.44	2.57	7.03	22.51

(1) Ratio ( $i=N_{in}/N_{out}$ )(2) Max. acceleration torque  $T_{2B} = 60\%$  of  $T_{2NOT}$ 

(3) Applied to the output shaft center at 100 rpm

(4) The dB values are measured by gearbox with ratio 10 (1-stage) or ratio 100 (2-stage), no loading at 3,000 RPM or at the respective Nominal Input Speed by bigger model size.

By lower ratio and/or higher RPM, the noise level could be 3 to 5 dB higher.

# Dimensions (1-stage, Ratio $i=4\sim 10$ ) / AD Series

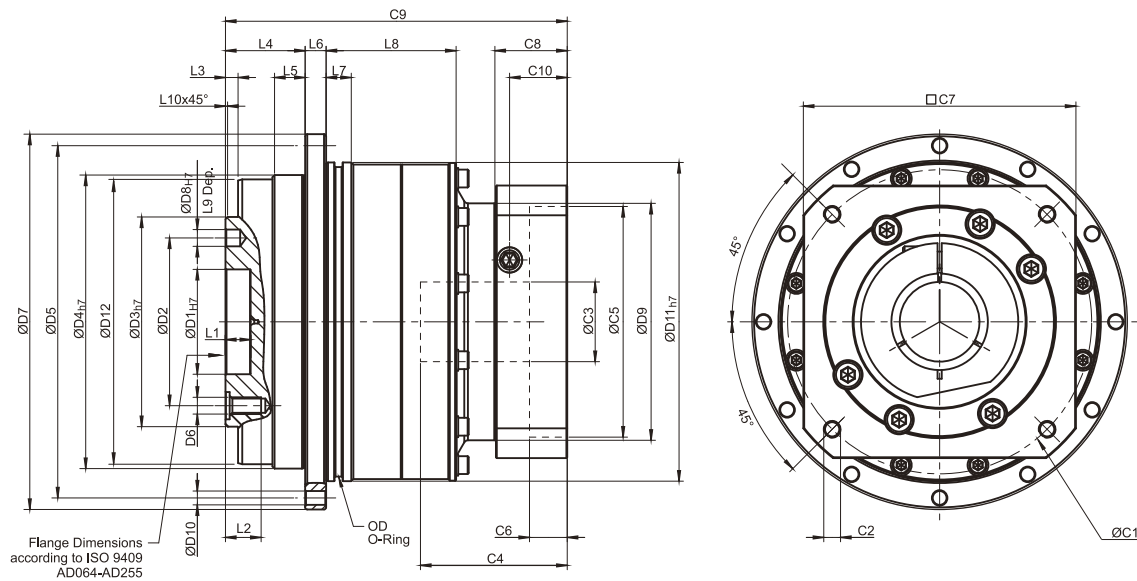

[unit: mm]

Dimension	AD047	AD064	AD090	AD110	AD140	AD200	AD255
D1 <sub>H7</sub>	12	20	31.5	40	50	80	100
D2	20	31.5	50	63	80	125	140
D3 <sub>h7</sub>	28	40	63	80	100	160	180
D4 <sub>h7</sub>	47	64	90	110	140	200	255
D5	67	79	109	135	168	233	280
D6	4 x M3 x 0.5P	7 x M5 x 0.8P	7 x M6 x 1P	11 x M6 x 1P	11 x M8 x 1.25P	11 x M10 x 1.5P	12 x M16 x 2P
D7	72	86	118	145	179	247	300
D8 <sub>H7</sub>	3	5	6	6	8	10	12
D9	45.5	55	77	90	113	138	175
D10	8 x 3.4	8 x 4.5	8 x 5.5	8 x 5.5	12 x 6.6	12 x 9	16 x 13.5
D11 <sub>h7</sub>	60	70	95	120	152	212	255
D12	46.2	63.2	89.2	109.2	139.2	199.2	254.2
L1	4	8	12	12	12	16	20
L2	6.5	8	13.5	13.5	17	22.5	30.5
L3	3	3	6	6	6	8	12
L4	19.5	19.5	30	29	38	50	66
L5	7	7	10	10	14.6	15	20
L6	4	4	7	8	10	12	18
L7	5	7.7	8	10	12	15	20
L8	18.5	28.5	27	37	62	69.5	82
L9	4	6	7	7	7	10	10
L10	0.5	0.5	1	1	1	1	1
C1 <sup>1</sup>	46	70	100	130	165	215	235
C2 <sup>1</sup>	M4 x 0.7P	M5 x 0.8P	M6 x 1P	M8 x 1.25P	M10 x 1.5P	M12 x 1.75P	M12 x 1.75P
C3 <sup>1</sup>	≤11 / ≤12 <sup>2</sup>	≤14 / ≤16 <sup>2</sup>	≤19 / ≤24	≤32	≤38	≤48	≤55
C4 <sup>1</sup>	30	34	40	50	60	85	116
C5 <sup>1</sup>	30	50	80	110	130	180	200
C6 <sup>1</sup>	3.5	8	4	5	6	6	6
C7 <sup>1</sup>	48	60	90	115	142	190	220
C8 <sup>1</sup>	19.5	19	17	19.5	22.5	29	63
C9 <sup>1</sup>	70	82.5	99.5	121.5	151	199.5	256.5
C10 <sup>1</sup>	13.25	13.5	10.75	13	15	20.75	53.5
OD	56 x 2	66 x 2	90 x 3	110 x 3	145 x 3	200 x 5	238 x 5

1. C1~C10 are motor specific dimensions (metric std shown). Refer to [www.apexdyna.com](http://www.apexdyna.com) and Design Tool to view your specific motor mounting system.  
 2. AD047 ratio 5, 10 offers C3 ≤ 12 option; AD064 ratio 5, 10 offers C3 ≤ 16 option.

# Dimensions (2-stage, Ratio $i=20\sim 100$ ) / AD Series

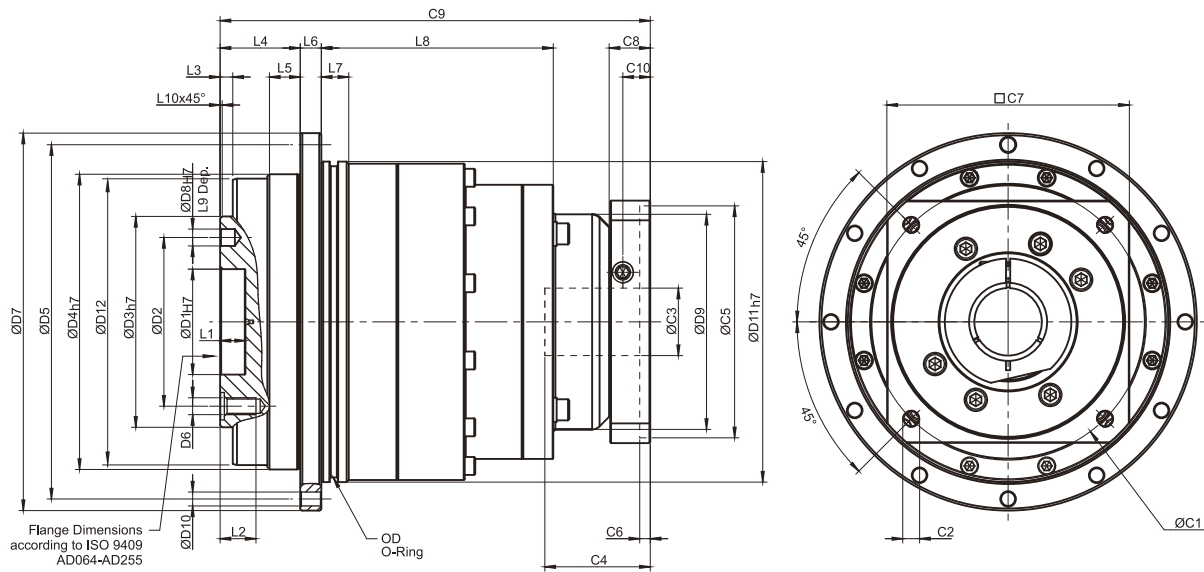

[unit: mm]

Dimension	AD047	AD064	AD090	AD110	AD140	AD200	AD255
D1 <sub>H7</sub>	12	20	31.5	40	50	80	100
D2	20	31.5	50	63	80	125	140
D3 <sub>h7</sub>	28	40	63	80	100	160	180
D4 <sub>h7</sub>	47	64	90	110	140	200	255
D5	67	79	109	135	168	233	280
D6	4 x M3 x 0.5P	7 x M5 x 0.8P	7 x M6 x 1P	11 x M6 x 1P	11 x M8 x 1.25P	11 x M10 x 1.5P	12 x M16 x 2P
D7	72	86	118	145	179	247	300
D8 <sub>H7</sub>	3	5	6	6	8	10	12
D9	45.5	45.5	53.4	77	102	125	160
D10	8 x 3.4	8 x 4.5	8 x 5.5	8 x 5.5	12 x 6.6	12 x 9	16 x 13.5
D11 <sub>h7</sub>	60	70	95	120	152	212	255
D12	46.2	63.2	89.2	109.2	139.2	199.2	254.2
L1	4	8	12	12	12	16	20
L2	6.5	8	13.5	13.5	17	22.5	30.5
L3	3	3	6	6	6	8	12
L4	19.5	19.5	30	29	38	50	66
L5	7	7	10	10	14.6	15	20
L6	4	4	7	8	10	12	18
L7	5	7.7	8	10	12	15	20
L8	54.5	65	60	87.5	110	132.5	148
L9	4	6	7	7	7	10	10
L10	0.5	0.5	1	1	1	1	1
C1 <sup>3</sup>	46	46	70	100	130	165	215
C2 <sup>3</sup>	M4 x 0.7P	M4 x 0.7P	M5 x 0.8P	M6 x 1P	M8 x 1.25P	M10 x 1.5P	M12 x 1.75P
C3 <sup>3</sup>	≤11 / ≤12	≤11 / ≤12	≤14 / ≤15.875 / ≤16	≤19 / ≤24	≤32	≤38	≤48
C4 <sup>3</sup>	30	30	34	40	50	60	85
C5 <sup>3</sup>	30	30	50	80	110	130	180
C6 <sup>3</sup>	3.5	3.5	8	4	5	6	6
C7 <sup>3</sup>	48	48	60	90	115	142	190
C8 <sup>3</sup>	19.5	19.5	19	17	19.5	22.5	29
C9 <sup>3</sup>	97.5	108	134	160	204	248	311.5
C10 <sup>3</sup>	13.25	13.25	13.5	10.75	13	15	20.75
OD	56 x 2	66 x 2	90 x 3	110 x 3	145 x 3	200 x 5	238 x 5

3. C1-C10 are motor specific dimensions (metric std shown). Refer to [www.apexdyna.com](http://www.apexdyna.com) and Design Tool to view your specific motor mounting system.

# Dimensions (2-stage, Ratio $i=16\sim91$ ) / AD Series

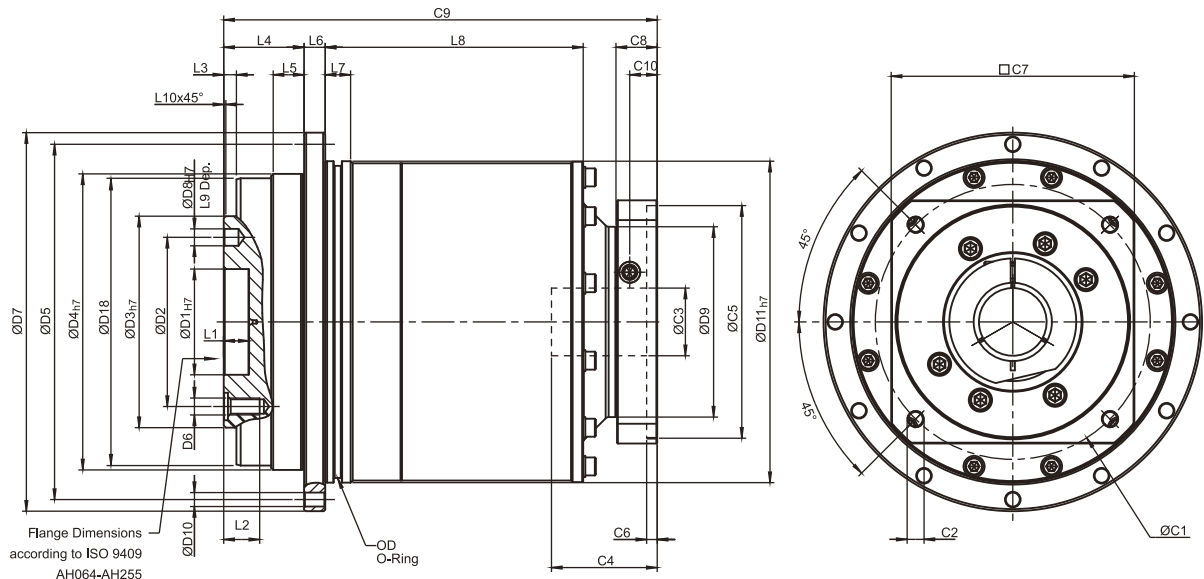

[unit: mm]

Dimension	AD047	AD064	AD090	AD110	AD140	AD200	AD255
D1 <sup>H7</sup>	12	20	31.5	40	50	80	100
D2	20	31.5	50	63	80	125	140
D3 <sup>h7</sup>	28	40	63	80	100	160	180
D4 <sup>h7</sup>	47	64	90	110	140	200	255
D5	67	79	109	135	168	233	280
D6	4 x M3 x 0.5P	7 x M5 x 0.8P	7 x M6 x 1P	11 x M6 x 1P	11 x M8 x 1.25P	11 x M10 x 1.5P	12 x M16 x 2P
D7	72	86	118	145	179	247	300
D8 <sup>H7</sup>	3	5	6	6	8	10	12
D9	45.5	45.5	55	77	90	113	138
D10	8 x 3.4	8 x 4.5	8 x 5.5	8 x 5.5	12 x 6.6	12 x 9	16 x 13.5
D11 <sup>h7</sup>	60	70	95	120	152	212	255
D18	46.2	63.2	89.2	109.2	139.2	199.2	254.2
L1	4	8	12	12	12	16	20
L2	6.5	8	13.5	13.5	17	22.5	30.5
L3	3	3	6	6	6	8	12
L4	19.5	19.5	30	29	38	50	66
L5	7	7	10	10	14.6	15	20
L6	4	4	7	8	10	12	18
L7	5	7.7	8	10	12	15	20
L8	52.5	28.5	32	37	122	79.5	82
L9	4	6	7	7	7	10	10
L10	0.5	0.5	1	1	1	1	1
C1 <sup>d</sup>	46	46	70	100	130	165	215
C2 <sup>d</sup>	M4 x 0.7P	M4 x 0.7P	M5 x 0.8P	M6 x 1P	M8 x 1.25P	M10 x 1.5P	M12 x 1.75P
C3 <sup>d</sup>	≤11 / ≤12	≤11 / ≤12	≤14 / ≤15.875 / ≤16	≤19 / ≤24	≤32	≤38	≤48
C4 <sup>d</sup>	30	30	34	40	50	60	85
C5 <sup>d</sup>	30	30	50	80	110	130	180
C6 <sup>d</sup>	3.5	3.5	8	4	5	6	6
C7 <sup>d</sup>	48	48	60	90	115	142	190
C8 <sup>d</sup>	19.5	19.5	19	17	19.5	22.5	29
C9 <sup>d</sup>	100	106	130.5	149	205	247.5	323
C10 <sup>d</sup>	13.25	13.25	13.5	10.75	13	15	20.75
OD	56 x 2	66 x 2	90 x 3	110 x 3	145 x 3	200 x 5	238 x 5

4. C1~C10 are motor specific dimensions (metric std shown). Refer to [www.apexdyna.com](http://www.apexdyna.com) and Design Tool to view your specific motor mounting system.

# Specifications / ADR Series

## Gearbox Performance

Model No.		Stage	Ratio <sup>(1)</sup>	ADR047	ADR064	ADR090	ADR110	ADR140	ADR200	ADR255	
Nominal Output Torque $T_{2N}$	Nm	1	4	19	48	130	270	560	1,100	1,700	
			5	22	60	160	330	650	1,200	2,000	
			7	19	50	140	300	550	1,100	1,800	
			10	14	60	160	325	650	1,200	2,000	
			14	-	42	140	300	550	1,100	1,800	
			20	-	40	100	230	450	900	1,500	
		2	20	19	-	-	-	-	-	-	-
			25	22	60	160	330	650	1,200	2,000	
			35	19	50	140	300	550	1,100	1,800	
			40	19	48	130	270	560	1,100	1,700	
			50	22	60	160	330	650	1,200	2,000	
			70	19	50	140	300	550	1,100	1,800	
			100	14	40	100	230	450	900	1,500	
			140	-	-	140	300	550	1,100	1,800	
200	-	-	100	230	450	900	1,500				
Emergency Stop Torque $T_{2NOTB}$ <sup>(2)</sup>	Nm	1,2	4~200	3 times of Nominal Output Torque							
Nominal Input Speed $n_{1N}$	rpm	1,2	4~200	5,000	5,000	4,000	4,000	3,000	3,000	2,000	
Max. Input Speed $n_{1B}$	rpm	1,2	4~200	10,000	10,000	8,000	8,000	6,000	6,000	4,000	
Micro Backlash P0	arcmin	1	4~20	-	-	≤2	≤2	≤2	≤2	≤2	
		2	25~200	-	-	≤4	≤4	≤4	≤4	≤4	
Reduced Backlash P1	arcmin	1	4~20	≤4	≤4	≤4	≤4	≤4	≤4	≤4	
		2	25~200	≤7	≤7	≤7	≤7	≤7	≤7	≤7	
Standard Backlash P2	arcmin	1	4~20	≤6	≤6	≤6	≤6	≤6	≤6	≤6	
		2	25~200	≤9	≤9	≤9	≤9	≤9	≤9	≤9	
Torsional Rigidity	Nm/arcmin	1,2	4~200	7	13	31	82	151	440	1,006	
Max. Tilting Moment $M_{2K}$	Nm	1,2	4~200	55	75	190	300	1,300	2,930	5,500	
Max. Axial Load $F_{2aB}$ <sup>(3)</sup>	N	1,2	4~200	990	1,050	2,850	2,990	10,590	16,660	29,430	
Efficiency $\eta$	%	1	4~20	≥95%							
		2	25~200	≥92%							
Weight	kg	1	4~20	1.1	2.1	5.9	10.5	21.9	50.9	85.4	
		2	25~200	1.4	1.9	4.5	9.8	20.1	45.4	85.9	
Operating Temp	°C	1,2	4~200	-10°C~90°C							
Lubrication				Synthetic lubrication oils							
IP Level		1,2	4~200	IP65							
Mounting Position		1,2	4~200	all directions							
Noise <sup>(4)</sup>	dB(A)	1,2	4~200	≤61	≤63	≤65	≤68	≤70	≤72	≤74	

## Gearbox Inertia

Model No.		Stage	Ratio <sup>(1)</sup>	ADR047	ADR064	ADR090	ADR110	ADR140	ADR200	ADR255
Moments of Inertia $J_i$	kg · cm <sup>2</sup>	1	4~10	0.09	0.35	2.25	6.84	23.4	68.9	135.4
			14	-	0.31	1.87	6.25	21.8	65.6	119.8
			20	-	0.31	1.87	6.25	21.8	65.6	119.8
		2	20	0.09	-	-	-	-	-	-
			25~100	0.09	0.09	0.35	2.25	6.84	23.4	68.9
			140~200	-	-	0.31	1.87	6.25	21.8	65.6

(1) Ratio ( $i=N_{in}/N_{out}$ )(2) Max. acceleration torque  $T_{2B} = 60\%$  of  $T_{2NOT}$ 

(3) Applied to the output shaft center at 100 rpm

(4) The dB values are measured by gearbox with ratio 10 (1-stage) or ratio 100 (2-stage), no loading at 3,000 RPM or at the respective Nominal Input Speed by bigger model size.

By lower ratio and/or higher RPM, the noise level could be 3 to 5 dB higher.



# Dimensions (1-stage, Ratio $i=4\sim 20$ ) / ADR Series

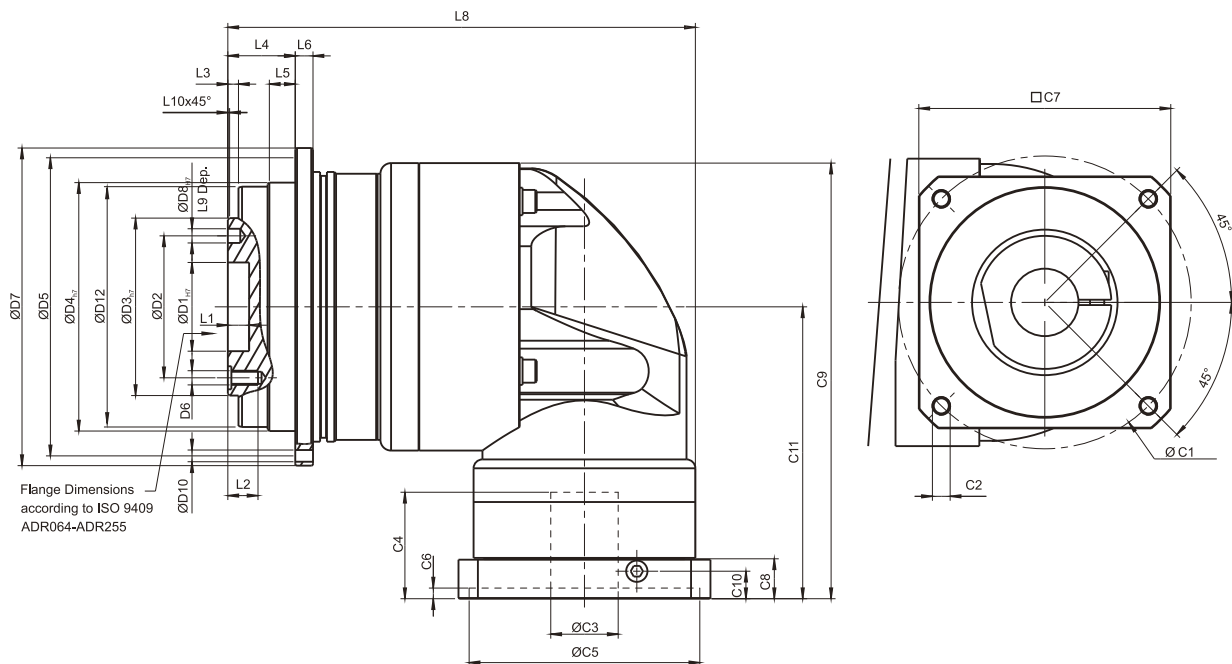

[unit: mm]

Dimension	ADR047	ADR064	ADR090	ADR110	ADR140	ADR200	ADR255
D1 <sub>H7</sub>	12	20	31.5	40	50	80	100
D2	20	31.5	50	63	80	125	140
D3 <sub>h7</sub>	28	40	63	80	100	160	180
D4 <sub>h7</sub>	47	64	90	110	140	200	255
D5	67	79	109	135	168	233	280
D6	4 x M3 x 0.5P	7 x M5 x 0.8P	7 x M6 x 1P	11 x M6 x 1P	11 x M8 x 1.25P	11 x M10 x 1.5P	12 x M16 x 2P
D7	72	86	118	145	179	247	300
D8 <sub>H7</sub>	3	5	6	6	8	10	12
D10	8 x 3.4	8 x 4.5	8 x 5.5	8 x 5.5	12 x 6.6	12 x 9	16 x 13.5
D12	46.2	63.2	89.2	109.2	139.2	199.2	254.2
L1	4	8	12	12	12	16	20
L2	6.5	8	13.5	13.5	17	22.5	30.5
L3	3	3	6	6	6	8	12
L4	19.5	19.5	30	29	38	50	66
L5	7	7	10	10	14.6	15	20
L6	4	4	7	8	10	12	18
L8	107.5	126	172.5	201	263.5	334.5	392
L9	4	6	7	7	7	10	10
L10	0.5	0.5	1	1	1	1	1
C1 <sup>1</sup>	46	70	100	130	165	215	235
C2 <sup>1</sup>	M4 x 0.7P	M5 x 0.8P	M6 x 1P	M8 x 1.25P	M10 x 1.5P	M12 x 1.75P	M12 x 1.75P
C3 <sup>1</sup>	≤11 / ≤12	≤14 / ≤16	≤19 / ≤24	≤32	≤38	≤48	≤55
C4 <sup>1</sup>	30	34	40	50	60	85	116
C5 <sup>1</sup>	30	50	80	110	130	180	200
C6 <sup>1</sup>	3.5	8	4	5	6	6	6
C7 <sup>1</sup>	48	60	90	115	142	190	220
C8 <sup>1</sup>	19.5	19	17	19.5	22.5	29	63
C9 <sup>1</sup>	104.25	116.5	159.5	199	245.5	316	398.5
C10 <sup>1</sup>	13.25	13.5	10.75	13	15	20.75	53.5
C11 <sup>1</sup>	74	81.5	107.5	134	164.5	213.5	268.5

1. C1~C10 are motor specific dimensions (metric std shown). Refer to [www.apexdyna.com](http://www.apexdyna.com) and Design Tool to view your specific motor mounting system.

# Dimensions (2-stage, Ratio $i=25\sim 200$ ) / ADR Series

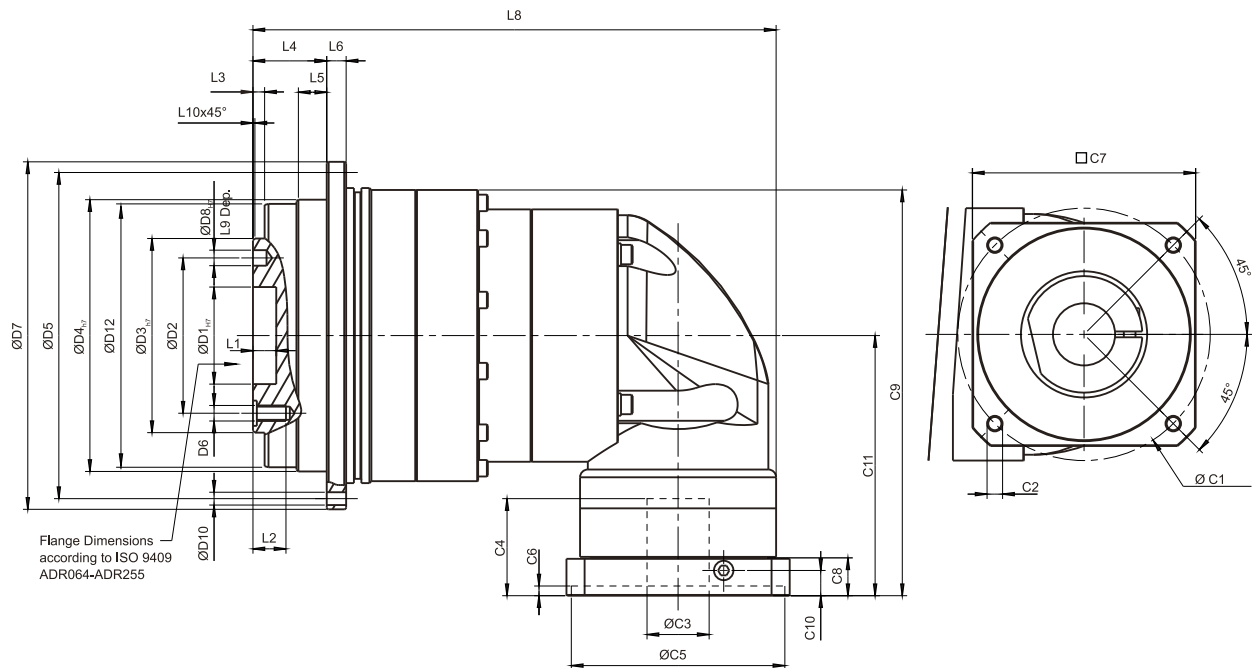

[unit: mm]

Dimension	ADR047	ADR064	ADR090	ADR110	ADR140	ADR200	ADR255
D1 <sub>H7</sub>	12	20	31.5	40	50	80	100
D2	20	31.5	50	63	80	125	140
D3 <sub>h7</sub>	28	40	63	80	100	160	180
D4 <sub>h7</sub>	47	64	90	110	140	200	255
D5	67	79	109	135	168	233	280
D6	4 x M3 x 0.5P	7 x M5 x 0.8P	7 x M6 x 1P	11 x M6 x 1P	11 x M8 x 1.25P	11 x M10 x 1.5P	12 x M16 x 2P
D7	72	86	118	145	179	247	300
D8 <sub>H7</sub>	3	5	6	6	8	10	12
D10	8 x 3.4	8 x 4.5	8 x 5.5	8 x 5.5	12 x 6.6	12 x 9	16 x 13.5
D12	46.2	63.2	89.2	109.2	139.2	199.2	254.2
L1	4	8	12	12	12	16	20
L2	6.5	8	13.5	13.5	17	22.5	30.5
L3	3	3	6	6	6	8	12
L4	19.5	19.5	30	29	38	50	66
L5	7	7	10	10	14.6	15	20
L6	4	4	7	8	10	12	18
L8	122	132.5	163	217.5	269.5	333.5	403
L9	4	6	7	7	7	10	10
L10	0.5	0.5	1	1	1	1	1
C1 <sup>2</sup>	46	46	70	100	130	165	215
C2 <sup>2</sup>	M4 x 0.7P	M4 x 0.7P	M5 x 0.8P	M6 x 1P	M8 x 1.25P	M10 x 1.5P	M12 x 1.75P
C3 <sup>2</sup>	≤11 / ≤12	≤11 / ≤12	≤14 / ≤15.875 / ≤16	≤19 / ≤24	≤32	≤38	≤48
C4 <sup>2</sup>	30	30	34	40	50	60	85
C5 <sup>2</sup>	30	30	50	80	110	130	180
C6 <sup>2</sup>	3.5	3.5	8	4	5	6	6
C7 <sup>2</sup>	48	48	60	90	115	142	190
C8 <sup>2</sup>	19.5	19.5	19	17	19.5	22.5	29
C9 <sup>2</sup>	103.25	108.25	128.25	166.5	209	269.5	340
C10 <sup>2</sup>	13.25	13.25	13.5	10.75	13	15	20.75
C11 <sup>2</sup>	74	74	81.5	107.5	134	164.5	213.5

2. C1-C10 are motor specific dimensions (metric std shown). Refer to [www.apexdyna.com](http://www.apexdyna.com) and Design Tool to view your specific motor mounting system.

# Specifications / ADS Series

## Gearbox Performance

Model No.	Stage	Ratio <sup>(1)</sup>	ADS047	ADS064	ADS090	ADS110	ADS140	ADS200	ADS255	
Nominal Output Torque $T_{2N}$	1	4	19	48	130	270	560	1,100	1,700	
		5	22	60	160	330	650	1,200	2,000	
		7	19	50	140	300	550	1,100	1,800	
		10	14	40	100	230	450	900	1,500	
	2	16	19	48	130	270	560	1,100	1,700	
		21	22	60	160	330	650	1,200	2,000	
		31	19	50	140	300	550	1,100	1,800	
		61	19	50	140	300	550	1,100	1,800	
		91	14	40	100	230	450	900	1,500	
		Emergency Stop Torque $T_{2NOT}^{(2)}$	Nm	1,2	4~91	3 times of Nominal Output Torque				
Nominal Input Speed $n_{1N}$	rpm	1,2	4~91	5,000	5,000	4,000	4,000	3,000	3,000	2,000
Max. Input Speed $n_{1B}$	rpm	1,2	4~91	10,000	10,000	8,000	7,500	4,500	4,500	3,800
Micro Backlash P0	arcmin	1	4~10	-	-	≤1	≤1	≤1	≤1	≤1
		2	16~91	-	-	-	≤3	≤3	≤3	≤3
Reduced Backlash P1	arcmin	1	4~10	≤3	≤3	≤3	≤3	≤3	≤3	≤3
		2	16~91	≤5	≤5	≤5	≤5	≤5	≤5	≤5
Standard Backlash P2	arcmin	1	4~10	≤5	≤5	≤5	≤5	≤5	≤5	≤5
		2	16~91	≤7	≤7	≤7	≤7	≤7	≤7	≤7
Torsional Rigidity	Nm/arcmin	1,2	4~91	3	7	14	25	50	145	225
Max. Tilting Moment $M_{2K}$	Nm	1,2	4~91	55	75	190	300	1,300	2,930	5,500
Max. Axial Load	N	1,2	4~91	990	1,050	2,850	2,990	10,590	16,660	29,430
Input Max. Radial Load $F_{1RB}^{(3)}$	N	1	4~10	165	395	1,300	1,525	2,800	4,500	12,500
		2	16~91	165	165	395	1,300	1,525	2,800	4,500
Input Max. Axial Load $F_{1aB}^{(3)}$	N	1	4~10	580	1,000	1,100	980	2,700	4,700	8,000
		2	16~91	580	580	1,000	1,100	980	2,700	4,700
Efficiency $\eta$	%	1	4~10	≥97%						
		2	16~91	≥94%						
Weight	kg	1	4~10	0.8	1.4	3.4	6.7	13.5	35.0	63.8
		2	16~91	1.1	1.6	4.0	7.3	16.6	36.4	74.7
Operating Temp	°C	1,2	4~91	-10°C~90°C						
Lubrication				Synthetic lubrication oils						
IP Level		1,2	4~91	IP65						
Mounting Position		1,2	4~91	all directions						
Noise <sup>(4)</sup>	dB(A)	1,2	4~91	≤56	≤58	≤60	≤63	≤65	≤67	≤70

## Gearbox Inertia

Model No.	Stage	Ratio <sup>(1)</sup>	ADS047	ADS064	ADS090	ADS110	ADS140	ADS200	ADS255
Moments of Inertia $J_1$	1	4	0.06	0.21	0.87	3.65	10.27	43.05	102.68
		5	0.06	0.21	0.83	3.53	10.17	41.76	99.12
		7	0.06	0.21	0.82	3.47	9.99	41.15	97.41
		10	0.06	0.21	0.81	3.45	9.93	40.97	97.03
	2	16	0.06	0.06	0.21	0.83	3.53	10.17	41.76
		21	0.06	0.06	0.21	0.83	3.53	10.17	41.76
		31	0.06	0.06	0.21	0.83	3.53	10.17	41.76
		61	0.06	0.06	0.21	0.81	3.45	9.93	40.97
		91	0.06	0.06	0.21	0.81	3.45	9.93	40.97

(1) Ratio ( $i=N_{in}/N_{out}$ )

(2) Max. acceleration torque  $T_{2B} = 60\%$  of  $T_{2NOT}$

(3) Applied to the output shaft center at 100 rpm

(4) The dB values are measured by gearbox with ratio 10 (1-stage) or ratio 100 (2-stage), no loading at 3,000 RPM or at the respective Nominal Input Speed by bigger model size.

By lower ratio and/or higher RPM, the noise level could be 3 to 5 dB higher.

# Dimensions (1-stage, Ratio $i=4\sim 10$ ) / ADS Series

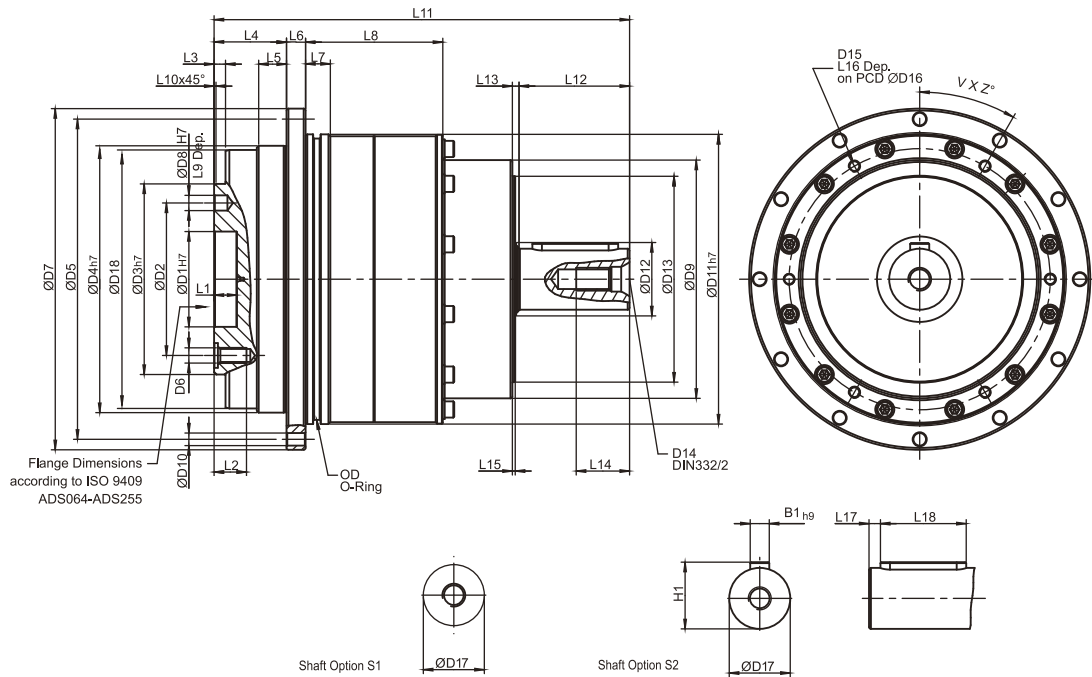

[unit: mm]

Dimension	ADS047	ADS064	ADS090	ADS110	ADS140	ADS200	ADS255
D1 <sub>H7</sub>	12	20	31.5	40	50	80	100
D2	20	31.5	50	63	80	125	140
D3 <sub>H7</sub>	28	40	63	80	100	160	180
D4 <sub>H7</sub>	47	64	90	110	140	200	255
D5	67	79	109	135	168	233	280
D6	4 x M3 x 0.5P	7 x M5 x 0.8P	7 x M6 x 1P	11 x M6 x 1P	11 x M8 x 1.25P	11 x M10 x 1.5P	12 x M16 x 2P
D7	72	86	118	145	179	247	300
D8 <sub>H7</sub>	3	5	6	6	8	10	12
D9	43	55	78	100	125	175	210
D10	8 x 3.4	8 x 4.5	8 x 5.5	8 x 5.5	12 x 6.6	12 x 9	16 x 13.5
D11 <sub>H7</sub>	60	70	95	120	152	212	255
D12	31	22	22	30	40	75	95
D13	37	50	62	82	108	145	172
D14	M4 x 0.7P	M4 x 0.7P	M5 x 0.8P	M8 x 1.25P	M12 x 1.75P	M16 x 2P	M20 x 2.5P
D15	M3 x 0.5P	M3 x 0.5P	M4 x 0.7P	M5 x 0.8P	M6 x 1P	M8 x 1.25P	M8 x 1.25P
D16	51.5	61.5	84	107	137	193	235
D17 <sub>K6</sub>	11	14	16	22	32	40	55
D18	46.2	63.2	89.2	109.2	139.2	199.2	254.2
L1	4	8	12	12	12	16	20
L2	6.5	8	13.5	13.5	17	22.5	30.5
L3	3	3	6	6	6	8	12
L4	19.5	19.5	30	29	38	50	66
L5	7	7	10	10	14.6	15	20
L6	4	4	7	8	10	12	18
L7	5	7.7	8	10	12	15	20
L8	32.5	43.5	47	62	72	89.5	112
L9	4	6	7	7	7	10	10
L10	0.5	0.5	1	1	1	1	1
L11	89.5	110.5	138.5	170	218	296	372.5
L12	18	22	28	36	58	82	115
L13	2.5	2.5	3.5	3.5	3.5	4.5	4.5
L14	10	10	12.5	19	28	36	42
L15	1.5	1.5	1.5	1.5	1.5	1.5	1.5
L16	5.5	5.5	7	9	11	14	14
L17	2	2	3	3	6	6	7
L18	14	18	22	28	45	70	90
B1 <sub>H9</sub>	4	5	5	6	10	12	16
H1	12.5	16	18	24.5	35	43	59
OD	56 x 2	66 x 2	90 x 3	110 x 3	145 x 3	200 x 5	238 x 5
V	4	4	4	4	6	6	6
Z	45	45	45	45	30	30	30

# Dimensions (2-stage, Ratio $i=16\sim 91$ ) / ADS Series

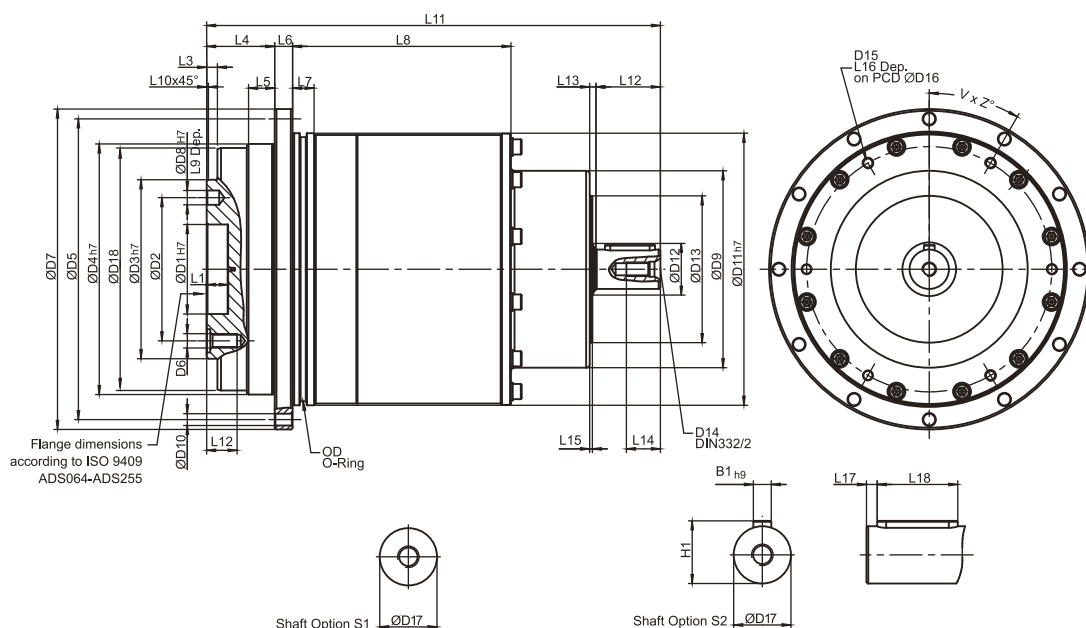

[unit: mm]

Dimension	ADS047	ADS064	ADS090	ADS110	ADS140	ADS200	ADS255
D1 <sub>H7</sub>	12	20	31.5	40	50	80	100
D2	20	31.5	50	63	80	125	140
D3 <sub>H7</sub>	28	40	63	80	100	160	180
D4 <sub>H7</sub>	47	64	90	110	140	200	255
D5	67	79	109	135	168	233	280
D6	4 x M3 x 0.5P	7 x M5 x 0.8P	7 x M6 x 1P	11 x M6 x 1P	11 x M8 x 1.25P	11 x M10 x 1.5P	12 x M16 x 2P
D7	72	86	118	145	179	247	300
D8 <sub>H7</sub>	3	5	6	6	8	10	12
D9	43	48	68	86	110	132	182
D10	8 x 3.4	8 x 4.5	8 x 5.5	8 x 5.5	12 x 6.6	12 x 9	16 x 13.5
D11 <sub>H7</sub>	60	70	95	120	152	212	255
D12	22	22	22	22	30	40	75
D13	37	37	50	62	82	108	145
D14	M4 x 0.7P	M4 x 0.7P	M4 x 0.7P	M5 x 0.8P	M8 x 1.25P	M12 x 1.75P	M16 x 2P
D15	M3 x 0.5P	M3 x 0.5P	M4 x 0.7P	M5 x 0.8P	M6 x 1P	M8 x 1.25P	M10 x 1.5P
D16	51.5	61.5	84	107	137	193	235
D17 <sub>K6</sub>	11	11	14	16	22	32	40
D18	46.2	63.2	89.2	109.2	139.2	199.2	254.2
L1	4	8	12	12	12	16	20
L2	6.5	8	13.5	13.5	17	22.5	30.5
L3	3	3	6	6	6	8	12
L4	19.5	19.5	30	29	38	50	66
L5	7	7	10	10	14.6	15	20
L6	4	4	7	8	10	12	18
L7	5	7.7	8	10	12	15	20
L8	62.5	63.5	67	82	122	79.5	177
L9	4	6	7	7	7	10	10
L10	0.5	0.5	1	1	1	1	1
L11	119.5	125.5	158.5	188	253.5	314.5	419.5
L12	18	18	22	28	36	58	82
L13	2.5	2.5	2.5	3.5	3.5	3.5	4.5
L14	10	10	10	12.5	19	28	36
L15	1.5	1.5	1.5	1.5	1.5	1.5	1.5
L16	5.5	5.5	7	9	11	14	18
L17	2	2	2	3	3	6	6
L18	14	14	18	22	28	45	70
B1 <sub>H9</sub>	4	4	5	5	6	10	12
H1	12.5	12.5	16	18	24.5	35	43
OD	56 x 2	66 x 2	90 x 3	110 x 3	145 x 3	200 x 5	238 x 5
V	4	4	4	4	6	6	6
Z	45	45	45	45	30	30	30

# Output Dimensions

**AD 047  
ADR 047  
ADS 047**

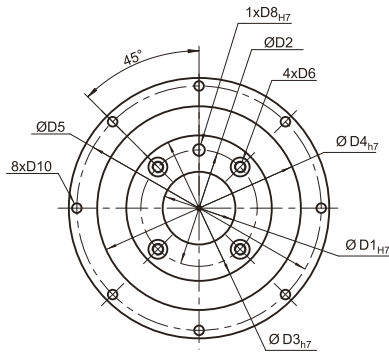

**AD 064 / AD 090  
ADR 064 / ADR 090  
ADS 064 / ADS 090**

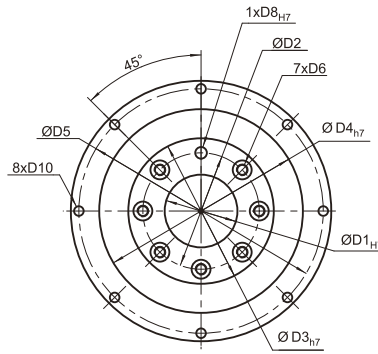

**AD 110  
ADR 110  
ADS 110**

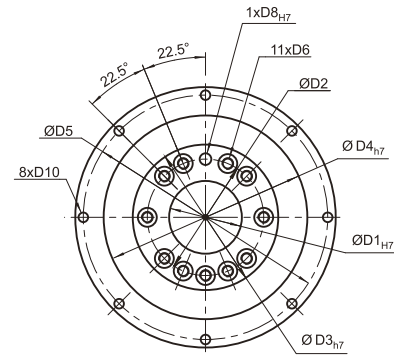

**AD 140 / AD 200  
ADR 140 / ADR 200  
ADS 140 / ADS 200**

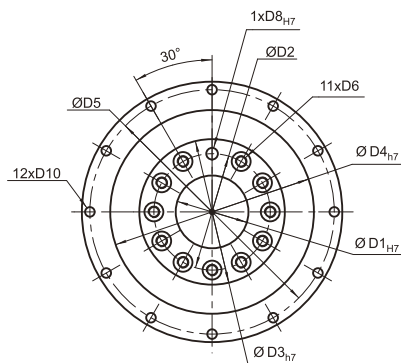

**AD 255  
ADR 255  
ADS 255**

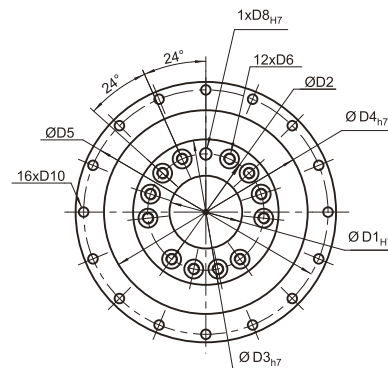

[unit: mm]

Dimension	AD047	AD064	AD090	AD110	AD140	AD200	AD255
	ADR047	ADR064	ADR090	ADR110	ADR140	ADR200	ADR255
	ADS047	ADS064	ADS090	ADS110	ADS140	ADS200	ADS255
D1 <sub>H7</sub>	12	20	31.5	40	50	80	100
D2	20	31.5	50	63	80	125	140
D3 <sub>H7</sub>	28	40	63	80	100	160	180
D4 <sub>H7</sub>	47	64	90	110	140	200	255
D5	67	79	109	135	168	233	280
D6	M3 x 0.5P	M5 x 0.8P	M6 x 1P	M6 x 1P	M8 x 1.25P	M10 x 1.5P	M16 x 2P
D8 <sub>H7</sub>	3	5	6	6	8	10	12
D10	3.4	4.5	5.5	5.5	6.6	9	13.5

# Max. Tilting Moment $M_{2K}$

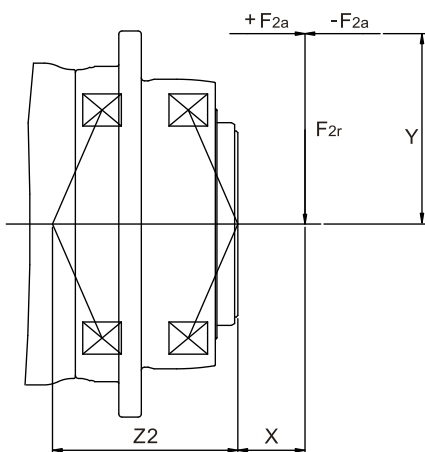

$$M_{2K} = \frac{F_{2a} * Y + F_{2r} * (X+Z2)}{1000}$$

$M_{2K}$  : [Nm]  
 $F_{2a}, F_{2r}$  : [N]  
 $X, Y, Z2$  : [mm]

AD / ADR / ADS	047	064	090	110	140	200	255
Z2 [mm]	37.9	46.2	63.1	75.5	92.2	119.2	148.8

Note : Applied to the output flange center at 100 rpm.

## ADS-Permitted Radial and Axial Loads

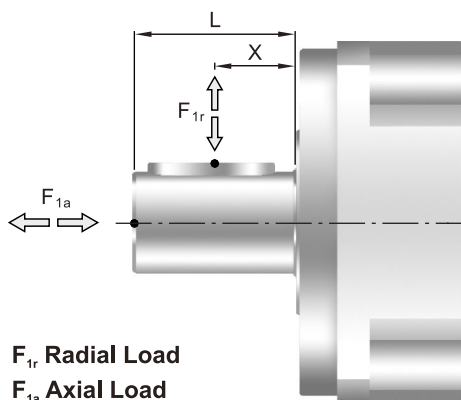

The permitted radial and axial loads on input shaft of the gearbox depend on the design of the gearbox supporting bearings. APEX use the extension straddle oversized ball bearing design. It can take heavy load from both axes.

$F_{1r}$  Radial Load  
 $F_{1a}$  Axial Load

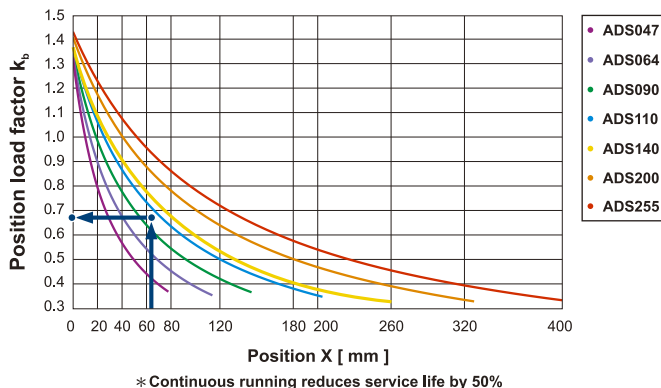
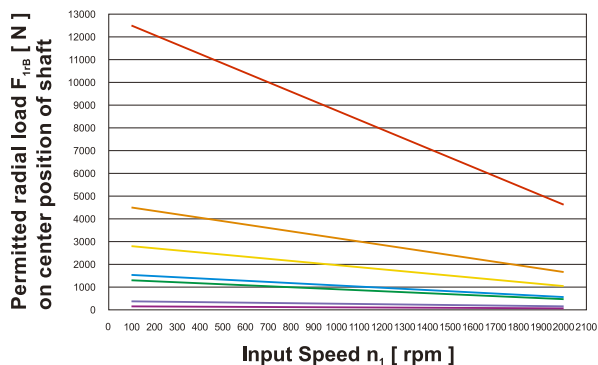

If radial force  $F_{1r}$  is exert on the center of the output shaft  $X=1/2 \times L$ . The permitted radial load is given on above diagram.

If radial force  $F_{1r}$  is not exert on the center of the output shaft  $X < 1/2 \times L$  or  $X > 1/2 \times L$ . The permitted radial and axial loads can be calculated by the position load factor  $K_b$  on the above diagram.



**APEX TAIWAN NORTH  
ANDTEK AUTOMATION CO.,LTD**  
TEL +886-02-82262655  
13F-5, No.2, Jian 8th Rd., Jhonghe Dist., New  
Taipei City 235, TAIWAN  
sales@andtek.com.tw  
www.apexdyna.com



**APEX TAIWAN CENTRAL  
ANDTEK AUTOMATION CO.,LTD**  
TEL +886-04-23594286  
9F-6, No.925, Sec.4, Taiwan Blvd., Xitun Dist.  
Taichung City 407 TAIWAN  
sales@andtek.com.tw  
www.apexdyna.com



**APEX TAIWAN SOUTH  
MEN JENN ELECTRIC CO., LTD.**  
TEL +886-06-2337332 ~ 6  
No.774, Zhonghua Rd., Yongkang Dist., Tainan  
City 710, TAIWAN  
menjenn@ms24.hinet.net  
www.apexdyna.com



**APEX DYNAMICS INC. SHANGHAI**  
TEL +86-21-69220577  
No.128 ZHUYING Road QINGPU Industry Area,  
Shanghai, CHINA  
sales@apexdyna.cn  
www.apexdyna.cn



**APEX DYNAMICS SHENZHEN, LTD.**  
TEL +86-755-84516325  
No. 1102A of D area , CFG mansion ,Bao Yuan  
Road , Bao'an District , Shenzhen ,CHINA.  
sales@szapexdyna.com  
www.szapexdyna.com



**APEX DYNAMICS BEIJING, LTD.**  
TEL +86-10-69570691  
NO.1,YaoPingRoad,SongZhuang Town, Tongzhou  
istrict, Beijing, CHINA.  
bjapexdyna@163.com  
www.bjapex.cn



**CHONGQING APEX DYNAMICS CO., LTD.**  
TEL +86-23-67686860  
406, Building 5, No.68, Jinyu Avenue, Beibu New  
Area, Chongqing, CHINA  
sales@cqapexdyna.com  
www.apexdyna.com



**APEX (XIAMEN) DYNAMICS TECHNOLOGY CO., LTD.**  
TEL +86-0592-720-5279  
Unit B-3, 1F., No.129, Jingquan Road, Jimei District,  
Xiamen, Fujian, CHINA  
sales@xmmapexdyna.com  
www.xmmapexdyna.com



**APEX DYNAMICS USA, INC.**  
TEL +1-631-2449040  
885 Marconi Avenue Ronkonkoma, NY 11779  
U.S.A.  
sales@apexdynamicsusa.com  
www.apexdynamicsusa.com



**APEX DYNAMICS KOREA**  
TEL +82-31-8179992  
1246-32, Seongsuk-dong, Ilsandong-gu, Goyang-city,  
Gyeonggi-do, KOREA (R.O.K) 410-570  
sales@apexdynakorea.co.kr  
www.apexdynakorea.co.kr



**APEX DYNAMICS JAPAN**  
TEL +86-092-4511202  
1-3-46, Hamnichibasi, Hakata-ku, Fukuoka,  
812-0897, JAPAN  
sales@apexdyna.jp  
www.apexdyna.jp



**APEX DYNAMICS SINGAPORE PTE LTD**  
TEL +65-62-626228  
3 South Buona Vista Road, #05-15 & #06-15.  
SINGAPORE 118136  
sales@apexdyna.com.sg  
www.apexdyna.com.sg



**APEX DYNAMICS (THAILAND) CO., LTD.**  
TEL +66-2-3266233  
73 Soi Ladkrabang 30, Kadkrabang Rd., Bangkok  
10520, THAILAND  
sales@apexdyna.co.th  
www.apexdyna.co.th



**APEX DYNAMICS BV**  
TEL +31-492-509995  
Churchillaan 101 5705 BK Helmond, NETHERLANDS  
sales@apexdyna.nl  
www.apexdyna.be



**APEX DYNAMICS  
POLSKA SP. Z O.O.**  
TEL +48-12-6304728  
Krakowska 50, 32-083 Balice, POLAND  
sales@apexdyna.pl  
www.apexdyna.pl



**APEX DYNAMICS SPAIN, S.L.**  
TEL +34-93-6562990  
Poligono Industrial Molí dels Frares, Calle C nº  
12,08620 - Sant Vicenç dels Horts, Barcelona, SPAIN  
apexdyna@apexdyna.es  
www.apexdyna.es



**LIMAN TRADING LIMITED FZC LLC**  
P.O. Box 97 , Postal Code 322, Corporate Parks,  
Sohar Free Zoon, Oman



**APEKS REDUKTOR VE DISLI SAN. TIC. LTD. STI.**  
TEL +90-232-4589960  
10042 Sok.No:10 AOSB Çiğli-Izmir, TURKEY  
sales@apexdyna.com.tr  
www.apexdyna.com.tr



**APEX DYNAMICS AUSTRALIA PTY LTD.**  
TEL +613-95-852739  
36 Taunton Drive, Cheltenham, Victoria 3192  
AUSTRALIA.  
sales@apexdyna.com.au  
www.apexdyna.com.au



**APEX DYNAMICS (I) JV**  
TEL +91-80-55345541  
GAT NO. 279, KHED SHIVAPUR BAUG, TALUKA  
HAVELI PUNE- 412205 INDIA.  
sales@apexdyna.co.in  
www.apexdyna.co.in



**APEX DYNAMICS FRANCE SAS**  
TEL +33-160-135097  
11 - Burospace F - 91570 -  
Bièvres, FRANCE  
info@apexdyna.fr  
www.apexdyna.fr



**APEX DYNAMICS SWEDEN AB**  
TEL +46-75-2424444  
Fredrikbergsgatan 2 SE-573 92 Tranås, SWEDEN  
sales@apexdyna.se  
www.apexdyna.se



**PT.APEX DYNAMICS INDONESIA**  
TEL +62 21 2928 3681  
Rukan Aralia Blok HY43 no.11, Harapan Indah II,  
Bekasi - Jawa Barat, INDONESIA 17214  
sales@apexdyna.co.id  
www.apexdyna.co.id



**APEX DYNAMICS GERMANY GMBH**  
TEL +49-7181-9329955  
Spanninger Str. 9, 73650 Winterbach, GERMANY  
Langer@apexdynamics.de  
www.apexdynamics.de



**APEX DYNAMICS CZECH S.R.O.**  
TEL +420-577-663877  
tř. Tomáše Bati 1851 765 02 Otrokovice ČESKÁ  
REPUBLIKA  
info@apexdynaczech.cz  
www.apexdynaczech.cz



**APEX DYNAMICS РОССИЯ**  
TEL +7-495-2255452  
+7-495-6462422  
г.Москва, ул. Южнопортовая, дом 7, строение  
"С", 3-й этаж  
info@apexdynarussia.ru  
www.apexdynarussia.ru



**APEX DYNAMICS UK**  
TEL +44-0121-737-1170  
Heath House, Cheadle Rd, Uttoxeter,  
ST14 7BY, UK  
mikeg@apexdynauk.com  
www.apexdynauk.com



**APEX DYNAMICS SWITZERLAND AG**  
TEL +41-55-4517020 Talstrasse 24, CH-8852  
Altendorf, SWITZERLAND  
info@apexdyna.ch  
www.apexdyna.ch



**APEX DYNAMICS MOTION SDN BHD**  
TEL +60 7237 1055  
No.1, Jalan Perniagaan Setia 3, Taman  
Perniagaan Setia, 81100 Johor Bahru, Johor,  
MALAYSIA (Setia Business Park 2 @ Iskandar  
Malaysia)  
sales@apexdyna.com.sg  
www.apexdyna.com.sg



**APEX DYNAMICS BRAZIL**  
TEL +55-47-30298700  
Rua Senador Petrônio Portela, 47 - Bloco 5, Zona  
Industrial Norte - CEP 89218-575 - Joinville (SC)  
luacan@neoyama.com.br  
adriano.duarte@neoyama.com.br  
www.neoyama.com.br



**APEX DYNAMICS ITALY**  
TEL +39 02.36634521  
VIA E. DE AMICIS, 2 – 20091 BRESSO (MI)  
info@apexdynamics.it  
www.apexdynamics.it



**Apex Dynamics Austria GmbH**  
TEL +43 07207884160  
Dr. Hans-Lechner-Strasse 6,  
5071 Wals-Siezenheim  
info@apexdynamics.at  
www.apexdynamics.at



**UAB "APEXO DINAMIKA"**  
TEL +370 52078165  
Medaus g. 28A,  
Medininku k., Vilniaus r. Sav.  
LT-13192  
info@apexdyna.lt



## APEX DYNAMICS, INC.

No.10, Keyuan 3rd RD.Situn District, Taichung City 40763, Taiwan (R.O.C)  
Tel:886-4-24650219 | Fax:886-4-24650118  
sales@apexdyna.com | http://www.apexdyna.com

APEX-2019-04-AD/ADR/ADS SERIES-4.0E-TWN

Printed in Taiwan

