

## ZETA Microstepping Drive Family



## Compumotor's ZETA Microstepping Drive Family

These microstepping drives are stand-alone, packaged microstepping drives that incorporate breakthrough techniques known as Active Damping™ (patented) and Electronic Viscosity™ (patent pending).

The ZETA family of drives come in 4 different power versions: ZETA4, ZETA4-240, ZETA8 and ZETA12.

Designed for reliability, the ZETA drive family offers premier quality and performance while being easy to use and apply. The ZETA drive family meets the need for global solutions:

- CE (LVD), CE(LVD and EMC) or low-noise applications
- UL Recognized
- 120VAC and 240VAC versions

The ZETA4, ZETA8, and ZETA12 operate at 120VAC and provide 4A, 8A, and 12A respectively.

The ZETA4-240, ZETA8, and ZETA12 comply with the Low Voltage [LVD (EN61010)] and Electromagnetic Compatibility [EMC (CISPR22/EN55022 Class B)] directives making it an excellent choice for machines built in or shipped to the European community. By designing the drive to meet the EMC Class B's rigid standards, the ZETA4-240, ZETA8, and ZETA12 also meets North America's FCC Class B emissions test making it the solution for low-noise applications. The ZETA4-240, ZETA8, and ZETA12 have also received UL approval.

The ZETA4-240 can be used for low- and high-power applications. For low-power applications, the ZETA 4-240 operates at 120VAC to provide the same performance as the ZETA4. For high-power applications, the ZETA4-240 runs off 240VAC to provide the same performance of an 8 AMP drive operating at 120 VAC.

### Features

#### Performance

- Standard step-and-direction input or CW/CCW input
- Torque from 43 oz-in (0.30 N-m) to 3480 oz-in (24.4 N-m)

#### Performance (continued)

- Active Damping™ benefits:
  - Damping ratios of up to 0.5
  - Higher acceleration than conventional step systems
  - Decrease motor vibration
  - Increase shaft power
  - Higher performance
- Electronic Viscosity™ benefits:
  - Reduce settling time
  - Increase slow speed smoothness (reduce velocity ripple)
  - Reduce audible noise

#### Protection Circuit

- Motor short circuits (phase-to-phase and phase-to-ground)
- Overtemperature
- Undervoltage
- Power dump (dissipates excess energy caused by load regeneration)

#### Physical

- A wide selection of motors is available for both 120 VAC and 240 VAC operation
- Drive status indicators: power, step input, over temperature and motor fault
- 120VAC (170VDC bus voltage) for ZETA4, ZETA4-240, ZETA8, and ZETA12
- 240VAC (340VDC bus voltage) for ZETA4-240
- Removable connectors for easy installation
- Selectable damping for optimized performance
- Optional EMC drive kit and EMC Cable kit consisting of AC mains filter and cabling to allow complete EMC or low noise system compliance for ZETA4-240, ZETA8, and ZETA 12.

Parker 核心代理商

北京润诚时代科技有限公司

自动化事业部

地址：北京市朝阳区汤立路218号C座968室

邮编：100012

电话：010-84450370

传真：010-84450371

网址：www.runcheng.net



**Specifications – ZETA4, ZETA8, ZETA12, and ZETA4-240**

	Parameter	Value
<b>Power</b>	AC Power Input	<b>ZETA4</b> ---- 95-132VAC Single Phase, 50/60Hz ---- <b>ZETA8</b> ---- 95-132VAC Single Phase, 50/60Hz ---- <b>ZETA12</b> ---- 95-132VAC Single Phase, 50/60Hz ---- <b>ZETA4-240</b> 95-264VAC Single Phase, 50/60Hz
	Motor Current (Apk)	<b>ZETA4</b> 0-4 Amps <b>ZETA8</b> 0-8 Amps <b>ZETA12</b> 0-12 Amps <b>ZETA4-240</b> 0-4 Amps
	Bus Voltage	----- 170 VDC nominal ----- <b>ZETA4-240</b> @120VAC: 170VDC nominal, @240VAC: 340VDC nominal
<b>Performance</b>	Accuracy	±5 arc min (0.0833°) typical. Unloaded-bidirectional with Compumotor supplied motors. Other motors may exhibit different absolute accuracy. ±1 arc min (0.0167°) Loaded-in addition to unloaded accuracy, per each frictional load equal to 1% rated torque.
	Repeatability	±5 arc sec (0.0014°) typical. Unloaded-one revolution returning to start point from same direction.
	Hysteresis	Less than 2 arc min (0.0334°) unloaded-bidirectional.
	Resolution	16 selectable choices: 200, 400, 1000, 2000, 5000, 10000, 12800, 18000, 20000, 21600, 25000, 25400, 25600, 36000, 50000, 50800
	Waveform	Selectable. Allows waveform shaping for optimum smoothness or relative accuracy. Pure sine; -4%, -6%, -10% 3rd harmonic.
<b>Motors</b>	Type	2-phase hybrid permanent magnet, 1.8 degree.
	Breakdown Voltage (HIPOT)	1,150VDC @ 120VAC input; 1,900VDC @ 240VAC input
	Number of Leads	4, 6 or 8
	Accuracy Grade	3%
<b>Amplifiers</b>	Inductance	0.5 mH minimum; 5 to 50 mH recommended range; 100 mH max
	Type	20 kHz fixed frequency, variable duty cycle PWM (pulse width modulated). Current controlled, bipolar type.MOSFETconstruction.
	Number of Phases	2
	Protection*	Phase-to-phase, phase-to-ground. If AC supply drops below 85VAC.
	• Short Circuit	Over-temperature shutdown fault at 113°F (50°C)
	• Brownout	If selected, motor current ramps to 50% of preset value if no step pulses are received for 1 second. Current levels are resumed upon receipt of next step pulse.
	• Over-temperature	This feature (used primarily for testing and verification of correct wiring) rotates the motor at approximately 1 rps in the negative (CCW) direction.
	Auto Standby	High-going pulse, 200 nsec min. width; max. pulse rate is 2 MHz. Logic High = positive (CW) rotation. Logic Low = negative (CCW) rotation. Direction input may change polarity, coincident with first step pulse.
	Automatic Test Function	Dip switch selectable. High-going pulse, 200 nsec min width; max pulse rate is 2 MHz.
	Step Input	Logic High = amplifier disable. Logic Low = normal operation.
Direction Input	Logic High = drive held in reset. Logic Low = normal operation.	
CW/CCW Input	Conducting = normal operation. Not Conducting = drive fault	
Shutdown Input		
Reset Input		
Fault Output		
<b>Environmental</b>	Operating drive	32°F to 113°F (0°C to 45°C) Fan cooling may be required if airflow restricted.
	Storage drive	-40°F to 185°F (-30°C to 85°C)
	Motor	212°F (100°C) maximum motor case temperature. Actual temperature rise is duty-cycle dependent.
Humidity	0-95%, non-condensing	
<b>Certifications</b>	UL Recognized	ZETA4, ZETA4-240, ZETA8, ZETA12
	CE (LVD)	ZETA4, ZETA4-240, ZETA8, ZETA12
	CE(LVD & EMC) (EMC for CISPR22/ EN55022 Class B)**	ZETA4-420, ZETA8, ZETA12 provided the following items are used and installed properly: • CE(LVD) motor. Compumotor recommends a terminal board (NPS) motor construction for easier installation • C10 (C10H) motor cable accessory (LVD/EMC cable kit) • ZETA EMC KIT
	Low Noise (FCC Class B)**	ZETA4-240, ZETA8, ZETA12 provided the following items are used and installed properly: • CE(LVD) motor. Compumotor recommends a terminal board (NPS) motor construction for easier installation • C10 (C10H) motor cable accessory (LVD/EMC cable kit) • ZETA EMC KIT
	* Drive shuts down in conditions listed	
	** System compliance	

**ZETA Series: True Innovation In Microstepping Technology. Call 1-800-358-9070 Today.**



**Features (continued)**

- Two fast (trigger) inputs for position capture, registration, etc.
- 16 programmable inputs (Opto-22 compatible)
- 8 programmable outputs (Opto-22 compatible)
- One auxiliary programmable output

**Language**

- 150,000 bytes of non-volatile memory for storing programs and paths
- Interrupts program execution on error conditions
- Encoder and motor position capture (using the trigger inputs)
- Registration (using the trigger inputs)
- Selectable damping (programmable) to optimize performance for changing loads
- Variable storage, conditional branching and math capability
- Program debug tools – single-step and trace modes, breakpoints, error messages and simulation of I/O

**Software Provided**

- Motion Architect™, Microsoft® Windows™-based application development software
- Dynamic Link Library (DLL) provided for use with Microsoft® Windows™ and Microsoft® Windows™ NT software development kits

**Optional Software**

- Dynamic Data Exchange (DDE) server available allowing data exchange between different Windows™ software applications

**Interface Capabilities**

- Direct interface to RP240 Remote Operator Panel
- Operates stand-alone or interfaces to PCs, PLCs, and thumbwheels
- One RS-232C communication port
- One RS232C/485 configurable port

**Physical**

- Stand-alone drive/controller package
- Status/fault LEDs to confirm proper operation (four diagnostic LEDs)
- Removable connectors for easy installation
- 120VAC (170VDC bus voltage) for ZETA6104, ZETA6104-240, ZETA6108, ZETA6112
- 240VAC (340VDC bus voltage) for ZETA6104-240

**Specifications – ZETA6104, ZETA6108, ZETA6112, and ZETA6104-240**

	Parameter	Value			
<b>Power</b>	AC Power Input	<b>ZETA6104</b>	<b>ZETA6108</b>	<b>ZETA6112</b>	<b>ZETA6104-240</b>
		----- 95-132VAC Single Phase, 50/60Hz -----			95-264VAC Single Phase, 50/60Hz
<b>Motor Current (Apk)</b>	Bus Voltage	0-4Amps	0-8 Amps	0-12 Amps	0-4 Amps
		----- 170 VDC nominal -----			@120VAC: 170VDC nominal, @240VAC: 340VDC nominal
<b>Performance</b>	Position range	±2,147,483,648 steps			
	Velocity range	1 to 2,000,000 steps/sec			
	Acceleration range	1 to 24,999,975 steps/sec <sup>2</sup>			
	Motion Algorithm Update Rate	2 ms			
<b>RS-232C Interface</b>	Connections	3-wire (Rx, Tx, and GND) connection to the COM1 and/or COM2 connectors.			
	Max number of daisy chained	Up to 99 units			
	Address settings	Selectable			
	Communication parameters	9,600 baud (auto-baud option); 8 data bits, 1 stop bit, no parity bit, full duplex.			
<b>RS-485 Interface</b>	Connections	2-wire or 4-wire (Rx+, Rx-, Tx+, Tx-) connection to the COM2 connector (COM2 needs to be configured to RS-485 Interface).			
	Max number of multi-dropped	Up to 99 units			
	Address settings	Selectable (see optional DIP switch setting and ADDR command).			
	Communication parameters	9,600 baud, 8 data bits, 1 stop bit, no parity bit, half duplex.			
<b>Protection</b>	Short Circuit	Phase-to-phase, phase-to-ground			
	Brownout	AC supply drops below 85VAC			
	Over-temperature	Over-temperature shutdown fault at 113°F (55°C)			
<i>Additional Specifications Continued on Following Page</i>					

**ZETA Series: True Innovation In Microstepping Technology. Call 1-800-358-9070 Today.**

**Specifications – ZETA6104, ZETA6108, ZETA6112, and ZETA6104-240 (Continued)**

**Inputs**

(see also I/O pinouts & circuit)

HOM, POS, NEG, TRG-A TRG-B, P-CUT	Powered by voltage applied to V_I/O terminal (switching levels: $\leq 1/3$ of V_I/O voltage = low, $\geq 2/3$ of V_I/O voltage = high). V_I/O can handle 5–24V with max current of 100 mA. Internal 6.8 K $\Omega$ pull-ups to AUX-P terminal—connect AUX-P to power source (+5V terminal or an external 5–24V supply) to source current or connect AUX-P to power source (+5V terminal or an external 5–24V supply) to sink current; AUX-P can handle 0–24V with max current of 50 mA. Voltage range for these inputs is 0–24V.
Encoder	Differential comparator accepts two-phase quadrature incremental encoders with differential (recommended) or single-ended outputs. Max voltage = 5VDC. Switching levels (TTL-compatible); Low $\leq 0.4V$ , High $\geq 2.4V$ . Maximum frequency = 1.6 MHz. Minimum time between transitions = 625 ns.
16 General Purpose Programmable	HCMOS compatible* with internal 6.8 K $\Omega$ pull-up to IN-P terminal—connect IN-P to power (+5V pin #49 or an external 5–24V supply) to source current or connect IN-P to GND to sink current; IN-P can handle 0–24V with max current of 100 mA. Voltage range = 0–24V.

**Outputs**

All outputs are optically isolated from the microprocessor (not from the other outputs).

9 Programmable (includes OUT-A)	Open collector output with 4.7 k $\Omega$ pull-ups. Can be pulled up by connecting OUT-P to power source (+5V terminal or an external 5–24V supply); OUT-P can handle 0–24V with max current of 50 mA. Outputs will sink up to 300 mA or source up to 5 mA at 5–24VDC. 8 general purpose outputs on the Programmable I/O connector, OUT-A on the I/O connector.
+5V Output	Internally supplied +5VDC. +5V terminals are available on the COM2, ENCODER and I/O connectors. Load limit (total load for all I/O connections) is 0.5A.

**Environmental**

Operating drive	32°F to 113°F (0°C to 45°C) Fan cooling may be required if airflow restricted.
Storage drive	-40°F to 185°F (-30°C to 85°C)
Motor	212°F (100°C) maximum motor case temperature. Actual temperature rise is duty-cycle dependent.
Humidity	0–95%, non-condensing

**Diagnostic LEDs**

Power/drive on, step pulses, drive over-temperature, and motor short circuit

**Certification**

UL Recognized	ZETA6104, ZETA6104-240, ZETA6108, ZETA6112
CE (LVD)	ZETA6104, ZETA6104-240, ZETA6108, ZETA6112

\* HCMOS-compatible switching voltage levels: low  $\leq 1.0V$ , high  $\geq 3.25V$ ; TTL-compatible switching voltage levels: low  $\leq 0.4V$ ; high  $\geq 2.4V$

# Speed-Torque Curves (@120VAC)

## ZETA with VS Motors

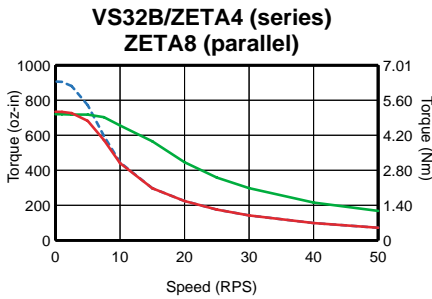
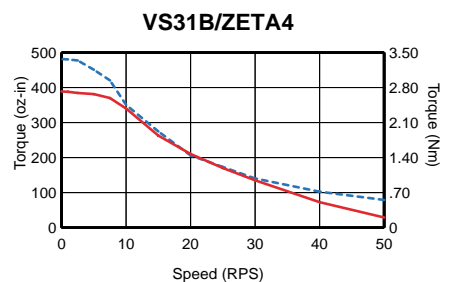
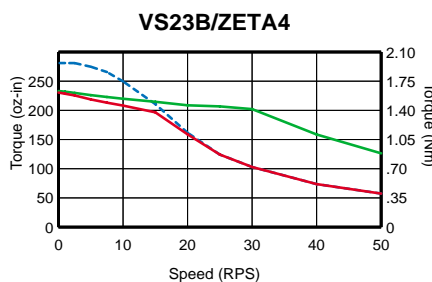
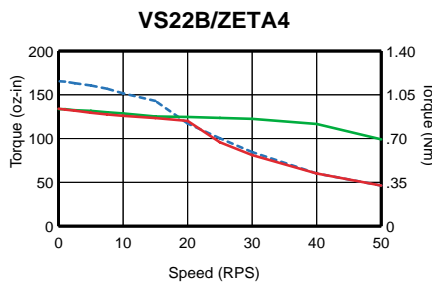
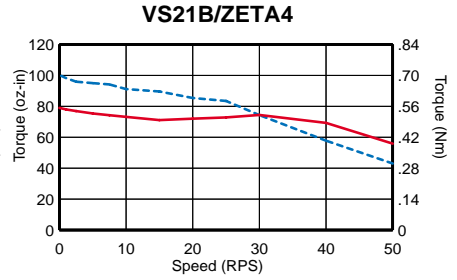
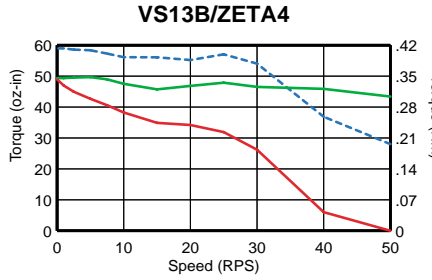
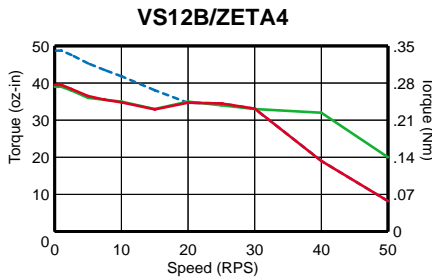

— SERIES — PARALLEL - - - FULL

*For ZETA Series Motor Specifications and dimensions, please refer to the E Series Motor Specifications located in the Gemini Section.*

## ZETA with OS Motors

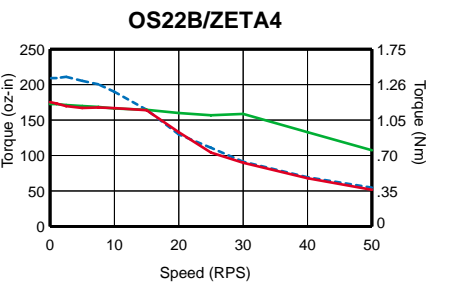
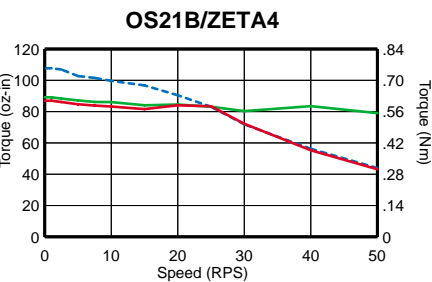
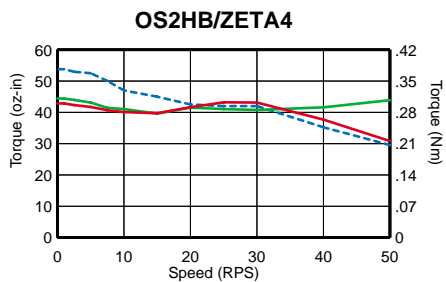

— SERIES — PARALLEL - - - FULL

ZETA Series: True Innovation In Microstepping Technology. Call 1-800-358-9070 Today.

# Speed-Torque Curves (@120VAC) (cont'd)

## ZETA with ES Motors

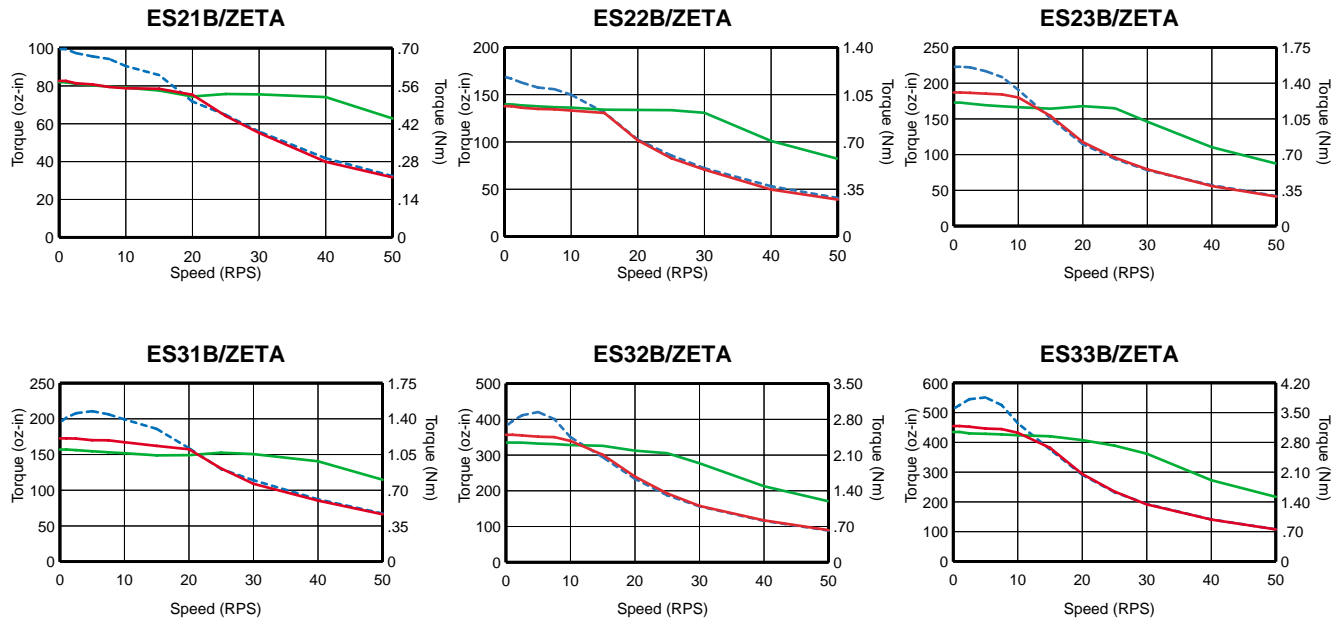

## ZETA with RS Motors

— SERIES — PARALLEL - - - FULL

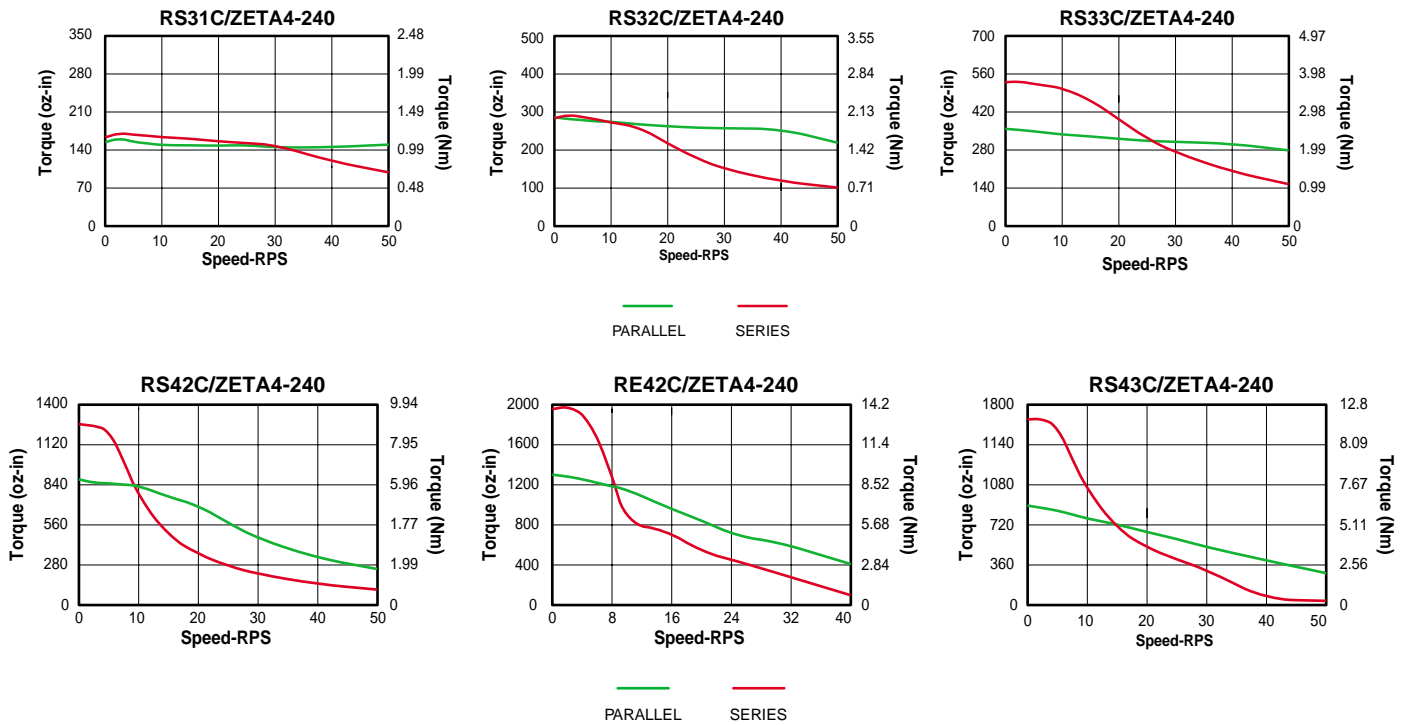

Parallel connected motors are limited to 50% duty cycle when operated above 5 rps. For greater than 50% duty cycle above 5 rps, connection must be made to the motor in series. Fan cooling the motor will increase duty cycles above 5 rps.

Viscous damper is not required to achieve speed-torque curves.

Note: ±10% torque variance due to motor tolerance



# Speed-Torque Curves (@120VAC) (cont'd)

## ZETA with TS Motors

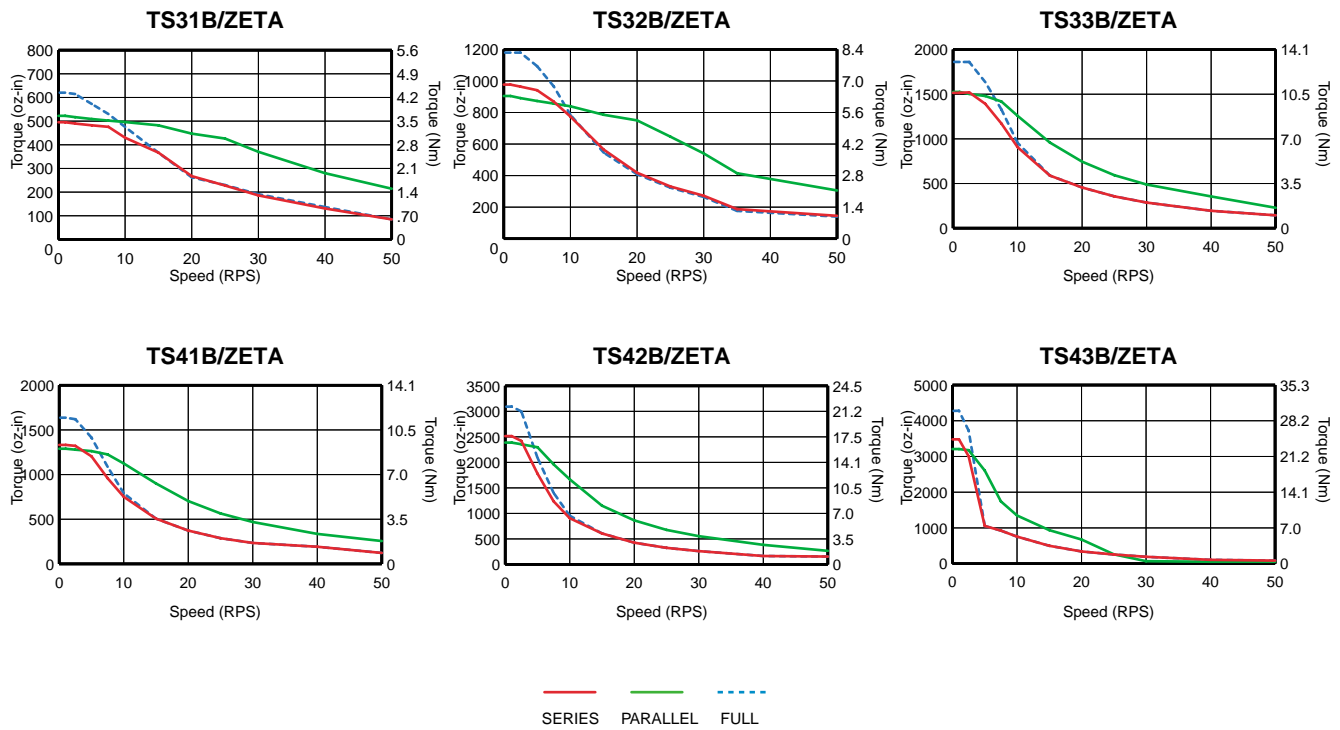

ZETA Series: True Innovation In Microstepping Technology. Call 1-800-358-9070 Today.





**ES Series Stepper  
Motor Specifications  
Size 23 & 34 Frame Sizes**

Parameters		Size 23 Frame			Size 34 Frame		
		ES21B	ES22B	ES23B	ES31B	ES32B	ES33B
Static torque	oz-in	65	100	125	160	300	400
	(N-m)	(0.46)	(0.71)	(0.89)	(1.14)	(2.14)	(2.80)
Rotor inertia	oz-in <sup>2</sup>	0.546	1.1	1.69	3.47	6.76	10.47
	(kg-m <sup>2</sup> x 10 <sup>-6</sup> )	(9.998)	(20.1)	(30.9)	(63.4)	(124)	(191)
Drive Current Apk (Arms)	Series	1.76 (1.24)	2.01 (1.42)	2.63 (1.86)	2.76 (1.95)	3.63 (2.57)	4.0 (2.83)
	Parallel	3.5 (2.47)	4.0 (2.83)	5.16 (3.65)	5.42 (3.83)	7.23 (5.11)	8.0 (5.66)
Phase Inductance	Series	17.37	18.5	17	10	10.5	9.2
	Parallel	4.34	4.62	4.25	2.5	2.62	2.3
<b>Bearings</b>							
Thrust load	lb	25	25	25	50	50	50
	(kg)	(11.3)	(11.3)	(11.3)	(22.6)	(22.6)	(22.6)
Radial load	lb	15	15	15	25	25	25
	(kg)	(6.8)	(6.8)	(6.8)	(11.3)	(11.3)	(11.3)
End play	in	0.005	0.005	0.005	0.005	0.005	0.005
Reversing load Equal to 1 lb	(cm)	(0.013)	(0.013)	(0.013)	(0.013)	(0.013)	(0.013)
Radial play Per 0.5 lb load	in	0.0008	0.0008	0.0008	0.0008	0.0008	0.0008
	(cm)	(0.002)	(0.002)	(0.002)	(0.002)	(0.002)	(0.002)
<b>Weight (net)</b>							
Motor+Cable +Connector	lb	1.6	2.4	3.2	3.8	5.1	8.3
	(kg)	(0.7)	(1.1)	(1.5)	(1.7)	(2.3)	(3.8)
<b>Motor Cable</b>							
Wire size	AWG	24	24	24	22	22	22
	(mm <sup>2</sup> )	(0.25)	(0.25)	(0.25)	(0.34)	(0.34)	(0.34)

All motors: Cable length = 10 feet (3 m); attached connector is prewired for series current.

**OS & VS Series Stepper  
Motor Specifications  
Size 17, 23 & 34 Frame Sizes**

Parameters		Size 23 Frame			Size 17 Frame		Size 23 Frame			Size 34 Frame	
		OS2HB	OS21B	OS22B	VS12B	VS13B	VS21B	VS22B	VS23B	VS31B	VS32B
Static torque	oz-in	61	127	238	57	73	116	195	335	552	1270
	(Nm)	(0.4)	(0.9)	(1.7)	(0.4)	(0.5)	(0.8)	(1.4)	(2.4)	(3.9)	(9.0)
Rotor inertia	oz-in <sup>2</sup>	0.39	0.66	1.39	0.3	0.37	0.66	1.64	2.62	7.65	14.8
	(kg-cm <sup>2</sup> )	(0.07)	(0.12)	(0.25)	(0.054)	(0.068)	(0.12)	(0.3)	(0.48)	(1.4)	(2.7)
Drive Current Apk (Arms)	Series	1.8 (1.3)	1.9 (1.3)	2.4 (1.7)	1.0 (0.7)	1.0 (0.7)	2.3 (1.6)	2.0 (1.4)	2.0 (1.4)	3.0 (2.1)	3.1 (2.2)
	Parallel	3.6 (2.6)	3.8 (2.6)	4.8 (3.4)	2.0 (1.4)	2.0 (1.4)	4.6 (3.2)	4.0 (2.8)	4.0 (2.8)	6.0 (4.2)	6.2 (4.4)
Phase Inductance (mH)	Series	8.6	12	16.6	3.2	2.8	5	12.0	15.4	15.8	25.0
	Parallel	2.2	3	4.2	(0.85)	(0.7)	(1.25)	(3.0)	(3.85)	(3.95)	(6.25)
Drive Bus Voltage	(VDC)	170	170	170	170	170	170	170	170	170	170
Detent Torque	oz-in	2.5	4.0	7.0	2.7	3.0	2.7	3.3	6.0	14.0	28.0
	(N-m)	(0.02)	(0.03)	(0.05)	(0.02)	(0.02)	(0.02)	(0.02)	(0.04)	(0.1)	(0.2)
Bearings Information Thrust Load	lb	13	13	13	11	11	17.6	17.6	17.6	35.3	35.3
	(kg)	(5.9)	(5.9)	(5.9)	(5)	(5)	(8)	(8)	(8)	(16)	(16)
Radial Load	lb	20	20	20	7.7	7.7	15.0	15.0	15.0	30.9	30.9
	(kg)	(9.1)	(9.1)	(9.1)	(3.5)	(3.5)	(6.8)	(6.8)	(6.8)	(14)	(14)
End Play	in	0.001	0.001	0.001	0.003	0.003	0.003	0.003	0.003	0.0032	0.0032
	(mm)	(0.025)	(0.025)	(0.025)	(0.075)	(0.075)	(0.075)	(0.075)	(0.075)	(0.080)	(0.080)
Radial Play (Per 0.5 lb load)	in	0.0008	0.0008	0.0008	0.001	0.001	0.001	0.001	0.001	0.0008	0.0008
	(mm)	(0.02)	(0.02)	(0.02)	(0.025)	(0.025)	(0.025)	(0.025)	(0.025)	(0.020)	(0.020)
Motor Weight	lb	1	1.5	2.5	0.55	0.77	1.03	1.54	2.2	3.86	6.18
	(kg)	(0.5)	(0.7)	(1.1)	(0.25)	(0.35)	(0.47)	(0.7)	(1.0)	(1.75)	(2.8)
Certifications	UL recognized	Pending	Pending	Pending	No	No	No	No	No	No	No
	CE (LVD)	Yes	Yes	Yes	No	No	No	No	No	No	No
	CE (EMC & LVD)*	No	No	No	No	No	No	No	No	No	No

ZETA Series: True Innovation In Microstepping Technology. Call 1-800-358-9070 Today.

Motor Specifications - 170 VDC Motor

Size 23 Frame

Parameters		OS2HB	OS21B	OS22B
Static torque**	oz-in	43	82	155
	(Nm)	(0.30)	(0.58)	(1.09)
Rotor inertia	oz-in <sup>2</sup>	0.39	0.66	1.39
	(kg-cm <sup>2</sup> )	(0.07)	(0.12)	(0.25)
Drive Current (Apk)(Arms)**	Series	1.5 (1.0)	1.8 (1.3)	2.2 (1.5)
	Parallel	3.0 (2.1)	4.0 (2.8)	4.0 (2.8)
Phase Inductance (mH)***	Series	8.6	12	16.6
	Parallel	2.2	3	4.2
Drive Bus Voltage	(VDC)	170	170	170
Detent Torque	oz-in	2.5	4.0	7.0
	(N-m)	(0.02)	(0.03)	(0.05)
<b>Bearings Information</b>				
Thrust Load	lb	13	13	13
	(kg)	(5.9)	(5.9)	(5.9)
Radial Load	lb	20	20	20
	(kg)	(9.1)	(9.1)	(9.1)
End Play (Reversing load equal to 1 lb)	in	0.001	0.001	0.001
	(mm)	(0.025)	(0.025)	(0.025)
Radial Play (Per 0.5 lb load)	in	0.0008	0.0008	0.0008
	(mm)	(0.02)	(0.02)	(0.02)
Motor Weight	lb	1	1.5	2.5
	(kg)	(0.5)	(0.7)	(1.1)
Certifications	UL recognized	Pending	Pending	Pending
	CE (LVD)	Yes	Yes	Yes
	CE (EMC & LVD)*	No	No	No

For ZETA Series Motor Specifications and dimensions, please refer to the E Series Motor Specifications located in the Gemini Section.

Motor Specifications - 170 VDC Motor

Size 34 Frame

Size 42 Frame

Parameters		TS31B	TS32B	TS33B	TS41B	TS42B	TS43B
Static torque**	oz-in	455	647	1525	1332	2515	3479
	(N-m)	(3.19)	(4.53)	(10.68)	(9.32)	(17.61)	(24.35)
Rotor inertia	oz-in <sup>2</sup>	7.80	14.67	21.89	30.22	59.68	88.51
	(kg-cm <sup>2</sup> )	(1.43)	(2.68)	(4.01)	(5.53)	(10.92)	(16.20)
Drive Current (Apk)(Arms)**	Series	3.3 (2.3)	3.1 (2.2)	5.6 (4.0)	6.4 (4.5)	6.7 (4.7)	6.9 (4.9)
	Parallel	6.7 (4.7)	6.2 (4.4)	12.0 (8.5)	12.0 (8.5)	12.0 (8.5)	12.0 (8.5)
Drive Bus Voltage	(VDC)	170	170	170	170	170	170
Phase Inductance (mH)***	Series	10.3	10.3	13.6	15.8	22.0	30.7
	Parallel	2.6	2.6	3.4	3.9	5.5	7.7
Detent Torque	oz-in	18	36	54	42	84	106
	(Nm)	(0.13)	(0.25)	(0.38)	(0.30)	(0.59)	(0.75)

Motor Specifications - 170 VDC Motor (cont'd)

Parameters	Size 34 Frame			Size 42 Frame			
	TS31B	TS32B	TS33B	TS41B	TS42B	TS43B	
<b>Bearings Information</b>							
Thrust Load	lb (kg)	305 (139)	305 (139)	305 (139)	404 (184)	404 (184)	404 (184)
Radial Load	lb (kg)	65 (30)	65 (30)	110 (50)	125 (57)	110 (50)	110 (50)
End Play (Reversing load equal to 1 lb)	in (mm)	0.001 (0.025)	0.001 (0.025)	0.001 (0.025)	0.001 (0.025)	0.001 (0.025)	0.001 (0.025)
Radial Play (Per 0.5 lb load)	in (mm)	0.0008 (0.020)	0.0008 (0.020)	0.0008 (0.020)	0.0008 (0.020)	0.0008 (0.020)	0.0008 (0.020)
Motor Weight	lb (kg)	5.0 (2.3)	8.4 (3.8)	11.9 (5.4)	11.0 (5.0)	18.4 (8.4)	25.7 (11.7)
Certifications	UL recognized CE (LVD) CE (EMC & LVD)*	Yes Yes *	Yes Yes *	Yes Yes *	Yes Yes *	Yes Yes *	Yes Yes *

For ZETA Series Motor Specifications and dimensions, please refer to the E Series Motor Specifications located in the Gemini Section.

Motor Specifications - 340VDC Motor

Parameters	Size 34 Frame			Size 42 Frame			
	RS31C	RS32C	RS33C	RS42C	RE42C	RS43C	
Static torque**	oz-in (N-m)	171 (1.21)	292 (2.06)	532 (3.76)	1,266 (8.94)	1,959 (13.8)	1,671 (11.8)
Rotor inertia	oz-in <sup>2</sup> (kg-cm <sup>2</sup> )	3.20 (0.59)	6.56 (1.20)	9.65 (1.77)	61.76 (11.30)	61.76 (11.30)	92.64 (16.95)
Drive Current (Apk)(Arms)**	Series Parallel	2.2 (1.6) 4.0 (2.8)	2.8 (2.0) 4.0 (2.8)	3.5 (2.5) 4.0 (2.8)	3.2 (2.3) 4.0 (2.8)	3.4 (2.4) 4.0 (2.8)	4.0 (2.8) 4.0 (2.8)
Phase Inductance (mH)***	Series Parallel	17.4 4.4	26.2 6.6	23.3 5.8	65.4 16.4	55.6 13.9	42.9 10.7
Drive Bus Voltage	(VDC)	340	340	340	340	340	340
Detent Torque	oz-in (N-m)	8.8 0.062	18.0 0.130	27.0 0.190	50.0 (0.350)	81.0 (0.570)	71.0 (0.500)
<b>Bearings Information</b>							
Thrust Load	lb (kg)	180 (81.6)	180 (81.6)	180 (81.6)	400 (182)	400 (182)	400 (182)
Radial Load	lb (kg)	35 (15.9)	35 (15.9)	35 (15.9)	140 (63.6)	140 (63.6)	140 (63.6)
End Play (Reversing load equal to 1 lb)	in (mm)	0.001 (0.025)	0.001 (0.025)	0.001 (0.025)	0.001 (0.025)	0.001 (0.025)	0.001 (0.025)
Radial Play (Per 0.5 lb load)	in (mm)	0.0008 (0.02)	0.0008 (0.02)	0.0008 (0.02)	0.0008 (0.02)	0.0008 (0.02)	0.0008 (0.02)
Motor Weight	lb (kg)	3.2 (1.5)	5.3 (2.4)	7.6 (3.5)	18.2 (8.3)	18.2 (8.3)	25.7 (11.7)
Certifications	UL recognized CE (LVD) CE (EMC & LVD)*	Yes Yes *	Yes Yes *	Yes Yes *	Yes Yes *	Yes Yes *	Yes Yes *

\* EMC is a system compliance. To comply with EMC and low-noise (C15PR22/EN55022 Class B or FCC Class B emissions) standards, the following items are required:

- ZETA4-240, ZETA8, or ZETA12 Drive
- ZETA EMC KIT
- C10 motor accessory (LVD/EMC cable kit)
- CE(LVD) motor for LVD. Compumotor recommends a terminal board (NPS) motor construction for easier EMC installation

\*\* Values shown in speed-torque curves

\*\*\* Small signal values

ZETA Series: True Innovation In Microstepping Technology. Call 1-800-358-9070 Today.

# ZETA Series CE Motor Dimensional Drawings

## Size 23 Frame, O Series

Dimensions in inches (mm)

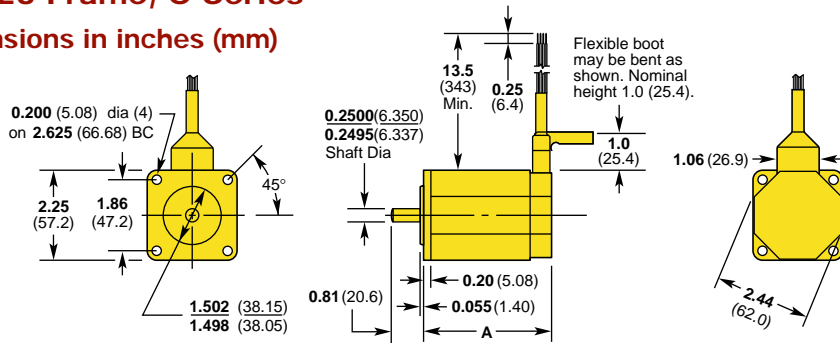

Model	A	
OS2HA (OEM57-40)	1.60 (40.6)	
OS21A (OEM57-51)	2.06 (52.3)	
OS22A (OEM57-83)	3.10 (87.7)	

## Size 34 Frame, R Series

Dimensions in inches (mm)

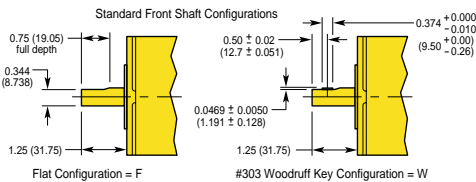
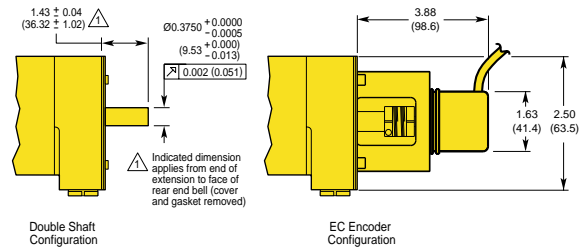
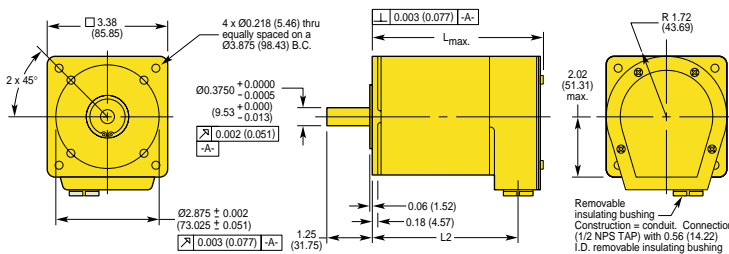

Model	L <sub>max</sub>	L <sub>2</sub>
RS31□-□□□NPS	3.62 (91.95)	2.87 (72.9)
RS32□-□□□NPS	4.77 (121.16)	4.02 (102.11)
RS33□-□□□NPS	6.05 (153.67)	5.30 (134.62)

## Size 42 Frame, R Series

Dimensions in inches (mm)

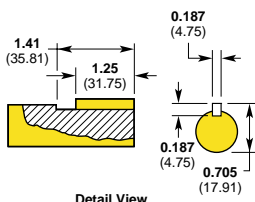
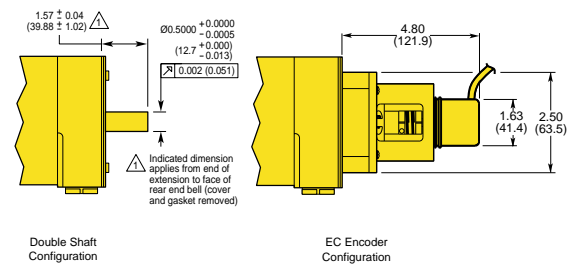
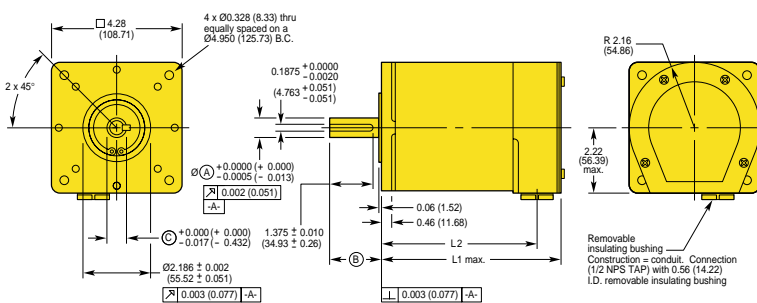

Model	L <sub>max</sub>	L <sub>2</sub>	A	B	C
RS42□-□□□NPS	8.04 (204.22)	7.29 (185.17)	0.625 (15.87)	2.19 (55.63)	0.705 (17.91)
RE42□-□□□NPS	8.04 (204.22)	7.29 (185.17)	0.625 (15.87)	2.19 (55.63)	0.705 (17.91)
RS43C-□□□NPS	10.56 (268.23)	9.81 (249.18)	0.75 (19.05)	2.19 (55.63)	0.83 (21.09)

# ZETA Series CE Motor Dimensional Drawings

## Size 34 Frame, T Series

Dimensions in inches (mm)

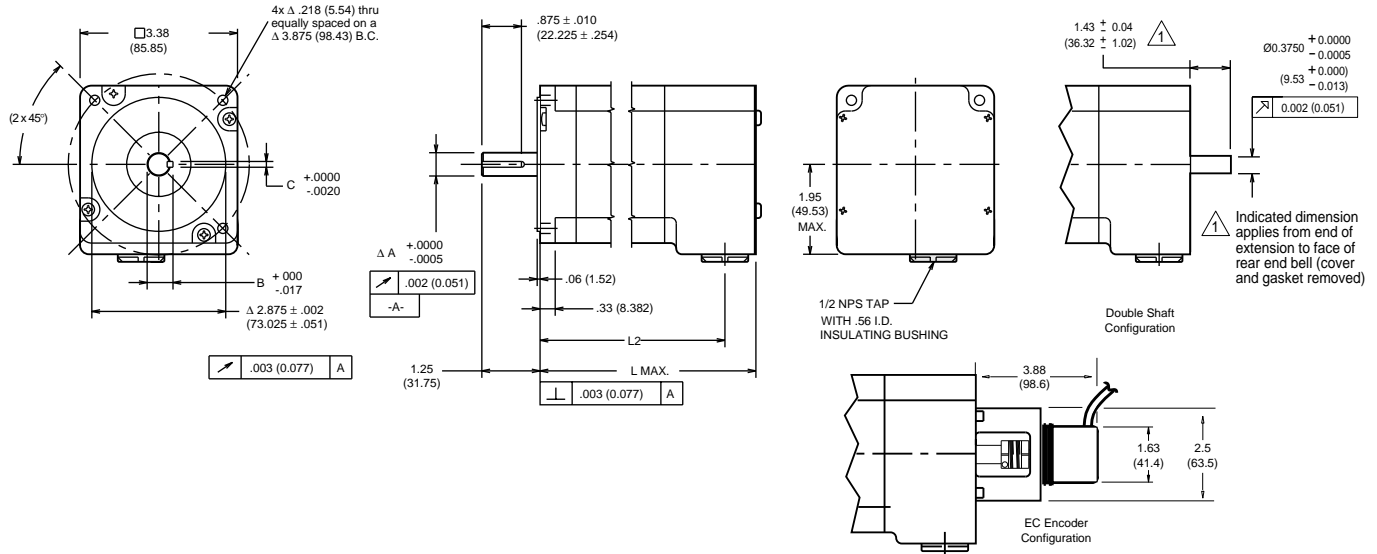

Model	Lmax	L2	A	B	C
TS31B-□K□NPS	4.44 (112.78)	3.70 (93.98)	0.5000 (12.70)	.555 (14.097)	.1250 (3.175)
TS32B-□K□NPS	5.96 (151.38)	5.22 (132.59)	0.5000 (12.70)	.555 (14.097)	.1250 (3.175)
TS33B-□K□NPS	7.48 (189.99)	6.74 (171.20)	0.6250 (15.88)	.705 (17.907)	.1875 (4.763)

## Size 42 Frame, T Series

Dimensions in inches (mm)

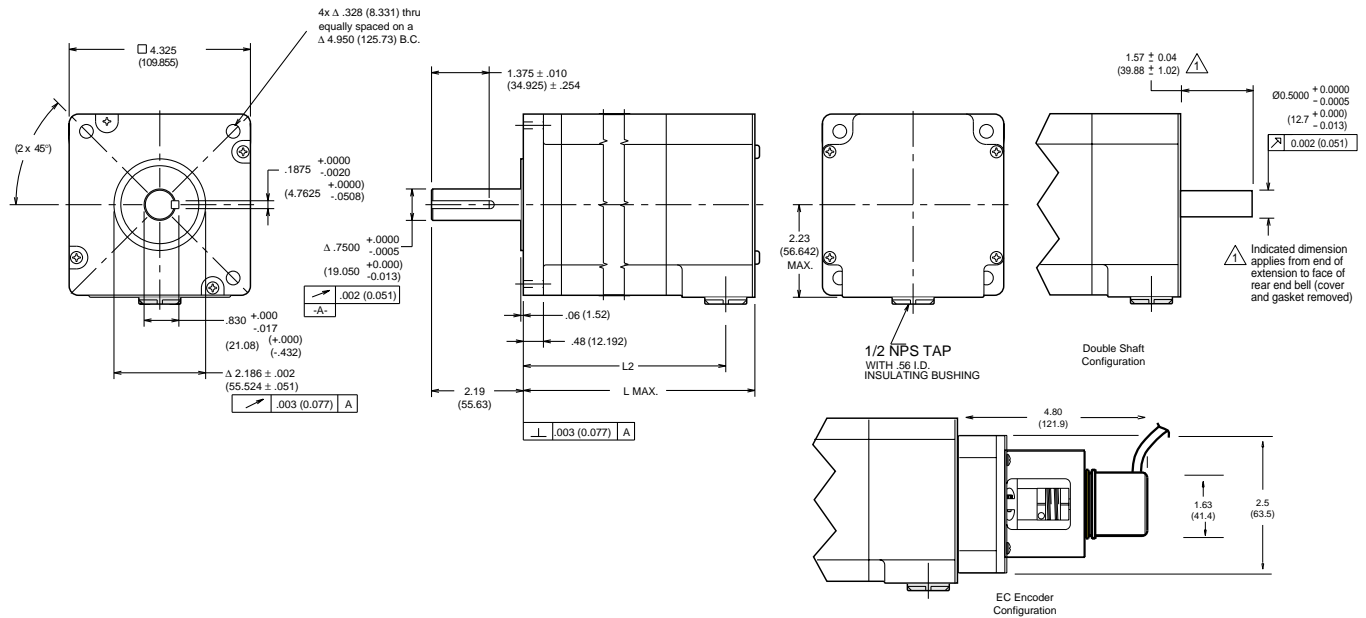

Model	Lmax	L2
TS41B-□K□NPS	5.20 (132.08)	4.46 (113.28)
TS42B-□K□NPS	7.22 (183.39)	6.48 (164.59)
TS43B-□K□NPS	9.23 (234.44)	8.49 (215.65)

ZETA Series: True Innovation In Microstepping Technology. Call 1-800-358-9070 Today.

# ZETA Dimensional Drawings

## ZETA4 Dimensions

Dimensions in inches (mm)

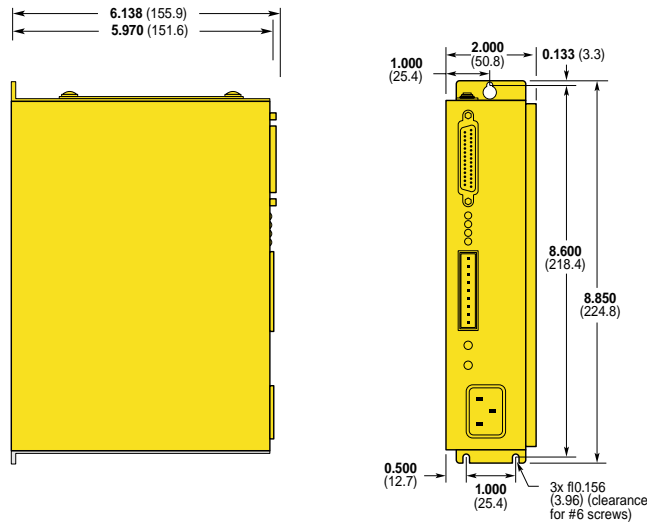

## ZETA4-240, ZETA8, ZETA12 Dimensions

Dimensions in inches (mm)

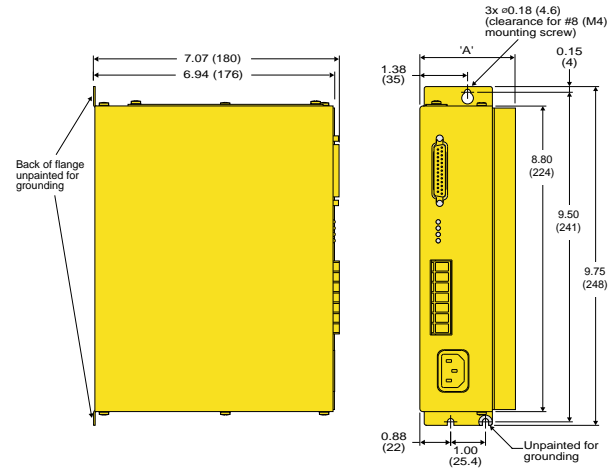

Product	'A'
ZETA8 & ZETA4-240	2.75 (70)
ZETA12	3.75 (96)

## ZETA6104 Dimensions

Dimensions in inches (mm)

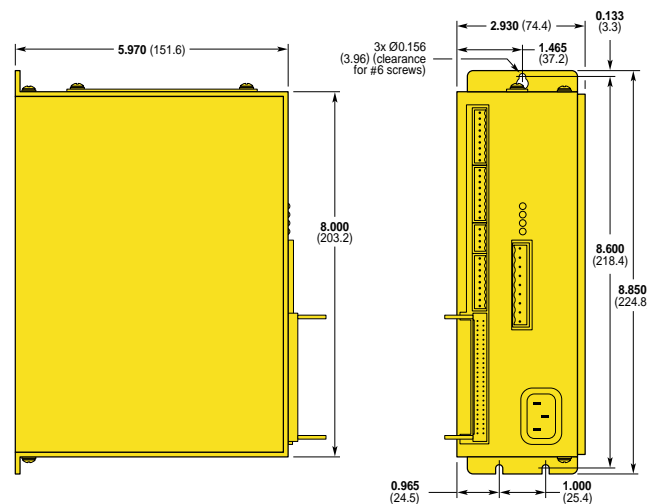

## ZETA6104-240, ZETA6108, ZETA6112

Dimensions in inches (mm)

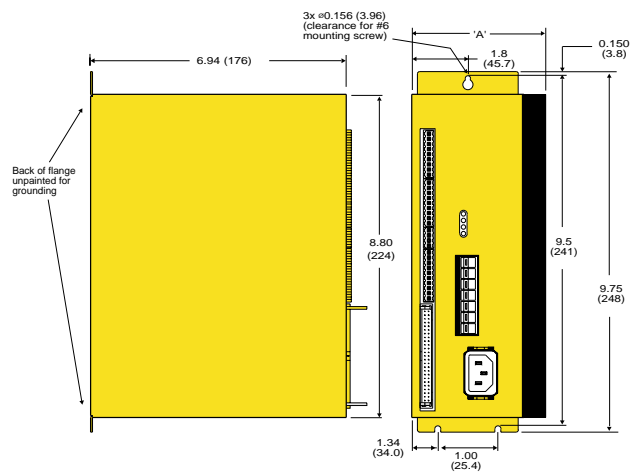

Product	'A'
ZETA6104-240	3.69 (93.7)
ZETA6108	3.69 (93.7)
ZETA6112	4.69 (119.2)



# ZETA6000 Series Connection Pin-Out List

(ZETA6104, ZETA6104-240, ZETA6108 & ZETA6112)

COM1 4-Pin Screw Terminal	
Pin No	Signal
1	Rx
2	Tx
3	Ground
4	Shield

COM2 5-Pin Screw Terminal	
Pin No	Signal
1	+5VDC (out)/Rx+
2	Ground/RX-
3	Rx/Tx+
4	Tx/Tx-
5	Shield/Ground

Encoder 9-Pin Screw Terminal	
Pin No	Signal
1	Shield
2	Ground
3	Z-
4	Z+
5	B-
6	B+
7	A-
8	A+
9	+5VDC (out)

I/O 10-Pin Screw Terminal	
Pin No	Signal
1	Trigger A
2	Trigger B
3	Output A-
4	Ground
5	Pulse cut-off
6	+5VDC (out)
7	Output pull-up
8	Input pull-up
9	Auxiliary pull-up
10	Voltage Reference (V <sub>I/O</sub> )

Motor 9-Pin Screw Terminal	
Pin No	Signal
1	Interlock
2	A- Center tap
3	A+
4	A-
5	Earth
6	B+
7	B-
8	B- Center tap
9	Interlock

Limits 4-Pin Screw Terminal	
Pin No	Signal
1	Ground
2	Home
3	Neg
4	Pos

Programmable I/O Pin Outs 50-Pin Screw Terminal			
Pin No	I/O Connector		
1	Input #16	27	Input #7
3	Input #15	29	Input #6
5	Input #14	31	Input #5
7	Input #13	33	Output #4
9	Input #12	35	Output #3
11	Input #11	37	Output #2
13	Input #10	39	Output #1
15	Input #9	41	Input #4
17	Output #8	43	Input #3
19	Output #7	45	Input #2
21	Output #6	47	Input #1
23	Output #5	49	+5VDC
25	Input #8		Even-numbered pins connected to common logic ground.

## ZETA Drives Connection

(ZETA4, ZETA4-240, ZETA8 & ZETA12)

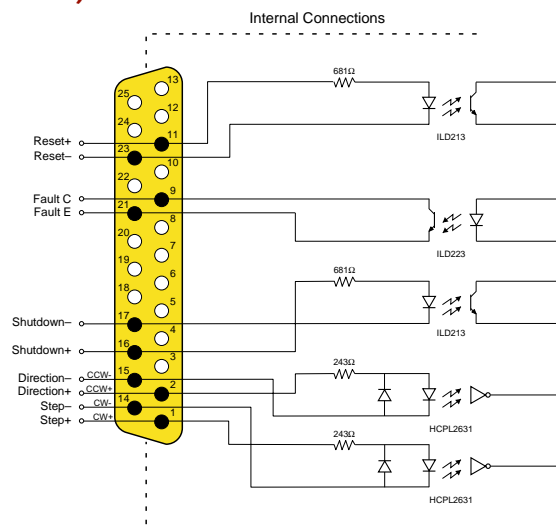

ZETA Series: True Innovation In Microstepping Technology. Call 1-800-358-9070 Today.

Ordering Information			
Drives	<b>Part No.</b>	<b>Description</b>	
	ZETA4	Packaged 4Apk, 170VDC bus microstepping drive	and <b>CE (LVD)</b>
	ZETA4-240	@120VAC: Packaged 4Apk, 170VDC bus microstepping drive @ 240VAC: Packaged 4Apk, 340VDC bus microstepping drive	and <b>CE (EMC &amp; LVD)</b>
	ZETA8	Packaged 8Apk, 170VDC bus microstepping drive	and <b>CE (EMC &amp; LVD)</b>
	ZETA12	Packaged 12Apk, 170VDC bus microstepping drive	and <b>CE (EMC &amp; LVD)</b>
Drive/Controller	ZETA6104	Packaged 4Apk, 170VDC bus microstepping indexer/drive	and <b>CE (LVD)</b>
	ZETA6104-240	@120VAC: Packaged 4Apk, 170VDC bus microstepping indexer/drive @ 240VAC: Packaged 4Apk, 340VDC bus microstepping indexer/drive	and <b>CE (LVD)</b>
	ZETA6108	Packaged 8Apk, 170VDC bus microstepping indexer/drive	and <b>CE (LVD)</b>
	ZETA6112	Packaged 12Apk, 170VDC bus microstepping indexer/drive	and <b>CE (LVD)</b>
Drive/Controller Accessories <b>CE (LVD)</b>	VM24S	24V input/output module	
	VM50	50-pin header-to-screw terminal breakout board	
	RP240	Operator interface	
	RP240-NEMA 4	NEMA 4 rated operator interface	
Drive/Controller Software	DDE6000	DDE server for 6000 Series	
System	C10 (C10H)*	LVD/EMC step-motor cable kit (includes 10-ft cable, gland (360° shield connector), R-clamp, screw, and assembly instructions)	
	ZETA EMC KIT	LVD/EMC Drive Kit (includes the AC power filter and EMC drive/indexer cable)	

\* C10H is a high-power version of the C10 cable kit. IT should be used with motors operating above 10 amps of current (TS33, TS41, TS42, or TS43 in parallel)

To comply with EMC and low-noise (CISPR 22/EN55022 Class B or FCC Class B emissions) standards, the following items are required:

- ZETA4-240, ZETA8, or ZETA12 drive
- CE(LVD) motor for LVD. Compumotor recommends a terminal board (NPS) motor construction for easier EMC installation
- C10 (C10H) motor accessory (LVD/EMC cable kit)
- ZETA EMC KIT

# Motor Ordering Information

## O Series (CE(LVD), UL Pending)

The O Series Size 23 Frame motors with A Winding (75VDC) are designed for use with the OEM750 Series, OEM230/330/530 Series, and the SD Series. The O Series Size 23 Frame motors with B Winding (170VDC) are designed for use with ZETA Series, ZETSA-240 Series (@120VAC), S Series, PD Series.

Series O (Octagonal)	Type S=Standard	Frame Size 2=Size 23	No. of Rotor Stacks H=Half stacks 1=1 stack 2=2 stacks	Winding Type A=75VDC winding (Gray painting motors) B=170VDC winding (Black painted motors)	Shaft S=Single D=Double (Double shaft req'd for all motors with encoders)	Shaft Modification N=Standard smooth F=Flat (.02" depth) (0.5" length)	Motor Construction/ Hookup FLY=Regular construction with flying (8) leads, 12" L10= Regular construction with 10' LVD cable	Encoder Option Blank=No feedback (no dash required) HJ=512 ppr single-ended kit encoder w/12" flying leads (only available on A winding motors) RE=1000 ppr differential kit encoder w/ line driver & 13" braided shield cable (w/ FLY only) RC=1000 ppr differential kit encoder w/ line driver & 10' cable
-------------------------	--------------------	-------------------------	---	---	---	--	---	--

### O Series Part Number Example:

OS2 \_ \_ - \_ \_ \_ \_ - \_ \_  
OS2HA-SNFLY  
OS22B-DNL10-RC

## R Series (CE (EMC)\*, CE(LVD), UL Recognized)

The R Series Size 34 and Size 42 Frame motors are available in a C Winding (340VDC). Motors with the C Winding are recommended for use with the ZETA240 Series (@240VAC).

Series R (Round)	Type S=Standard E=Enhanced (RE 42 only)	Frame Size 3=Size 34 4=Size 42	No. of Rotor Stacks 1=1 stack (34 Frame Only) 2=2 stacks 3=3 stacks	Winding Type C=340VDC winding (Yellow painted motors)	Shaft S=Single D=Double (Double shaft req'd for all motors w/ encoders)	Shaft Modification N=None (34 Frame only) K=Straight Key (Standard on 42 Frame) F=Flat (34 Frame only, 0.02" depth, 0.5" length)	Motor Construction/ Hookup NPS=End bell/terminal board via 1/2" NPS Pipe thread P10=CE (LVD)/UL, 10' cable option for NPS construction, wired @ motor in Parallel. S10=CE (LVD)/UL, 10' cable option for NPS construction, wired @ motor in Series.	Encoder Option Blank=No feedback (No Dash Required) EC=1000 ppr differential encoder with line driver and 10' cable (-E Series)
---------------------	---	--------------------------------------	--	--	---	---	--	---

### R Series Part Number Example:

R \_ \_ \_ - \_ \_ \_ \_ - \_ \_  
RS32-SNS10  
RE42C-SKNPS  
RS42-DKS10-EC

## T Series (CE (EMC)\*, CE (LVD), UL Recognized)

The T Series Size 34 and Size 42 Frame motors are available in a B Winding (170VDC). These motors are designed for use with the ZETA Series, ZETA-240 (@120VAC), PD Series, S Series.

Series T (Torque)	Type S=Standard	Frame Size 3=Size 34 4=Size 42	No. of Rotor Stacks 1=1 stack 2=2 stacks 3=3 stacks	Winding Type B=170VDC winding (Black painted motors)	Shaft S=Single D=Double (Double shaft req'd for all motors w/ encoders)	Shaft Modification K=Straight Key (Standard on all T Series Motors)	Motor Construction/ Hookup NPS=End bell/terminal board via 1/2" NPS Pipe thread, no cable S10=CE (LVD)/UL, 10' cable option for NPS construction, wired @ motor in Series P10=CE (LVD)/UL, 10' cable option for NPS construction, wired @ motor in Parallel.	Encoder Option Blank=No feedback (No Dash Required) EC=1000 ppr differential encoder with line driver and 10-ft cable (-E Series)
----------------------	--------------------	--------------------------------------	--	---	---	--	---	---

### T Series Part Number Example:

TS \_ \_ B - \_ K \_ \_ \_ - \_ \_  
TS31B-SKNPS  
TS43B-DKS10

\* For CE(EMC) compliance, refer to the ZETA Installation Guide

ZETA Series: True Innovation In Microstepping Technology. Call 1-800-358-9070 Today.

# Motor Ordering Information, continued

## E Series (also known as ZETA Series)

The E Series Size 23 and Size 34 Frame motors are available in a B Winding (170VDC). These motors are designed for use with Gemini GT-L5, Gemini GT-L8, the ZETA Series, ZETA4-240 (@120VAC), PD Series, S Series.

Series E (Extra Smooth)	Type S=Standard	Frame Size 2=Size 23 (2.5") 3=Size 34 (3.38")	No. of Rotor Stacks 1= 1 stack 2= 2 stacks 3= 3 stacks	Winding Type B=170VDC winding (Black painted motors)	Shaft S=Single D=Double Double shaft req d for all motors w/encoders	Shaft Modification N=None (Standard) F=Flat (.02" depth) (0.5" length) K=Straight Key (34 Frame Only)	Motor Construction/ Hookup R10=Regular hookup w/ 10' Flying Leads	Encoder Option Blank=No feedback (no dash required) EC=1000 ppr differential line encoder w/ 10' cable
-------------------------------	--------------------	---	---	--	---	--	--	--

### E Series Part Number Example

ES \_\_ B - \_ K \_ - - - -  
 ES31B-SKNPS  
 ES43B-DKS10

## V Series (UL Recognized)

The V Series Size 17, Size 23 and Size 34 Frame motors are available in a B Winding (170VDC). These motors are designed for use with the E-AC drive, the Gemini GT-L5, the Gemini GT-L8, the ZETA Series, the ZETA4-240 (@120VAC), the PD Series and the S Series.

Series V	Type S=Standard	Frame Size 1=Size 17 2=Size 23 3=Size 34	No. of Rotor Stacks 1=1 stack 2=2 stacks 3=3 stacks	Winding Type B=170VDC winding (black painted motors)	Shaft S=Single D=Double	Shaft Modification N=Standard (smooth) F=Flat (.02" depth) (.5" length)	Motor Construction/ Hookup FLY - 12" flying leads RIO - 10' cable to flying leads
-------------	--------------------	---	--	--	-------------------------------	---	---

### V Series Part Number Example

VS \_\_ B - \_ K \_ - - - -  
 VS13B-DFRIO

Parker核心代理商



北京润诚时代科技有限公司

自动化事业部

地址：北京市朝阳区汤立路218号C座968室

邮编：100012

电话：010-84450370

传真：010-84450371

网址：www.runcheng.net